

From: [Montoya, Michelle](#)
To: ["Adam Sharron"](#); ["Art Deicke"](#); ["Carole Quandt"](#); [Carter, Charles](#); ["Kevins Sea "](#); [Lyle, Amy](#); ["Mark Neely"](#); [Montoya, Michelle](#); ["Steve Rabinowitsh"](#)
Cc: [Sheikhali, Monet](#); [Hopwood, Kimberly](#)
Subject: Late Correspondence - Item 5.1 - Hyatt Regency Sonoma Wine Country Fence and Lighting
Date: Tuesday, January 25, 2022 11:58:00 AM
Attachments: [Santa Rosa Creek Design Guidelines.pdf](#)

-Please do not reply to all-

Chair Rabinowitsh and members of the Waterways Advisory Committee,

Staff has provided an additional document for the committee to review related to the Creek Master Plan. Please see attached document. This document will also be added as Late Correspondence to the legislative file.

Thank you,

Michelle Montoya | Administrative Secretary

Planning & Economic Development | 100 Santa Rosa Avenue, Room 3 | Santa Rosa, CA 95404
Tel. (707) 543-4645 | mmontoya@srcity.org (Currently Working Remotely)



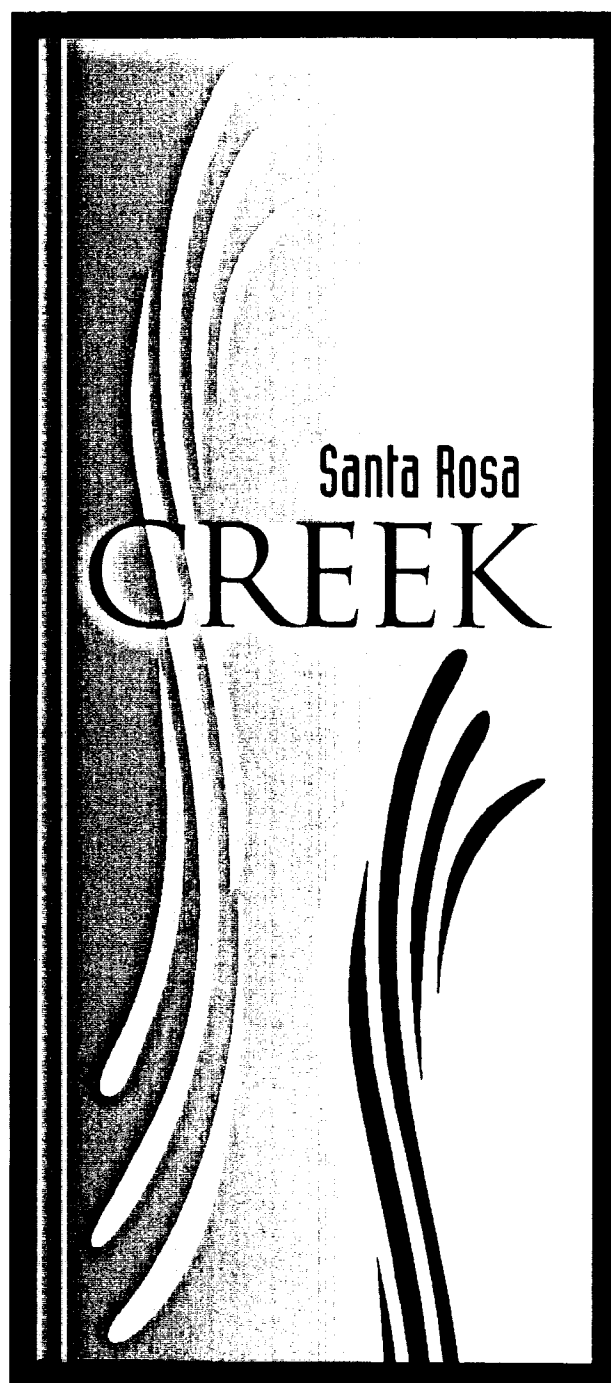

CITY OF SANTA ROSA

SANTA ROSA CREEK
DESIGN GUIDELINES

OCTOBER, 1997

SANTA ROSA CREEK DESIGN MANUAL

CITY COUNCIL

Sharon Wright, Mayor
Janet Condron, Vice-Mayor
David F. Berto
Noreen M. Evans
Mike F. Martini
Mike Runyan
Pat Wiggins

PLANNING COMMISSION

Michael Menendez, Chair
Vinny Denietolis, Vice-Chair
Bob Blanchard
Richard Carlile
Lee Cummings
Frances Dias
Barbara Lynch

DESIGN REVIEW BOARD

William Benjamin, Chair
Renee Felciano, Vice Chair
Scott P. Bartley
Jack A. Macy
Donald Tomasi

CITY MANAGER

Kenneth R. Blackman

DEPARTMENT OF COMMUNITY DEVELOPMENT

Wayne G. Goldberg, Director
Charles J. Regalia, Deputy Director - Planning
J. Mike Sheppard, Senior Planner

DESIGN TEAM

Dianne Thompson - Project Manager/Designer
Department of Administrative Services

Dave Kull - Project Manager/Designer
Recreation and Parks Department

Mark W. Bowers - Landscape Architect
Resource Design, Santa Rosa, CA

Adopted by City Council - Resolution Number

Table of Contents

I.	SANTA ROSA CREEK DESIGN GUIDELINES OVERVIEW	4
A.	Introduction	4
B.	Regional Map	4
C.	Waterway Map	5
D.	Site Planning and Zoning	5
II.	DESIGN GUIDELINES	6
A.	Design Guidelines Approach	7
B.	How to Use This Manual	7
1.	Site Planning	11
	• Commercial	
	• Residential	
2.	Grading	18
	• Natural Reaches	
	• Rural Reaches	
	• Urban Reaches	
3.	Creek Crossings	19
	• Vehicular	
	• Multi-use Paths	
	• Bridge under-crossing	
	• Low water crossings	
4.	Architecture	23
	• Commercial	
	• Residential	
5.	Site Furnishings	24
6.	Construction Materials	25
	• Natural Reaches	
	• Rural Reaches	
	• Urban Reaches	
	• Historic Railroad Square	
	• Commercial Core	
7.	Pathways	27
	• Multi-use Soft Paths	
	• Multi-use Hard Paths	
	• Natural Soft Path - Pedestrian only	
	• On-street connectors	
	• Cantilevered boardwalks	
8.	Logo	30
9.	Creek Signage	31
	• Entry Point Sign	
	• Informational Sign	
	• Directional Sign	
10.	Trailheads and Trailside Parks	32
11.	Lighting	34
12.	Landscaping and Plant Materials	35
13.	Fencing	36
14.	Irrigation	40

III. SANTA ROSA CITY STANDARDS

Standard	110	Entry Signs
Standard	111A	Informational Signs
Standard	111B	Directional Signs
Standard	112A	Street & Multi-Use Pathway Lights
Standard	112B	Walkway Lights
Standard	112C	Wall Lights
Standard	112D	Wall Lights
Standard	113	Benches
Standard	114	Tree Grates
Standard	115	Bike Racks
Standard	116	Drinking Fountain
Standard	117	Trash Recepticals
Standard	118	Logo

Chapter I

Santa Rosa Creek Design Guidelines Overview

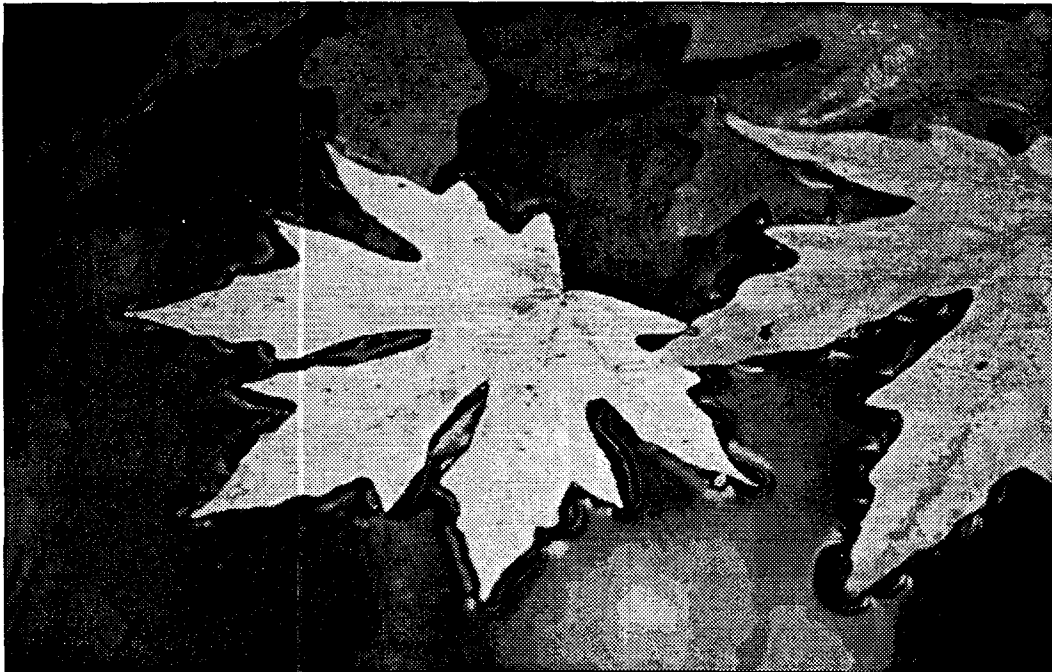

I. SANTA ROSA CREEK DESIGN GUIDELINES OVERVIEW

A. INTRODUCTION

Santa Rosa Creek is the major waterway of the City of Santa Rosa. Early in the City's history, the creek provided food and shelter for an abundance of wildlife and at the same time provided settlers with a good source of food and water. The creek also contributed to the City's considerable natural beauty.

Over time, this natural beauty was increasingly threatened by development as urbanization pushed closer to the creek banks. By the early 1950's Santa Rosa had grown to a point where the creek's 56,000 acre natural drainage basin had been highly altered. These changes increased runoff and flooding became a concern to residents and business owners alike.

By the mid-1960's, Santa Rosa Creek had been reconfigured through most of the urban core. About this same time many Santa Rosans were becoming aware that a major amenity was being lost. In 1988, planning for restoration of the creek took a major step forward when the Citizens for Santa Rosa Creek Committee was formed. The goal of the group was to plan total restoration of the altered portions of the creek and to protect the unaltered portions from further degradation. The results of the Committees' work along with the city and county staff was the Santa Rosa Creek Master Plan.

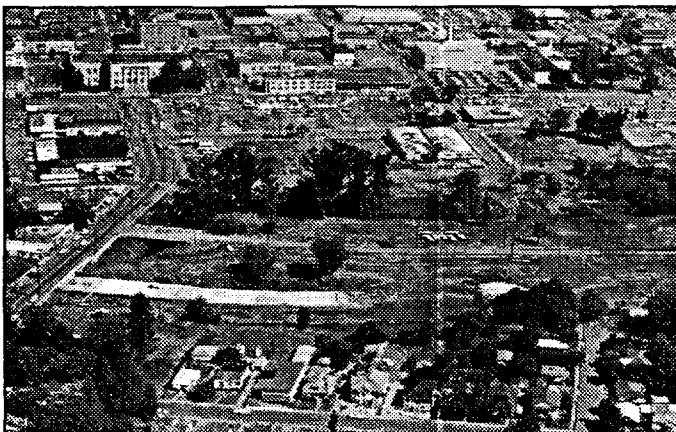
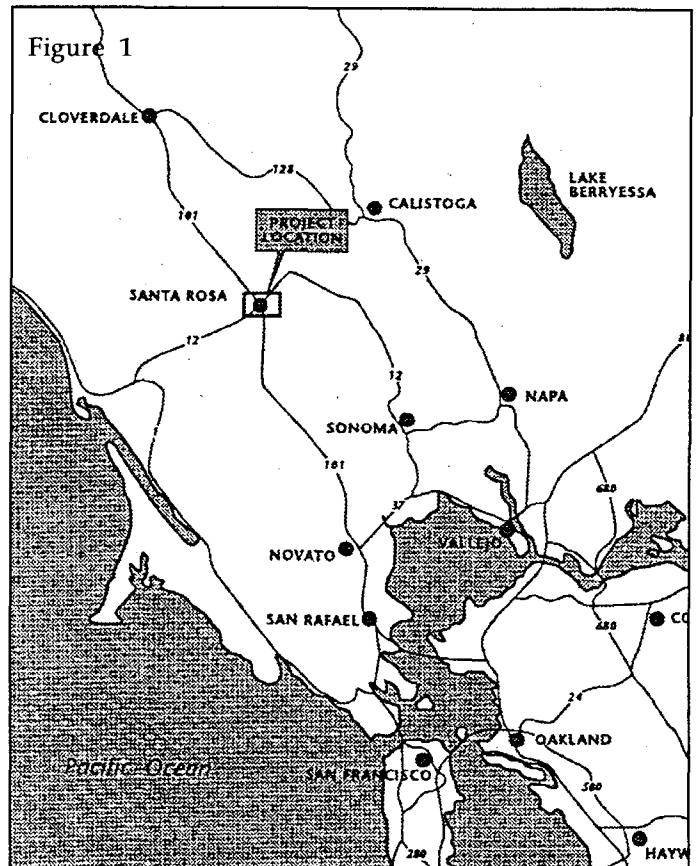

Photo 1
Construction of a concrete box culvert in Santa Rosa Creek for future City Hall site.

The next step in restoring the creek was to secure funding sources. The Santa Rosa Creek Master Plan estimated that \$55.5 million was required for restoration of the entire creek. The Santa Rosa City Council has authorized \$5.6 million in the City's 1995-1996 Capitol Improvement Program for the Phase I restoration project. Council further designated \$3.5 million from the Prince family bequest to the City towards Phase I construction.

B. REGIONAL MAP



C. WATERWAYS MAP

Figure 2

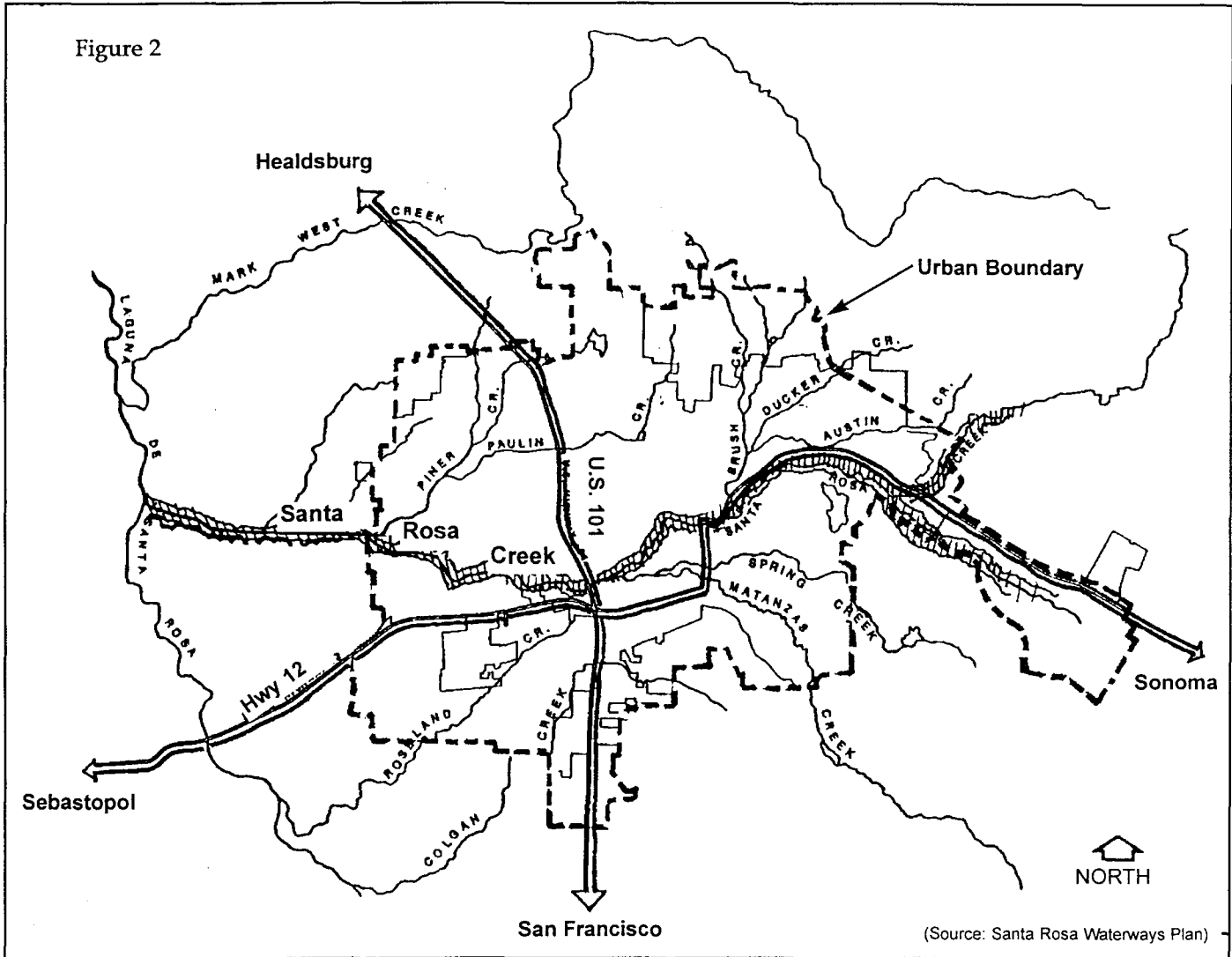

D. PLANNING AND ZONING

Design Objectives:

To promote & maintain diverse types of compatible land uses along the Creek Corridor that preserve & enhance the creeks natural environment while promoting public use for people of all abilities.

Refer to the City of Santa Rosa's General Plan, July 23, 1996, and the Zoning Ordinance, Revised July 1, 1995.



Chapter II

Design Guidelines

II DESIGN GUIDELINES

A. Design Guidelines Approach

The approach used in developing the Design Guidelines has been to emphasize the creek's natural attributes while providing amenities necessary to make the creek accessible and inviting. A primary goal in this process is to create a healthy environment for native vegetation and wildlife. Along with restoration of the creek itself, the creek banks will be developed with multi-purpose paths for various recreational uses, a natural backdrop for adjacent residential and commercial uses, and educational opportunities for the community.

In order to create a consistent natural identity for the creek from its rural headwaters through the downtown corridor and out into the agricultural reaches in the Laguna de Santa Rosa, a palette of materials has been selected for incorporation into the design elements. Materials were chosen for their natural character, adaptability to various applications, aesthetics, and economic considerations.



Photo 2 Interstate Hwy 101 crossing Santa Rosa Creek

Inherent in these Design Guidelines is a recognition that the creek traverses several distinctly different settings, from rural wooded reaches, through residential, urban, historic, suburban and agricultural zones. Therefore, a design theme has been established for consistency throughout the length of the creek while permitting adaptability to the unique characteristics of each location. Design considerations include the ability of selected materials to adapt to various conditions, the

reinforcement of different site characteristics through unique styles of architectural detailing and the ability to withstand the effects of hand use and/or vandalism.

Stone masonry, "weathered" wood, and black powder-coated steel were selected for theme elements along the entire length of the creek. The Design Standards included in these Design Guidelines incorporate one or more of these materials into each element.

Some sections of the creek to undergo restoration will be funded, designed and constructed by the City. Other portions will be funded and built by developers, contractors, homeowners, and other private parties. Some improvements will be completed as part of major public works projects, others by adjacent land owners and still others by City maintenance workers over long periods of time. The essential component to the overall success of the creek restoration process will be to follow the standards, maintaining consistency of design, intent and quality throughout the entire creek corridor.

If development occurs as envisioned in these Design Guidelines, the result will be a pleasant, sustainable, environmentally sound, pedestrian-scaled creek corridor that stimulates a renewed interest in protecting the creek for the benefit and enjoyment of all future generations.

This design manual is composed of special design criteria and guidelines for development and restoration along the Santa Rosa Creek Riparian Corridor. These guidelines should be used as a supplement to the City's General Plan, Zoning ordinance, Design Guideline Standards, Santa Rosa Waterways Plan and the Santa Rosa Creek Master Plan.

B. HOW TO USE THIS MANUAL

This manual breaks down various reaches of the creek, as described in the Santa Rosa Creek Master Plan, into three categories that reflect the predominate character and adjacent land uses found along the creek corridor:

Urban Reaches

Rural Reaches

Natural Reaches

(See figure 3, Reach Index Map, pages 9 & 10)

In all three categories, the intent of this manual is the following:

- To develop basic standards and guidelines that promote the input and creativity of different consultants (Landscape architects, designers, architects, planners, artist and engineers), businesses, community groups and residents to develop a cohesive final end product and community treasure.
- Improve the aesthetic value of existing and adjacent land uses.
- Guide new development to restore the natural creek environment and incorporate the creek into the project site as an amenity.
- Provide a common goal for development, so that as construction occurs in phases it will serve to unify and give identity to the creek environment. The result will be development that is a cohesive asset to the community.
- Promote the unique character and 'sense of place' of various reaches of the creek and their historical significance, while maintaining continuity of design.
- Maintain continuity and simplicity with construction materials, forms and site furnishings and encourage creative design solutions for development along the creek.

Urban Reaches

This designation refers to areas along the creek corridor (Reaches C,D and E) that are adjacent to the downtown area, or in areas where future commercial development offers the opportunity to integrate commercial uses with creek restoration. One example is the Grace Brothers Site at Third Street and Wilson, the future Hotel/Conference Center location.

Rural Reaches

This designation refers to areas along the creek corridor that are adjacent to rural and agricultural land uses: Reaches F and G. These reaches and areas extending to the Laguna De Santa Rosa, offer the opportunity to restore and enhance previously engineered waterways into self-sustaining natural environments.

Typical uses in this area would be multi-purpose trailheads, recreational and wildlife facilities, and wetland restoration and enhancement. Visitors could access various points for viewing wetland wildlife, bird watching at the delta pond (which stores recycled water for irrigation) and exploring wetlands.

These types of concentrated development facilities would enhance the educational aspects of the creek and be compatible with adjacent farming and agricultural land uses.

Natural Reaches

This designation refers to preservation reaches of the creek.; Reaches A-East, A-West, and Reach B . Development in these areas would be primarily limited to ecological enhancements of the natural creek environment. Enhancements would include removal of introduced landscape plants (Ivy, Himalaya Berry) and replacement with native species, pool restoration (cold water fisheries) and ecologically sensitive erosion control (wattling).

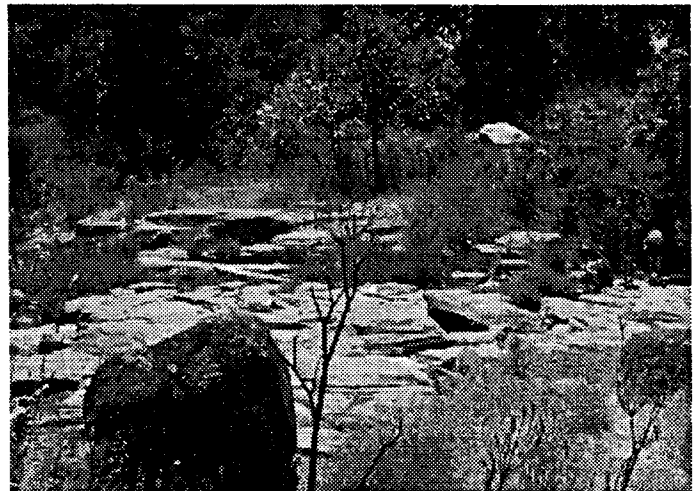
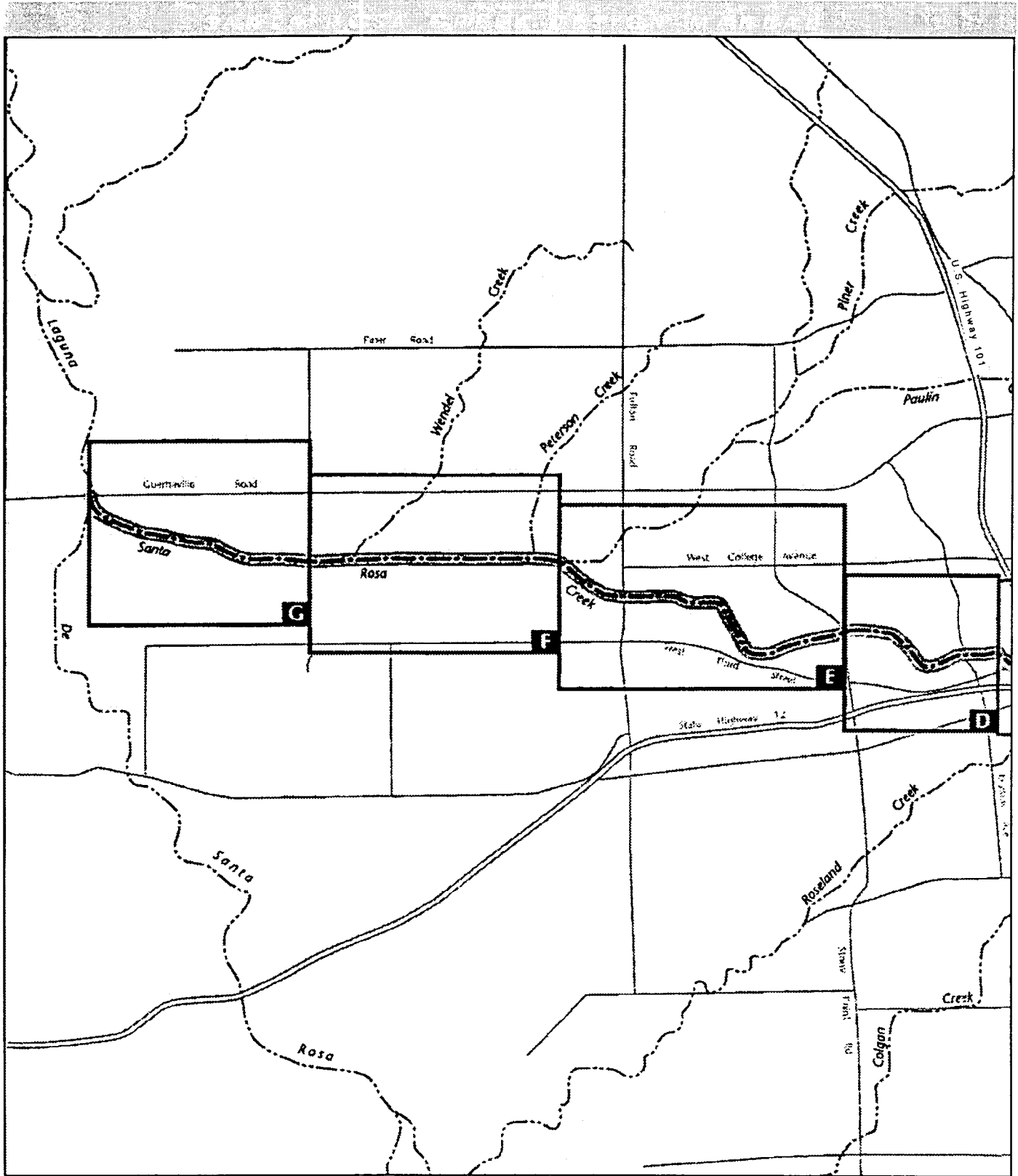
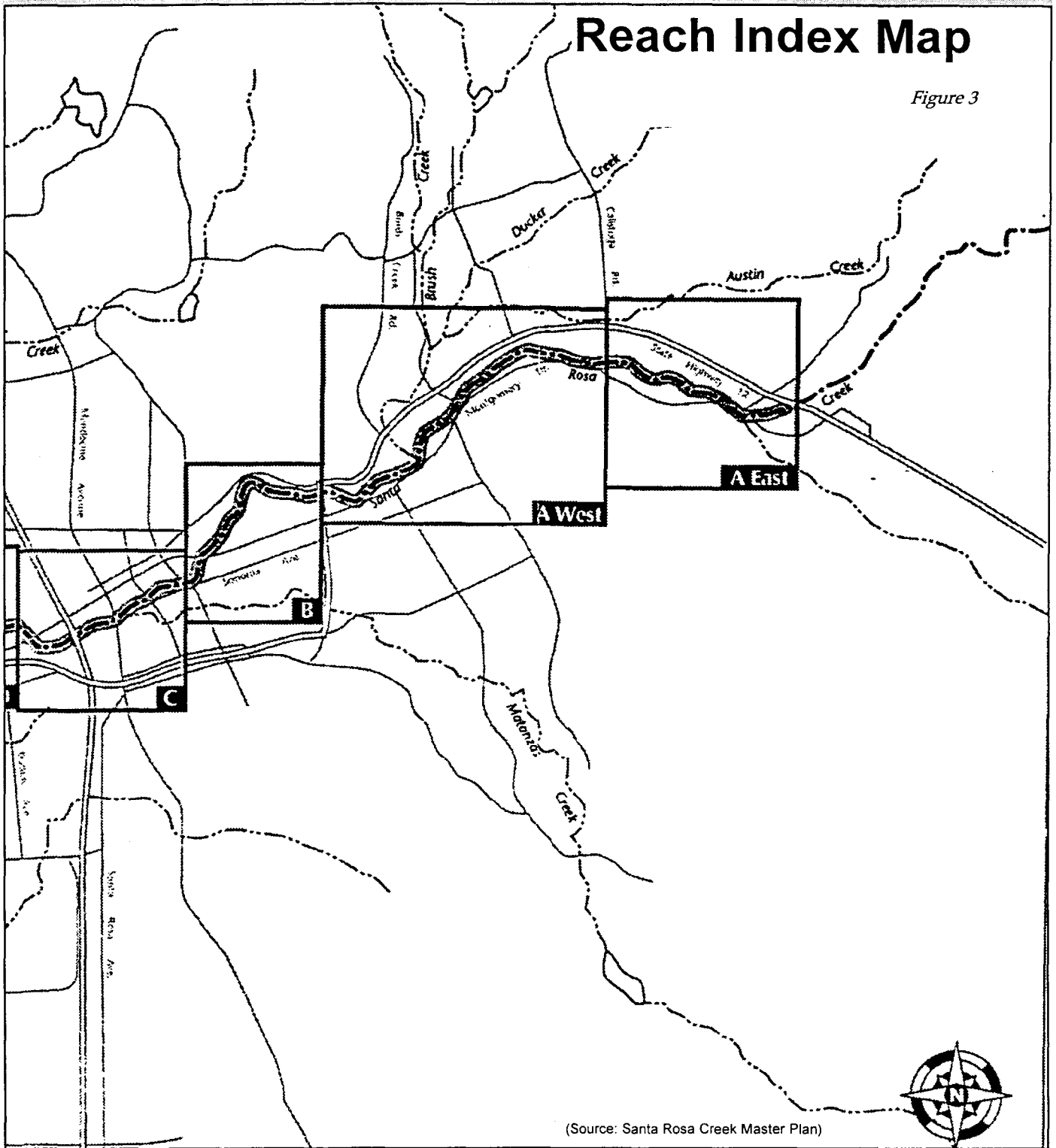

Photo 3
Flat Rock Park, summer 1996



Reach Index Map

Figure 3



(Source: Santa Rosa Creek Master Plan)

There are two trailside parks that are planned for Reach A-West: Mission 2000, east of Mission Blvd., and Flat Rock Park at the confluence of Santa Rosa Creek and Brush Creek. Flat Rock Park is the location where it has been suggested that, Rosa, a Native American girl, was baptized, thus our City name Santa Rosa.

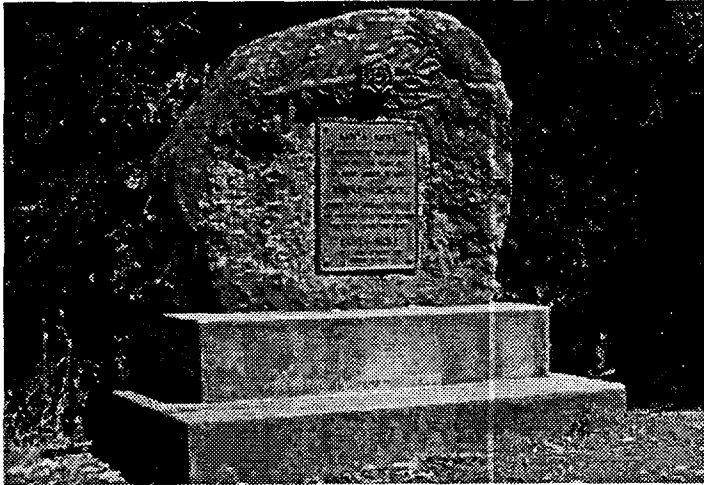

Photo 4

A commemorative landmark to the Native American Indians located at the intersection of Brush Creek & Santa Rosa Creek.

The creek also passes the Carrillo Adobe and Native American site. This is an historically significant site with great archeological and cultural value. It is recommended that this area be provided with park-type amenities (benches, signs, trails, etc.) that preserve and enhance the historical and archeological character of the site.

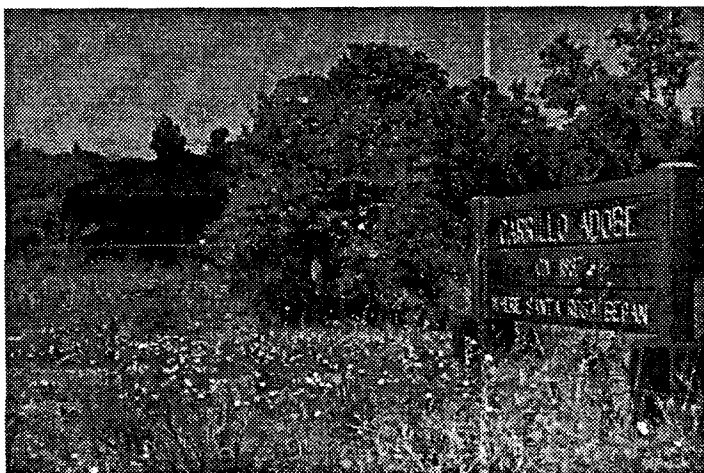

Photo 5

Carrillo Adobe now housed by a structure to protect the deteriorating clay brick from the weather.

1. SITE PLANNING

Design Objective: To encourage creek compatible development and rehabilitation of existing land uses along the street and the adjacent creek corridor, promoting public use of the creek and preserving and/or enhancing the natural creek environment.

Creek Interface

1. Development of plans along the creek corridor shall be designed to preserve and incorporate the creek as an asset into the development.

Commercial Site Layout and Setbacks

(See Figure 4 & 5, pages 12 & 13)

1. Commercial development must utilize a site plan that orients development, views and outdoor spaces to the creek corridor.
2. Buildings shall be laid out to maintain and promote views to the creek from adjacent properties.
3. Outdoor spaces shall be designed with landscaped pedestrian links and bike paths to creek trails.
4. Provide site furnishings such as bike racks, signage, benches, public art, and lighting to accentuate the trail, the business and public access.
5. Consolidate trash, recyclables, utility and loading areas on the site and incorporate into architecture. Avoid visibility from the creek of such accessory structures.
6. Provide a buffer and screen between conflicting adjacent land uses, using architectural elements or landscape materials.

Commercial Parking and Vehicular Circulation

1. With the predominate views being the street frontage and views from the creek corridor, parking should be consolidated to the sides of the parcel and screened from off-site views.

Small Lot Commercial Planning

Figure 4

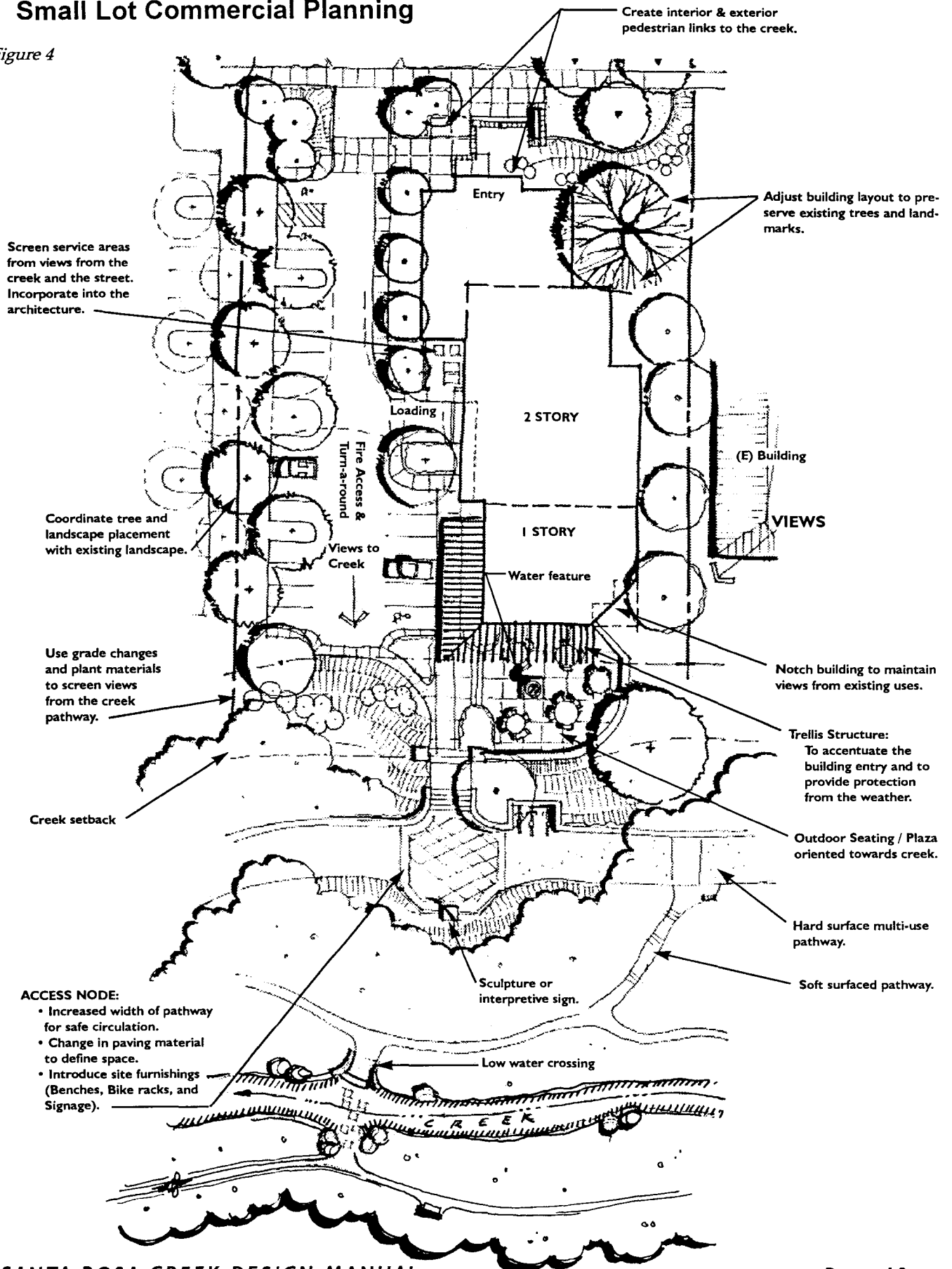

Large Lot Commercial Site Planning

Figure 5

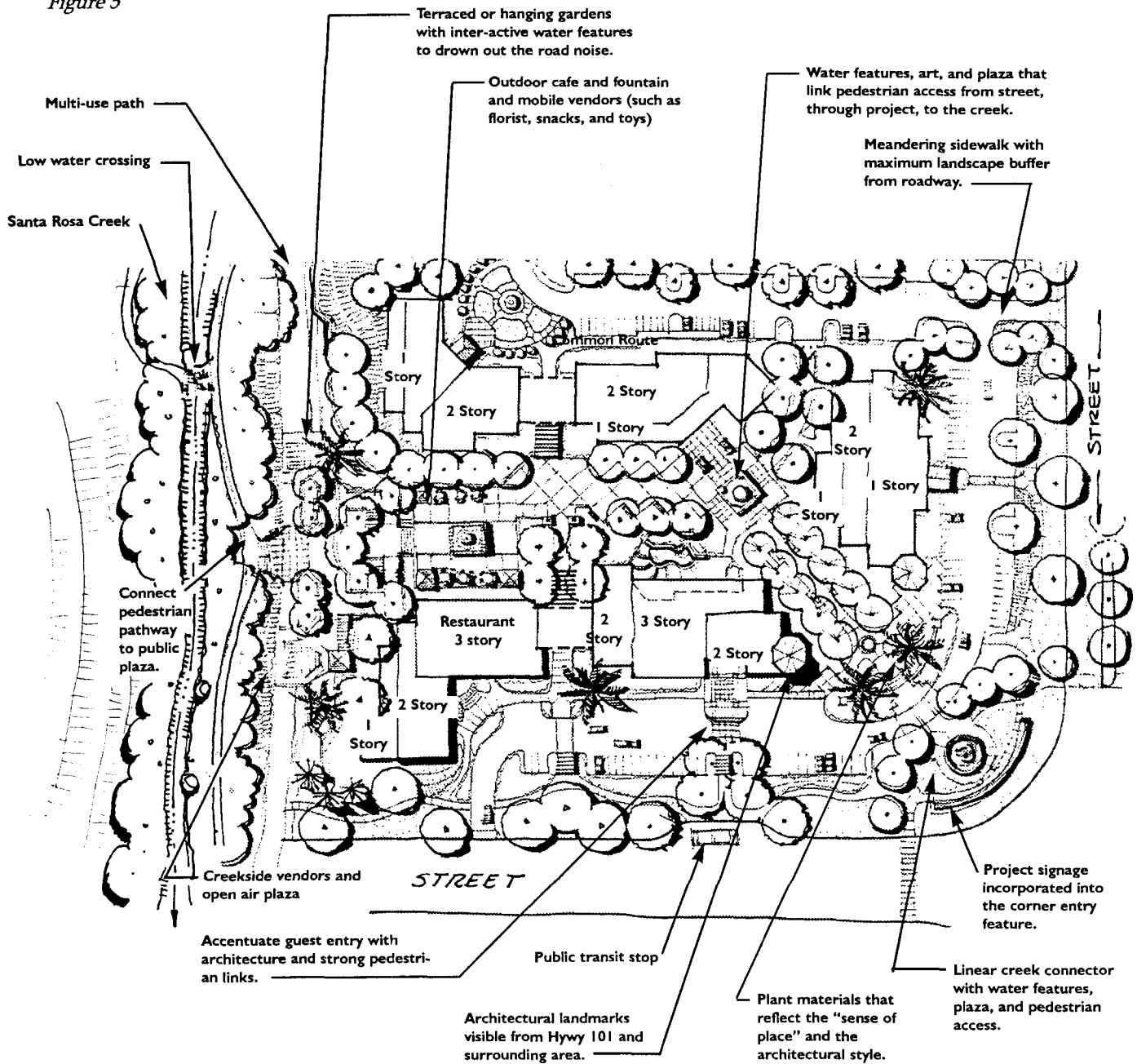

- Promote the opportunity to consolidate side parking areas between multiple parcels through the use of easements. This would free up more area for parking, landscaping, and outdoor spaces. Common entry drives for this type of parking would also limit the amount of driveway ingress and egress.
- Avoid parking conflicts by providing designated employee parking areas.

Commercial Pedestrian Circulation

- Develop strong pedestrian links to commercial entrances from parking areas and creek trails for people of all abilities. Weatherproof awnings and canopies are encouraged for these links.



Photo 6
Waterproof covered walkway, outdoor seating, and blade signage are integrated into architecture and promote a pedestrian-oriented development.

- Use architectural features, plantings, and special paving materials to aid in defining entrances.
- Enhance pedestrian activity along the creek and at business entry points by widening trail width and providing additional site furnishings or extension of building architecture (trellis, waterproof awnings, etc.).
- Use canopy trees to shade outdoor spaces and paths of travel. In hardscaped areas use 4' square

minimum tree wells with grates or granite square cobbles with root aeration tubes and irrigation systems to promote healthy growth and longevity.

Residential Site Layout and Setbacks

- Refer to Chapter 20-05, Article 3.1 of the zoning code for creekside setback requirements.
- The layout of the streets must be oriented to the creek (examples shown in figures 6, 7, 8, & 9).
- Site and street design shall orient buildings toward the creek or toward paths, entrances, or open spaces that lead to the creek.
- Integrate natural site amenities such as trees, rock outcroppings, and unique views into the site design.
- Limit grading adjacent to the creek corridor to minimize loss of riparian habitat or vegetation and soil erosion.
- Encourage natural surveillance and security by providing visibility from buildings to problem areas along the creek. Locate common areas along the waterway where they can be viewed by residents.
- Promote rear yard open wire fencing with landscaping to maintain desired views to creek. Screen undesirable views with solid fencing and landscaping.

Residential Parking and Vehicular Circulation

- Orient streets to preserve creek views and create access to waterway for as many residents as possible.
- Use streets as a buffer between private property and public access. Encourage off-street parking in these areas. Where on-street parking is necessary, consolidate parking to areas that are not visible from the creek.

- Other examples of street layout patterns that can achieve this objective are from the City of Santa Rosa Waterways Plan, as follows:

Parallel or Waterway-Frontage Street:

The waterway or parallel-frontage street is the preferred approach for placing streets along waterways. The placement of the street and the orientation of the buildings protect privacy by providing clear transitions between public and private space and offer a high degree of surveillance. A hard curb prevents vehicle encroachment and tailgate dumping. (See Photo 7, below and Fig. 6 page 16)

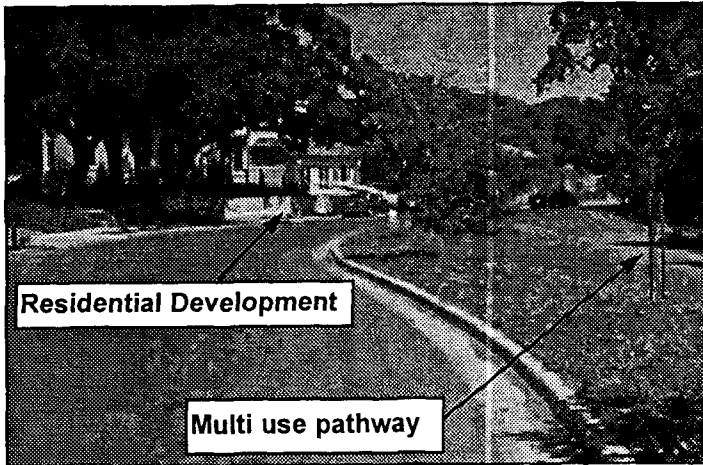

Photo 7
Hampton Woods subdivision is a recent example of street planning using the parallel frontage street.

Radial Design:

Coordinated with parks and other common space, this approach promotes views of specific neighborhood entrances to the waterway area. This design concentrates access in areas of high surveillance, and identifies the neighborhood with key natural features visible from neighborhood avenues.

(see Figure 7, page 16)

Alternating Loop:

This design minimizes exposure of backyards to public spaces along the waterway. Access is available along street frontage, with good surveillance of sections of the waterway. Pedestrian corridors between

residences and the waterway can be established in neighborhood linear parks, providing view corridors.

(see Figure 8, page 17)

Extended Cul-de-sacs: This approach uses common space as a buffer to side and back yards, and provides clear surveillance of the point of entry. Cul-de-sacs may be desirable when natural features or channel characteristics prevent the construction of a street parallel to the waterway. They provide linkage and access to creek pathways.

(see Figure 9, page 17)

Residential Pedestrian Circulation

- Orient development to provide primary all weather access points/paths to the creek that preserve and emphasize the natural site amenities, while creating passive recreational areas.
- Provide secondary access points that work with the development of circulation patterns and decrease distances required to walk to access creek corridor and improve neighborhood surveillance.
- Provide pedestrian amenities, such as shade structures, benches, drinking fountains, trash receptacles and landscaping that accentuate entry points.



Photo 8
Promote road widths that are proportional to the traffic volumes. Create a stronger visual connection to the creek with appropriate site furnishings.

Parallel or Waterway Frontage Street

Figure 6

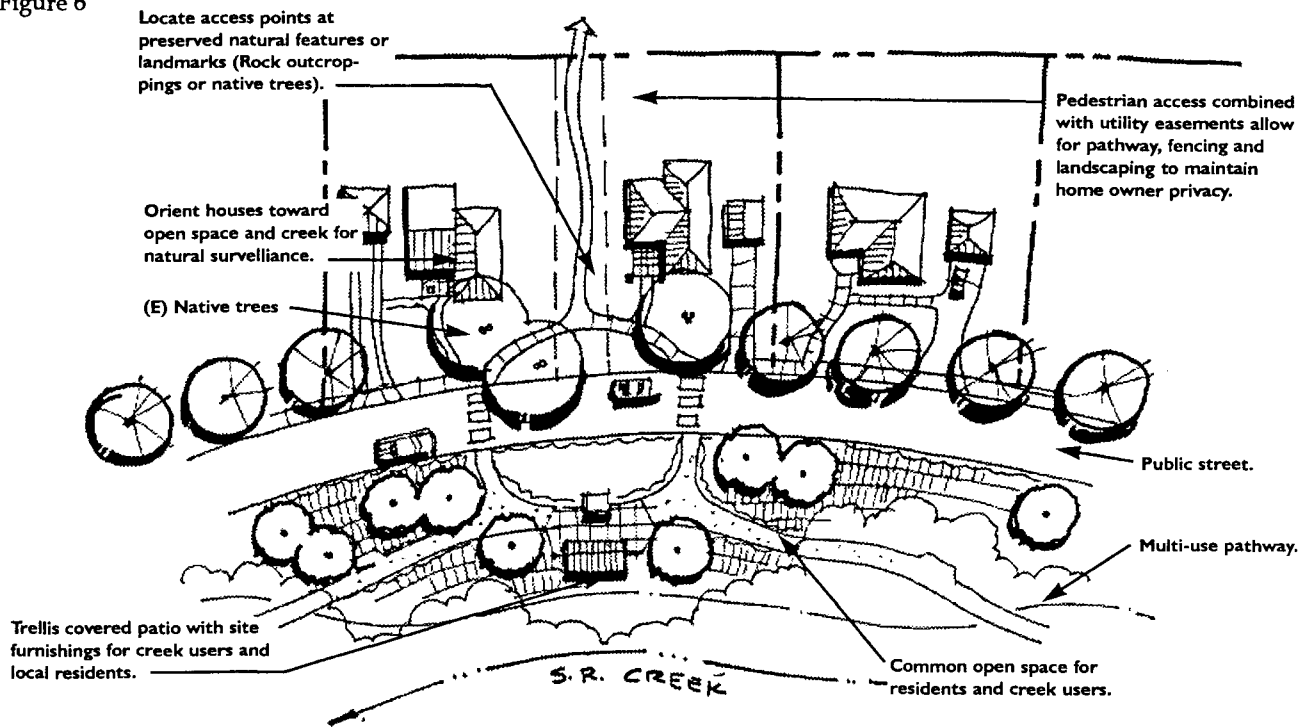

Radial Street Design

Figure 7

A pocket park, designed to preserve natural site amenities (trees, rock outcroppings, or areas of historical significance). These parks can also identify the neighborhood and promote a sense of pride.

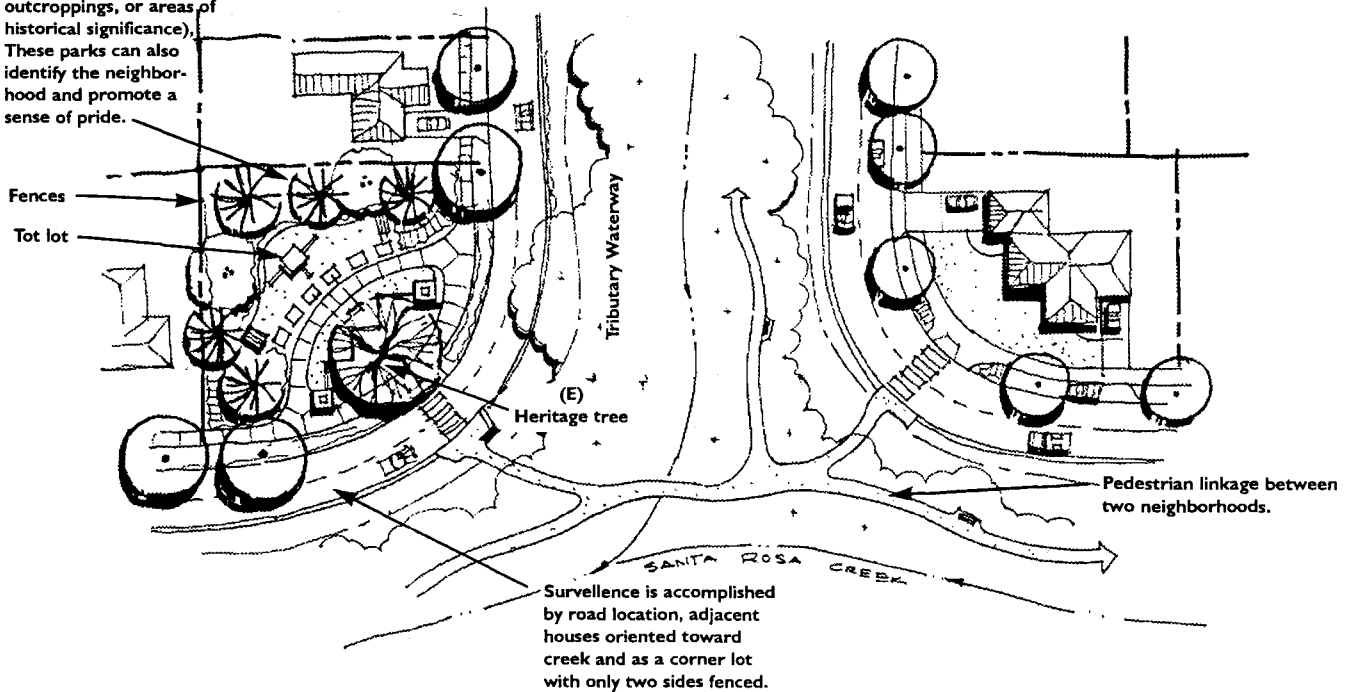

Alternate Loop Design

Figure 8

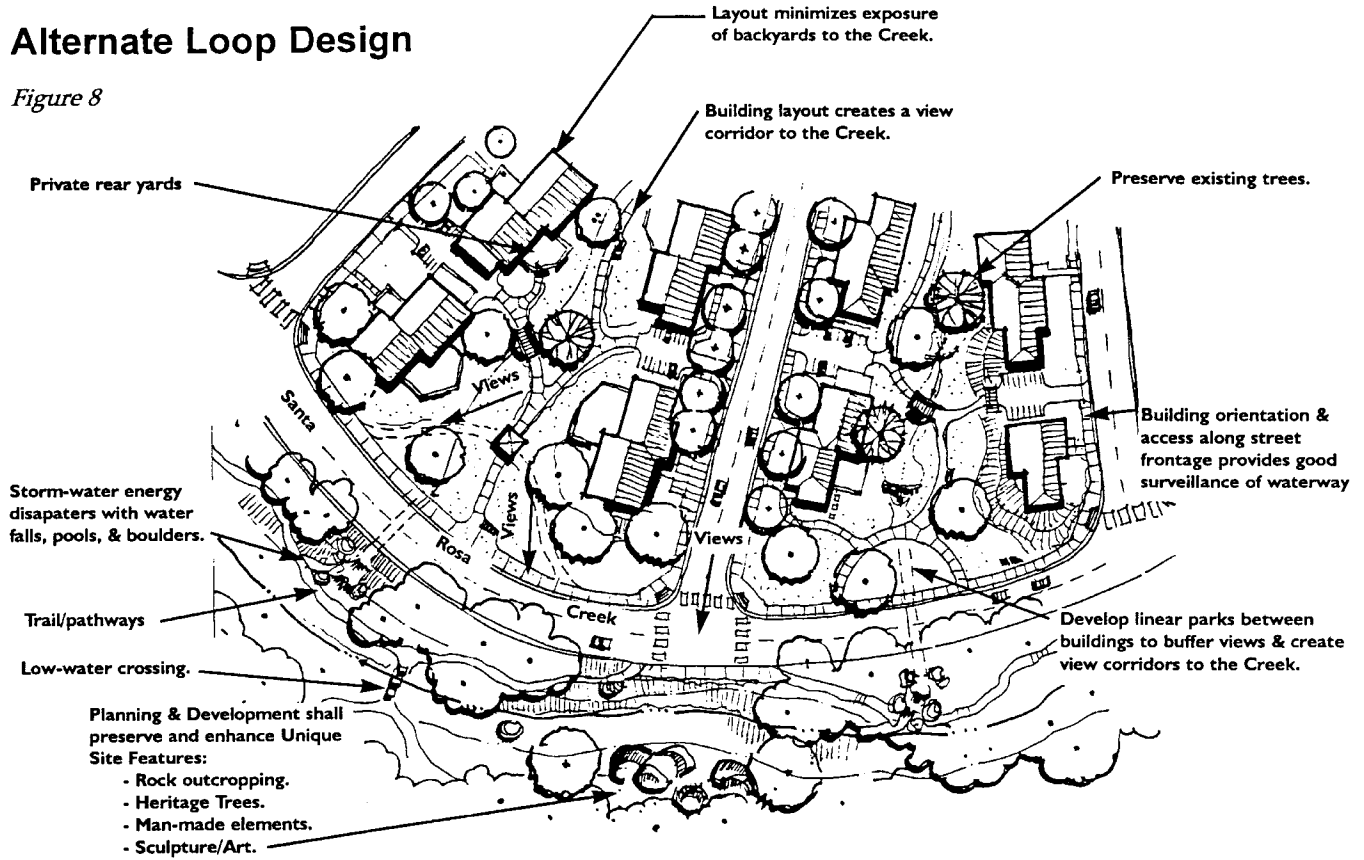

Extended Cul-de-Sac Street Design

Figure 9

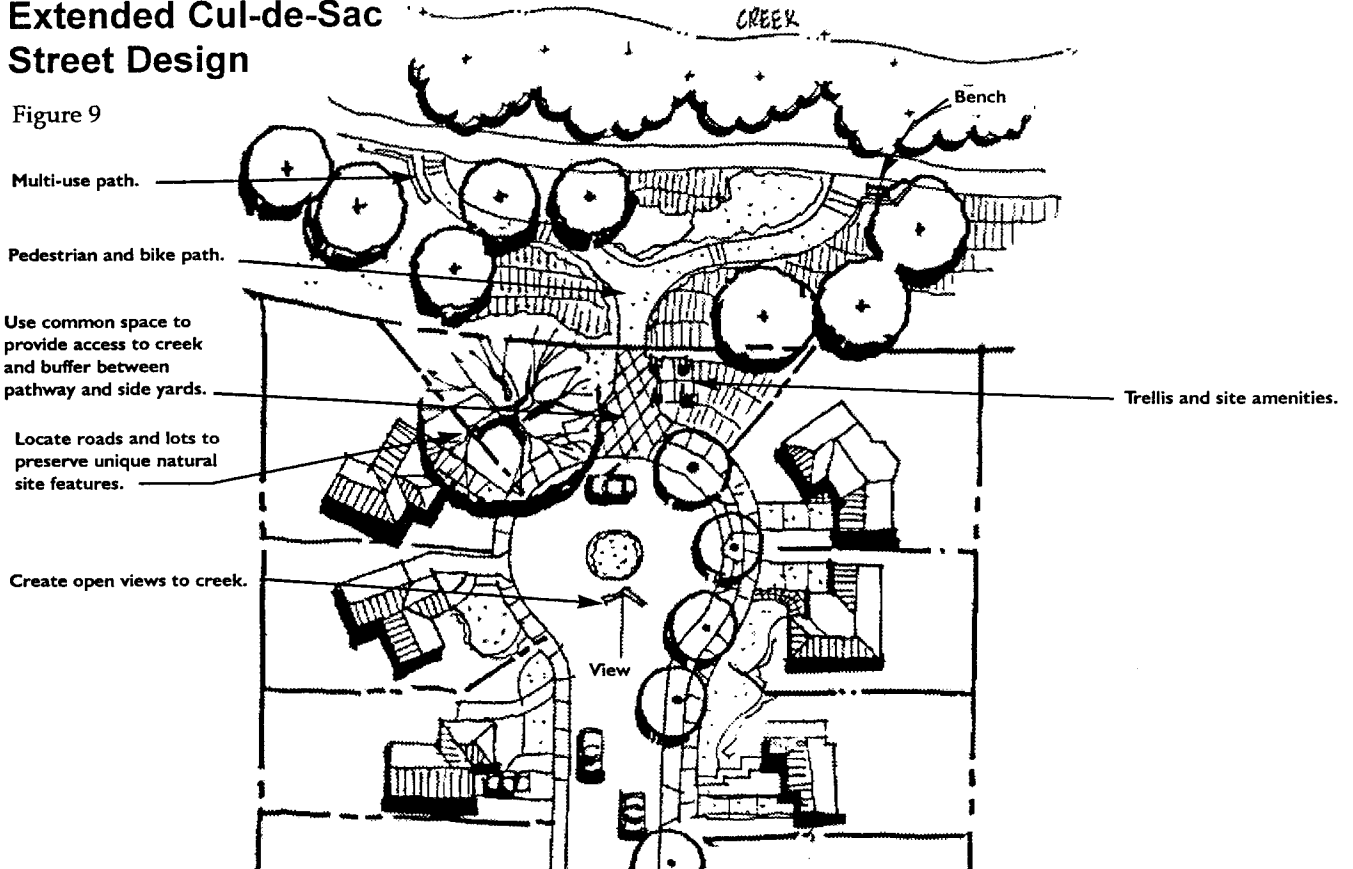

2. GRADING

Design Objective:

In accordance with Section 2 of the Santa Rosa Waterways Plan, provide minimal grading as required in creek channel, on banks, and top of slopes, while protecting and restoring the native riparian environment and natural site conditions.

General Recommendations

1. To the greatest extent possible grade to restore natural stream processes.
2. Increase hydraulic capacity of creek where necessary.
3. Prepare re-vegetation and erosion control plans for all graded and disturbed areas to prevent sedimentation of low flow channel.
4. Grading operations and construction in all creek reaches shall be phased to avoid construction during the wet weather season.
5. Protect and preserve all healthy native trees as per tree ordinance. When grading for hydraulic capacity requires removal, mitigate all tree removals with replacement of appropriate native species. Refer to City tree ordinance. (Chapter 17-24)
6. Create a vegetation and tree protection plan to preserve the greatest amounts of native vegetation while meeting Creek Channel Design criteria.

Natural Reaches

1. Mechanical grading in these reaches shall be limited to areas outside the required creek setback, with construction implemented so as to protect and preserve the natural site conditions.
2. Minimal grading will be permitted to construct multiple use paths and crossings and low water crossings in reach 'A' west. Mechanical grading should be limited to the smallest piece of equipment reasonable to reduce potential impacts (erosion, sedimentation, soil compaction and loss of vegetation).

3. All other pedestrian trails shall be constructed by manual labor without the aid of mechanical equipment.

Rural Reaches

1. Creek restoration and grading in this reach could include increasing channel width by up to 100' and relocating one or both levees away from the creek to create a naturalized meandering creek pattern.
2. Mechanical grading in these areas shall focus on limiting the areas of environmental impact and providing appropriate mitigation measures to restore the natural creek environment.
3. Where one multi-use soft surface and one multi-use hard surface path are required on one side of the creek, grading should provide a vertical grade separation between paths. Locate the soft surface path closer to the creek.
4. Limit slope of channel banks so as not to exceed 3:1 slope. Slopes flatter than 3:1 are preferred. In areas where the creek channel width does not allow for this degree of slope, engineered terraced walls and vegetative wall systems shall be incorporated into the design to maintain desired hydraulic capacity.
5. Grading operations shall be confined to smallest work area possible for construction of multiple use and low water crossings.

Urban Reaches

1. Provide grading operations as needed to increase channel hydraulic capacity. Restore the creek's native riparian flora and fauna and provide public access for persons of all abilities.
2. Creek restoration in these areas involves increasing channel hydraulic capacity, removing existing rip-rap, laying back or constructing planted crib wall on the south bank, and stepping back the north bank with a series of terraced retaining walls for multi-use, pedestrian and maintenance paths.

CROSS SECTION REACH "C"

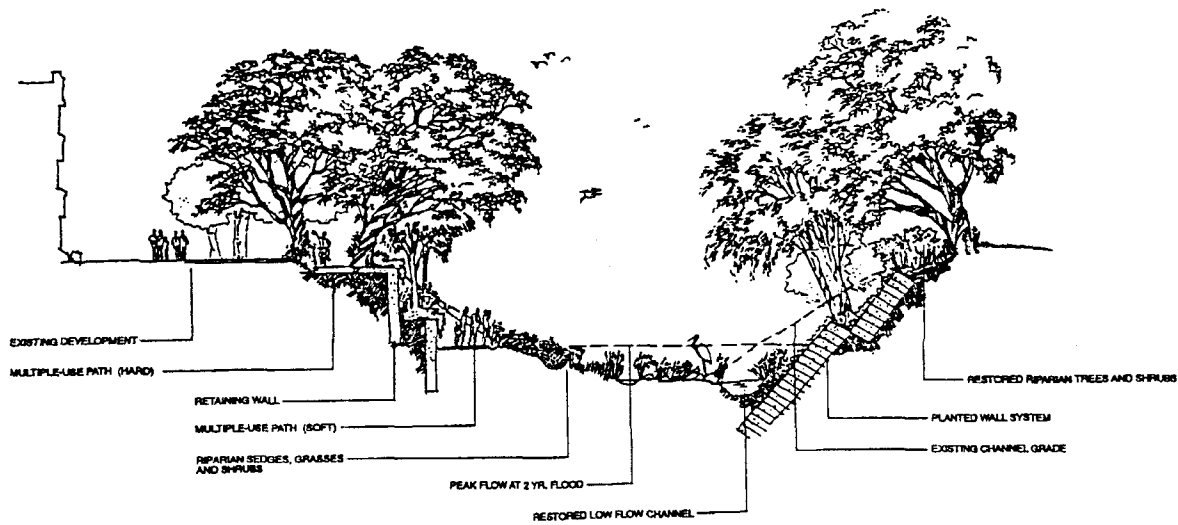

Figure 10
Creek section in Reach "C" showing improvements to increase hydraulic capacity and provide access.

- 3. The greatest amounts of earth retaining will be required in these urban reaches to obtain the desired creek cross section.
- 4. A low flow channel shall be re-routed and directed through a culvert of appropriate size during grading and construction operations. This will allow fish to migrate up or down stream and reduce sedimentation down stream. A culvert shall extend past the limit of work zone to allow equipment and workers to cross the creek without disturbing water quality.
- 3. Replace existing asphalt on bridges with special paving to reflect the creek's water direction and serve as a visual reminder of this amenity.
- 4. Provide elements under bridges or on walls that create a human scale. Incorporate murals or etchings onto plain walls to reduce graffiti and provide a sense of community involvement and pride.

3. CREEK CROSSINGS

Design Objective:

To identify and enhance the significance of the creek greenway, its native vegetation and unique characteristics. To make the creek more identifiable and accessible from streets.

Vehicular Bridge Crossings

- 1. Emphasize the creek greenway as it crosses existing vehicular bridges.
- 2. Use creek logo and signage, pilasters and railings, lighting, natural vegetation patterns and unique characteristics of each particular creek reach to identify creek crossings.

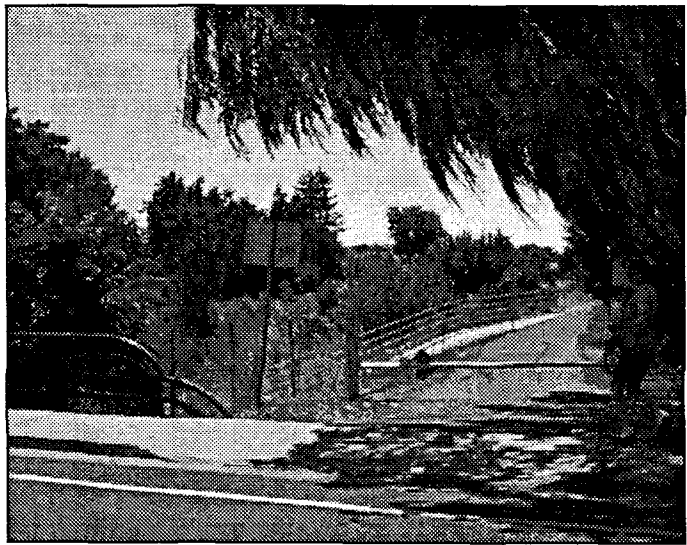
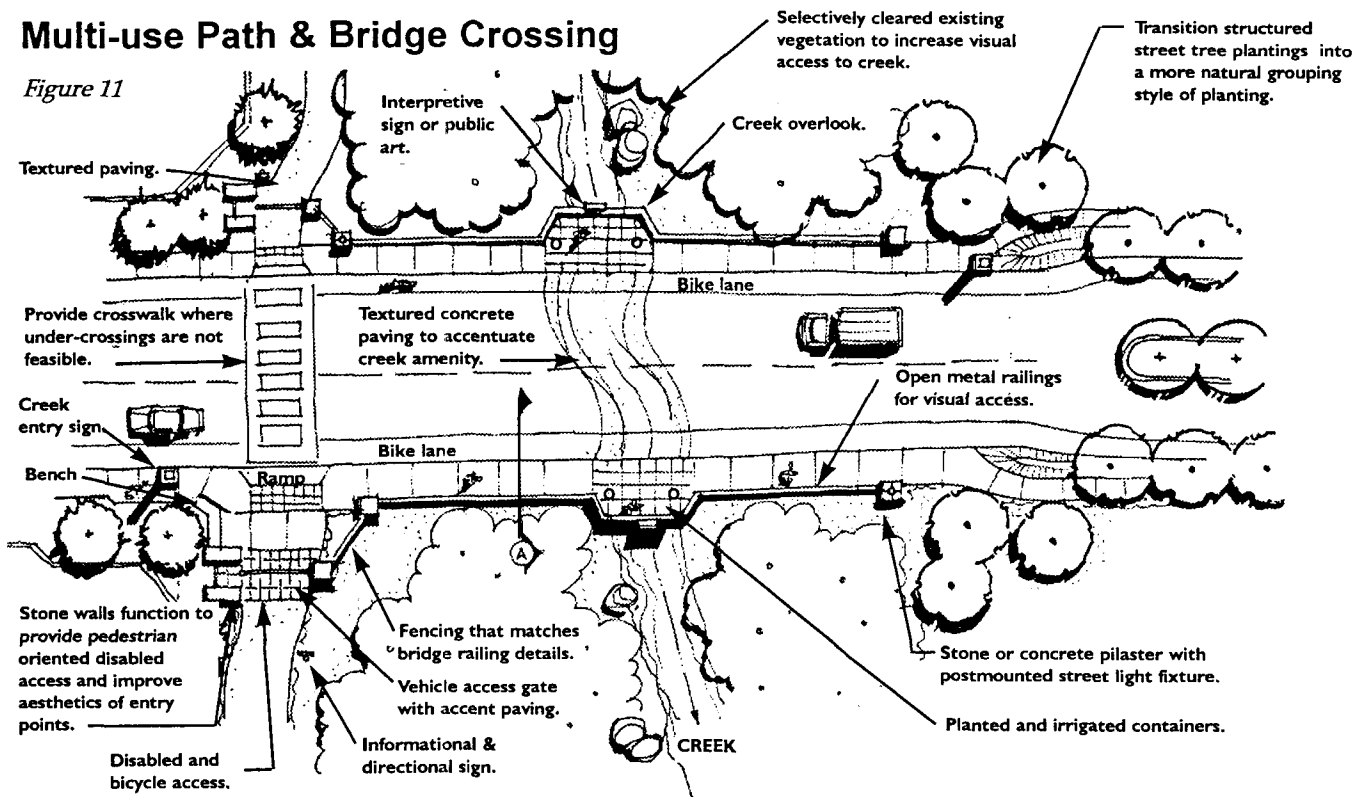

Photo 9
Create a user friendly entrance and identify the creek crossing through the use of logo & signage, lighting, seating & landscaping.

Multi-use Path & Bridge Crossing

Figure 11



Multi-use and Bridge Crossing Section A

Figure 12

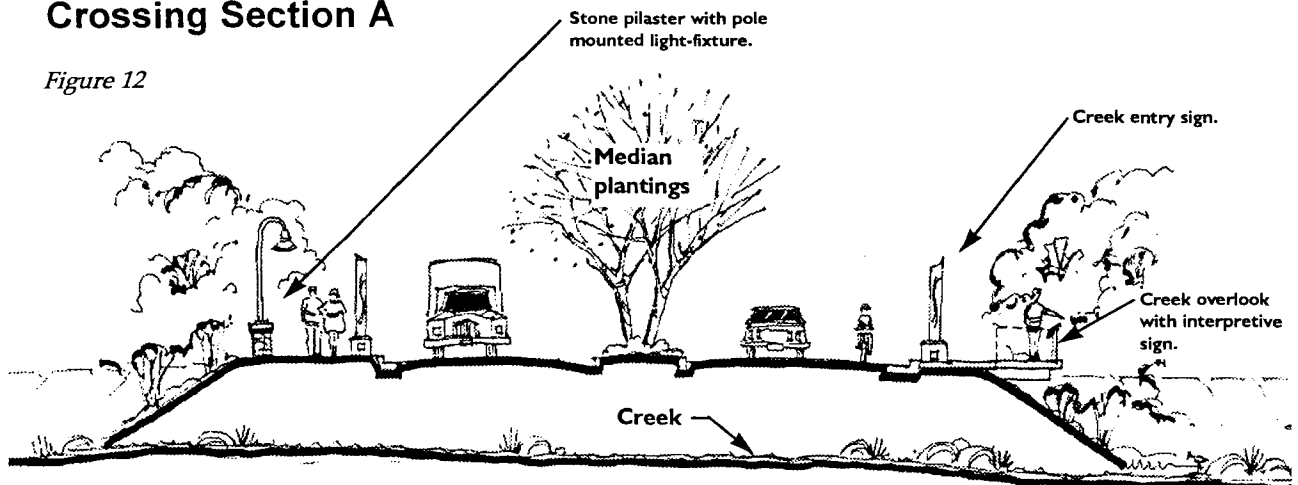

5. Create pedestrian overlooks or view platforms on bridges that promote views into creek zone.

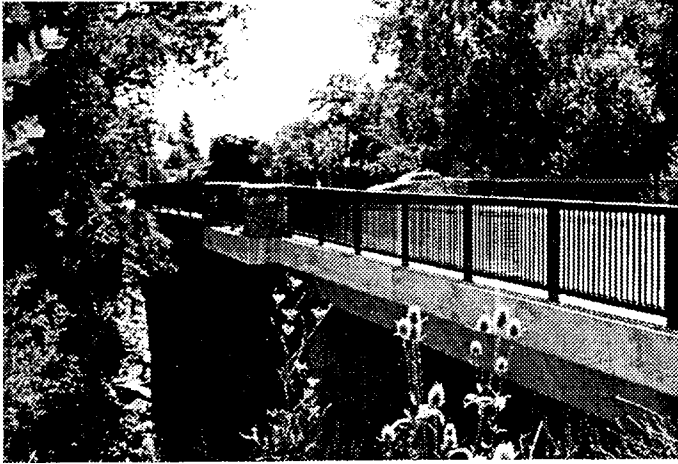

Photo 10
Pedestrian overlook platform on bridge.

6. Break formal street tree plantings into more informal natural vegetation patterns using riparian plant species at road crossings to draw attention to the creek greenway.

Multiple-use Path Crossings

1. Multiple-use crossing shall provide safe high water crossings and year round barrier free access at selected locations along the entire continuous length of the creek.
2. Crossings shall be located to provide a safe visual sight distance for bicyclists, pedestrians, equestrian, and vehicular traffic. Locate multiple-use crossings in areas where a node in the pathway system can be accommodated to allow for benches, drinking fountains, lighting, trash receptacles, and stacking of users to maintain a safe passing condition for other trail users.
3. Crossings should be a minimum of 8' wide and handle the loads of pedestrians, bicyclists, and small emergency and maintenance vehicles.
4. Provide long spans between supports to minimize the obstruction of flood waters.



Photo 11
Locate multiple use pathway crossings in areas with sufficient space to allow for a safe vision triangle, appropriate site furnishings, landscaping and stacking of users.

Materials

1. Bridges for multiple-use crossings shall be constructed of materials that are compatible for that specific reach of the creek.
2. Wood, metal, masonry and concrete (or a combination of these materials) are appropriate materials for bridge construction in the rural and urban reaches. Continuity of design is important.

Bridge Under-crossing

1. Bridge under-crossings are the preferred method of crossing roadways.



Photo 12
Existing pedestrian overpass on Hwy 101.

2. Under-crossings reduce potential conflicts between trail users and vehicles at points where creek pathways cross existing roadways.

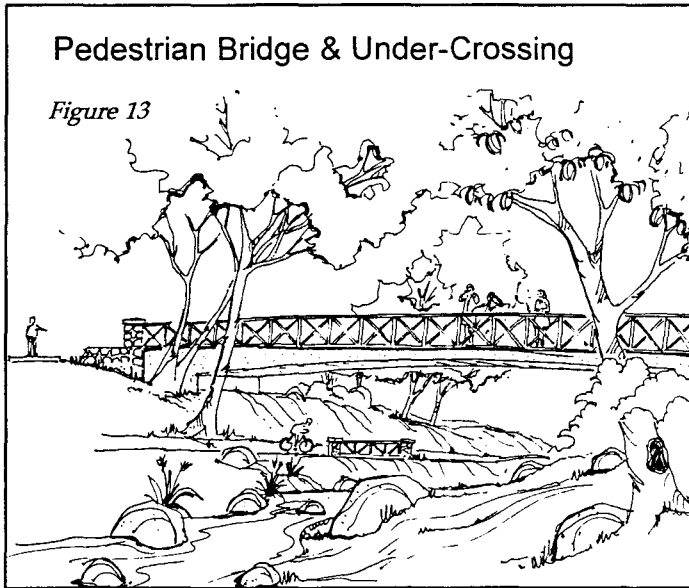

Pedestrian Bridge & Under-Crossing

Figure 13

3. Multi-use paths shall dip down from top of bank into creek channel and join the pedestrian path to safely pass under vehicular bridges.

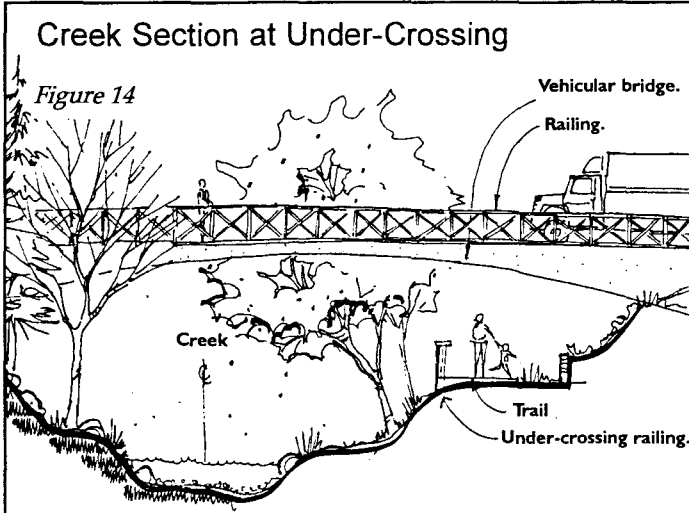

Creek Section at Under-Crossing

Figure 14

4. During storms with high water levels path users would be directed by signs to the nearest location of a safe street crossing.
5. In areas where site conditions prohibit under-crossings, disabled access users must be able to cross at street level as directed by signage.
6. Provide under-crossing railing in areas where required by the ADA or Uniform Building Code.

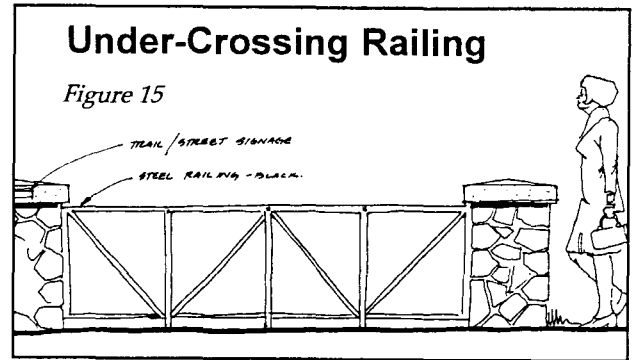

Under-Crossing Railing

Figure 15

Low Water Crossings

1. Low water crossings shall be provided for safe, pedestrian-only trail links during low water periods.
2. Locate crossings in response to circulation patterns, based on land uses or unique creek features where people gather and crossings are desirable.
3. Crossings shall be designed to allow low water flows and sediment/bed-loads to pass and be secure enough to withstand the velocity of high water flows. Set top of pavers at least 4" above low water flow elevation.
4. Provide site furnishings around these areas to promote gathering points in close proximity to the creek. Furnishings could include; seatwalls, shade structures, benches, steps and signage.



Photo 13

Provide alternate route for crossing during high water levels.

Materials

1. In rural and natural reaches low water crossings shall be constructed of wood, stone or other natural materials and securely anchored to channel bed.
2. Examples:
Stone columns (18" diameter X 6' long) set vertical into channel bed. Brooks quarry, Windsor, CA.
Crossings may be natural or concrete or square granite blocks (approximately 2'X2'X2') and securely anchored to channel bed.

If a concrete crossing is preferred, add tan or black coloring additives, and press large native riparian tree leaves or ferns into the top finished surface of stepping stones, to leave an impression and provide a textured safe walking surface.



Photo 14
Natural impressions in concrete.

4. ARCHITECTURE

Design Objective:

To create standards for building development adjacent to the creek resulting in architecture that is complementary to the natural environment of the creek.

Commercial Buildings

1. Buildings shall be oriented toward the creek with pedestrian connections provided from creekside paths to individual buildings located along the creek.
2. Buildings shall be sited and designed to take advantage of creek views. Views from adjacent properties toward the creek must be maintained through the use of notched corners or building setbacks.
3. Multi-story buildings must be stepped back from the creek. Single stories only are permitted directly adjacent to the creek. Buildings over three stories must have a minimum of three "steps" rising from a single story at the creek edge.
4. Permanent screening integrated into the architecture of the building must be constructed for trash, storage and service/loading areas visible from the creek corridor.
5. Building architecture should enhance the pedestrian use of the creek with pedestrian-scaled architectural elements on the side facing the creek. These elements could include recessed entries, arbors, display windows, awnings and signage as appropriate to the use of the building. Large areas of blank exterior walls are undesirable.
6. Outdoor spaces between the creek and buildings facing the creek are required. Outdoor space must be equivalent to a minimum of 5% of the building's street level square footage. Outdoor space may be in the form of a terrace, patio, yard, balcony or other usable space. Views to the creek must be provided from the outdoor space.



Photo 15
Multi-story buildings shall step back from the creek.

7. Use of landscaping between buildings and the creek should complement plant materials used in the creek greenway. Use of native riparian species is recommended. Trellises, arbors, hanging gardens, rooftop gardens and other landscape elements are encouraged.

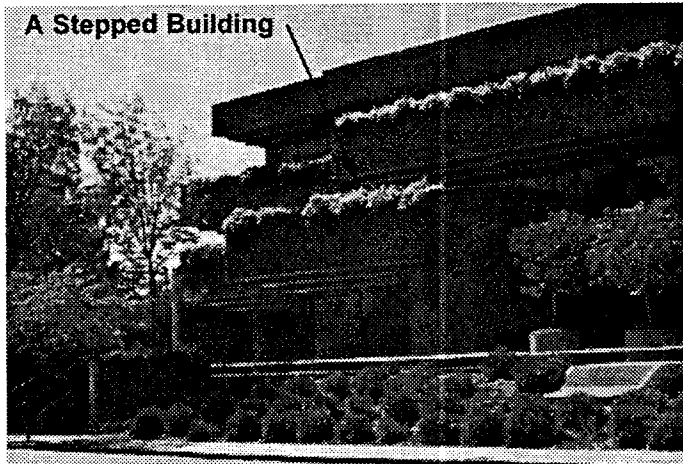

Photo 16
The introduction of plant materials to highlight a building's form is a way to provide more vegetation along the creek corridor.

8. Architectural colors and materials must complement the creek environment. Strong or dark colors are prohibited, as well as reflective finishes. The use of subdued, natural materials and colors is encouraged.

Residential Buildings

1. Residential buildings must be sited and designed to provide views and access to the creek.
2. Multi-story buildings must be stepped back from the creek. Single level stories only are permitted directly adjacent to the creek.
3. Balconies, terraces, rooftop gardens, arbors, yards and patios with views to the creek are encouraged.
4. Landscaping materials must be complementary to the creek environment. Use of native species is recommended.
5. Trash and storage areas must be completely screened from views from the creek corridor.

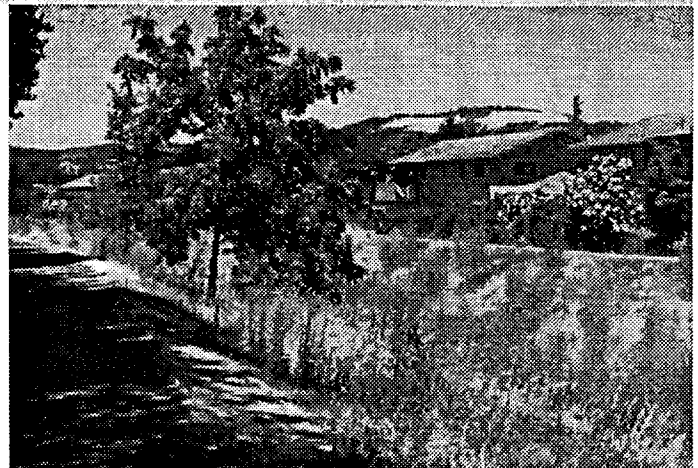

Photo 17
Avoid 2 story buildings adjacent to the creek. Two story structures create privacy issues as well as blocking distant views of the surrounding foothills.

6. Architectural colors and materials must complement the creek environment. Reflective finishes are not allowed. The use of subdued, natural colors and materials is encouraged.

5. SITE FURNISHINGS

Design Objective: To provide attractive, durable site furnishings which promote the use of the creek without detracting from the natural appearance of the creek and surrounding area.



Photo 18
Increase landscaping along existing land uses, such as storage and parking areas that are not compatible with the creek environment.

Benches

1. Benches are to be placed in all reaches: urban, rural and natural.
2. Benches shall reinforce the character of each section of the creek, see City Standard 113. Locate benches strategically to reduce obstacles in circulation patterns.

3. Locate multiple benches in areas where people gather and single benches in places of solitude or special interest.
4. Benches can be the tops of low retaining or seatwalls 14"-18" tall, can aid in defining a space, or can be large boulders strategically placed.

Trash Receptacles

- Incorporate trash receptacles and recycling containers into architectural elements (walls, fences, arbors) to simplify the number of site furnishings and reduce the visual impact.
- Locate receptacles at appropriate areas where people gather, in proximity to vendors/restaurants and at strategic points along the creek.
- In areas where receptacles must stand alone.(See city standard 117).

Bicycle Racks

1. Bike racks are to be placed in all reaches: urban, rural and natural, see City Standard 115.
2. Bike racks shall be located at major points of entry, major creek crossings, major points of interest, trail heads and trailside parks.
3. Locate in visible areas for security and out of the main flow of traffic.

4. Bike storage lockers are not recommended along the creek, but may be utilized at trailheads and trailside parks with proper screening and plantings.

6. CONSTRUCTION MATERIALS

Design Objective:

To select complementary materials that maintain a natural, rural, or urban character based on unique site characteristics and geographic location along the creek.

Design Criteria

1. Material colors shall be compatible with all reaches of the creek and shall be greens, black and earth tones.
2. Selection of materials shall address maintenance costs or repairs and resistance to vandalism.
3. Furnishings shall be selected to be compatible with each reach of the creek, whether natural, rural or urban.
4. Finishes shall be resistant to vandalism, easy to maintain or repair and durable to withstand the elements (sun, rain and time).
5. Furnishings shall be located at points of entries or along the creek corridor to help define nodes, points of interest and crossings.

Benches - Freestanding and Built-in

Figure 16

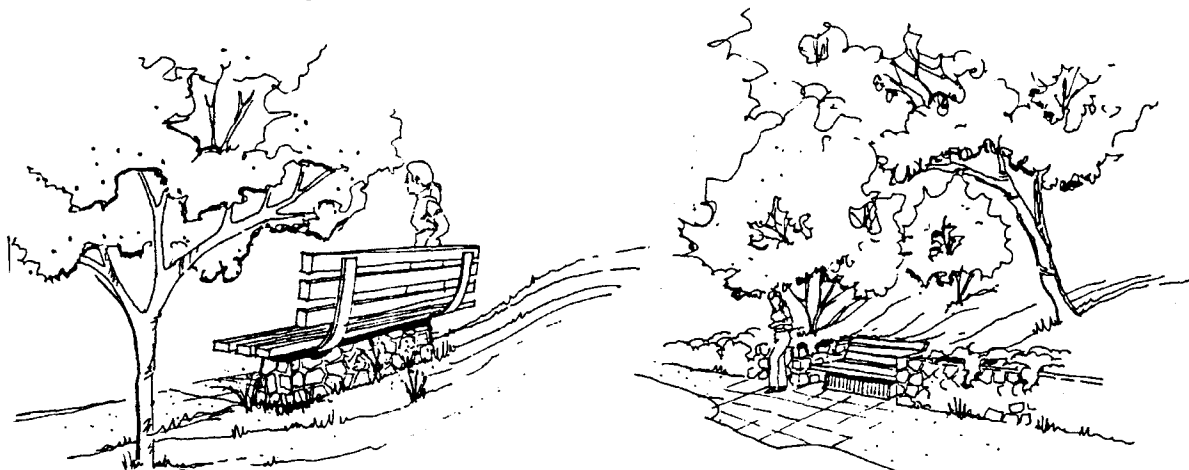

6. Furnishings such as telephones and trash enclosures/receptacles shall have a subdued appearance and be incorporated into architectural elements (trellis, fences or walls) to reduce their visual impact. (see figure 17)
7. Metal may be used if the finish color is complementary to the site character. In most situations this would be dark greens, or black finish colors. Galvanized finishes are not appropriate.
8. Use of reflective materials (mirrored glass or glossy finishes) is not permitted.

Natural Reaches

1. These sections of the creek greenway are considered preservation reaches with some ecological enhancement.
2. Materials in these sections of the creek shall reflect the natural and native creek environment.
3. Man-made elements (walls, benches, paths, railings, etc.) shall be constructed of wood, stone, earth or other natural and native site materials.

Rural Reaches

1. Restoration in these sections includes removal of existing rip-rap and revegetating with native riparian species.
2. Materials in these sections of the creek shall reflect the rural creek environment and adjacent agricultural land uses. Materials must complement those used in other reaches of the creek.
3. Materials must be easy to maintain, long-lasting, and reinforce a rural site character.
4. Man-made elements (walls, trash receptacles, fencing, and benches, etc.) shall be constructed of metal, wood, stone, or concrete. Masonry block and brick are not appropriate for this reach.

Urban Reaches

1. These sections of the creek are located in and around the commercial core of the City, (downtown and Railroad Square). Restoration in these reaches include removing existing grouted rip-rap, replacing southern bank with engineered vegetative crib wall system, and stepping north bank with retaining walls allowing for various pathway systems.
2. Selected materials must integrate commercial uses with restored creek environment.
3. All materials and finishes shall reinforce the unique local, cultural, environmental and/or historic site characteristics.

Historic Railroad Square:

1. Material selections and design of commercial development west of Highway 101 should emphasize the historic character of old Railroad Square.

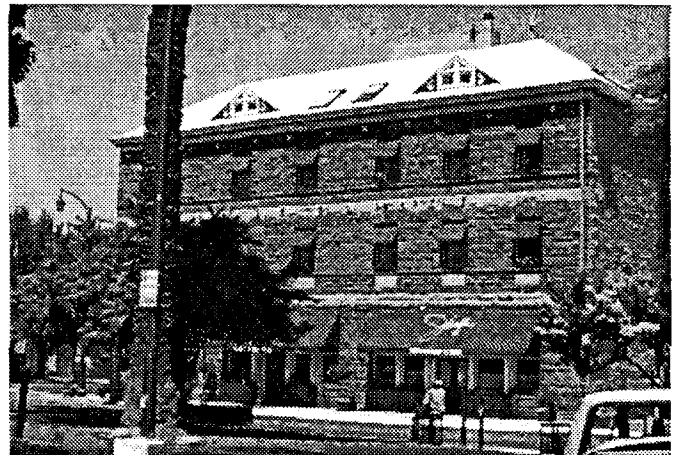
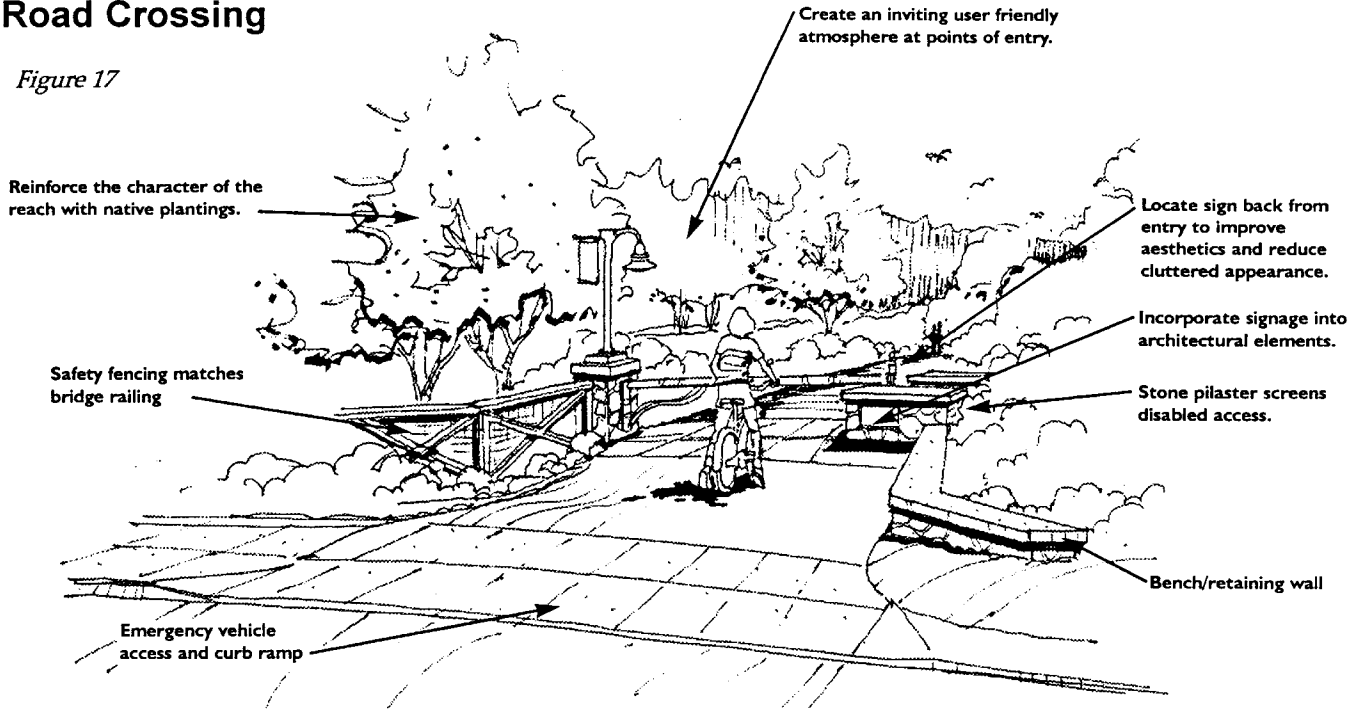

Photo 19
Historical charm of Railroad Square as reflected in the architecture and heritage trees.

2. Materials and forms characteristic of this area include antique style light posts, quarried and cut stone blocks or pavers, grid-scored concrete, ornamental wood or metal railings, fences and late 19th century and early 20th century architectural detailing.

Multi-use Entry Pathway at Road Crossing

Figure 17



City Commercial Core:

1. Construction materials shall be selected to be compatible with the commercial district as well as to integrate with materials from other reaches of the creek.
2. Construction materials shall be metal, wood, stone, brick, concrete or other appropriate materials found in the commercial core.
3. Materials shall reinforce the urban character of the commercial core and emphasize the natural creek character. For example, a commercial use with a creekside plaza along the greenway could have retaining walls that combine urban and natural materials. It could be a combination retaining wall/seatwall for a patio/plaza constructed with native stone veneered stem wall and a concrete pre-cast seat cap. In this case, the natural stone-veneer is compatible with the creek while a concrete seatwall cap could be complementary to the architecture or patio finish.



Photo20

Public plaza oriented along creek at bridge crossings provides a central place for people to gather.

7. PATHWAYS

Design Objective:

To develop a trail system that provides access to all reaches of the creek and is a link between other local and regional trail systems. Trails shall be constructed to standards appropriate for use, site conditions and safety, and shall be environmentally and aesthetically sensitive.

Pathway Sections

Figure 18

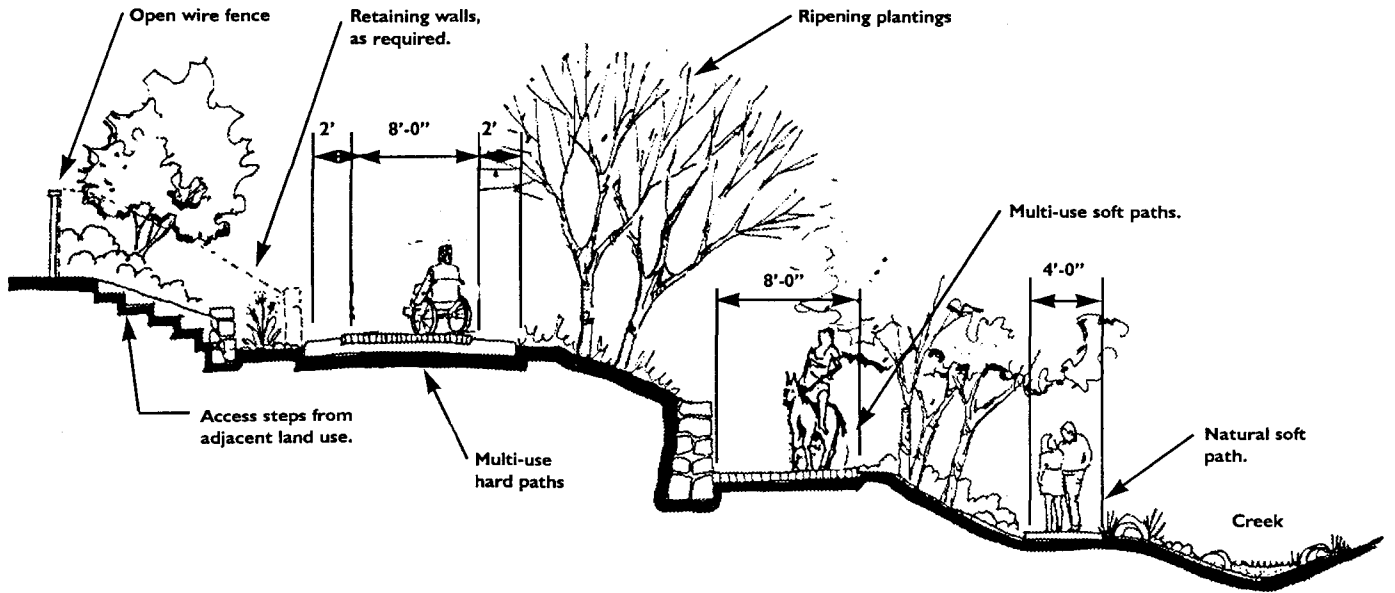

General Recommendations

1. Paths within the low flow channel shall not be surfaced due to exposure to annual flooding and washout.
2. Paths must comply with Title 24 Standards and the American Disabilities Act for Barrier Free Access.
3. Select materials that reduce maintenance costs. Locate paths at various elevations to reduce potential for washout.
4. Layout paths to preserve safe sight distances to meet requirements of intended user groups and to be environmentally and aesthetically sensitive to topography.

Multiple-use Soft Paths (8' width minimum)

1. Provide paths to serve pedestrians, equestrians, and bicycles.
2. Accommodate E.V.A. and maintenance vehicles in reaches D-G.
3. Locate in creek channel above 2-year storm water level to reduce potential for washout or locate on top of bank.

4. Provide accent paving at entry points, such as where pathway intersects public roadways or another pathway.

Acceptable Materials:

Decomposed granite, crushed and compacted rock, wood chips, and earth.

Multiple-use Hard Paths (8' width minimum, with 2' shoulders)

1. Provide barrier-free access for people of all abilities.
2. All-weather surfaces shall be constructed of smooth, hard, all-weather material.
3. Provide pull-outs or nodes for seating and gathering at special points of interest and where site conditions favor this use.
4. Locate path outside the riparian zone to minimize impact on fish, wildlife and vegetation, except at bridge under-crossings.
5. Provide a 14' minimum height clearance from finish grade.

Node in Multi-use Path

Figure 19

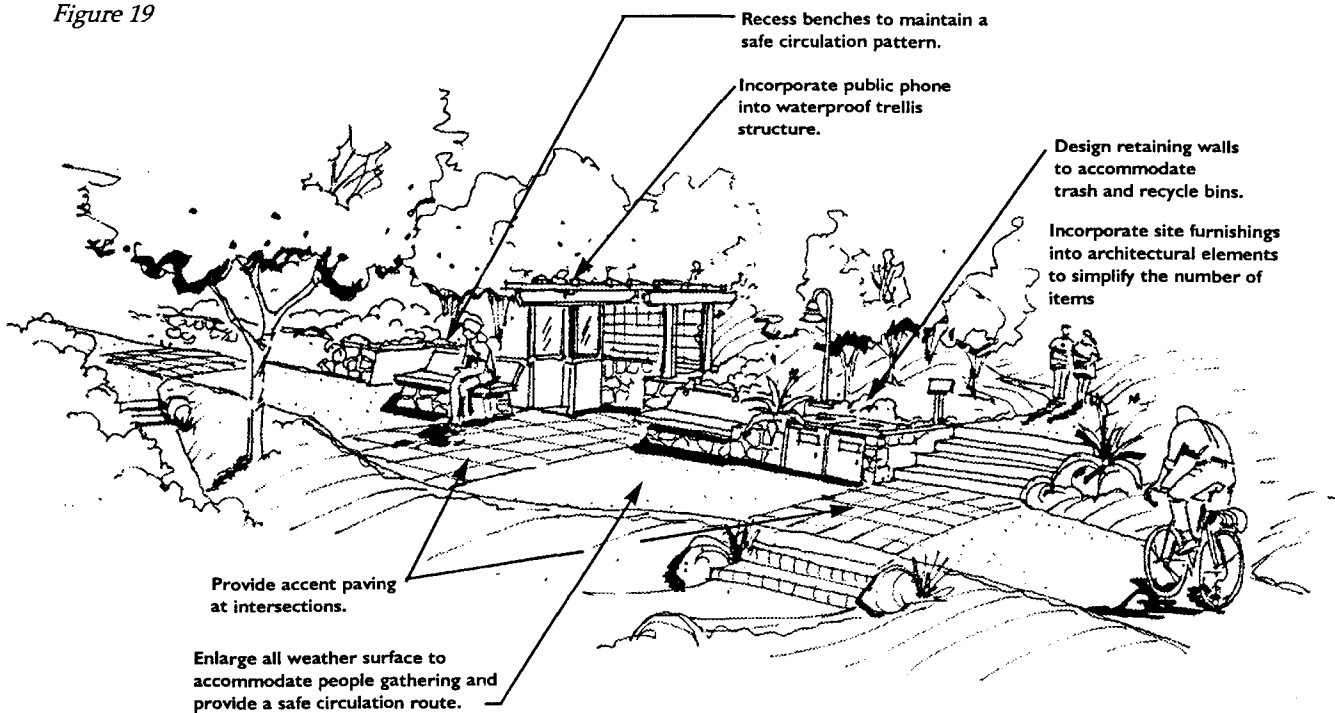

6. Where existing or natural structures prevent the multiple use path from being located outside the riparian zone, it may be located on the channel bank for a short period (providing there are no environmental impacts or they are fully mitigated).
7. Acceptable Materials:
Concrete, asphalt, 3/8" minus compacted shale and stone cobbles.

Natural Soft Path (4' width minimum)

1. Locate near creek above 2-year flood level wherever possible to reduce washout repairs and maintenance costs.
2. Provide at least 8' minimum height clearance from finish grade.
3. Create areas along path for pedestrian amenities (tables, benches, drinking fountains) and creek access based on site conditions, points of interest and low water crossings.

4. Steps, where required, shall be constructed of stone, wood or other natural material that is appropriate to the particular reach of creek.
5. Acceptable Materials:
Stone, earth, wood chips or other appropriate, natural materials

On-Street Connectors

1. These connectors consist of class 1, 2, and 3 bicycle routes as designated by the General Plan or by a Bicycle Masterplan.
 - **Class 1:** Separate, off-street paths or trails.
 - **Class 2:** On-street, but separated from motor vehicles by lane marking.
 - **Class 3:** On street and only designated by signs.
2. Provide creek signs and logo where connections intersect greenway.

Entry Point Identity Sign - Plan View

Figure 20

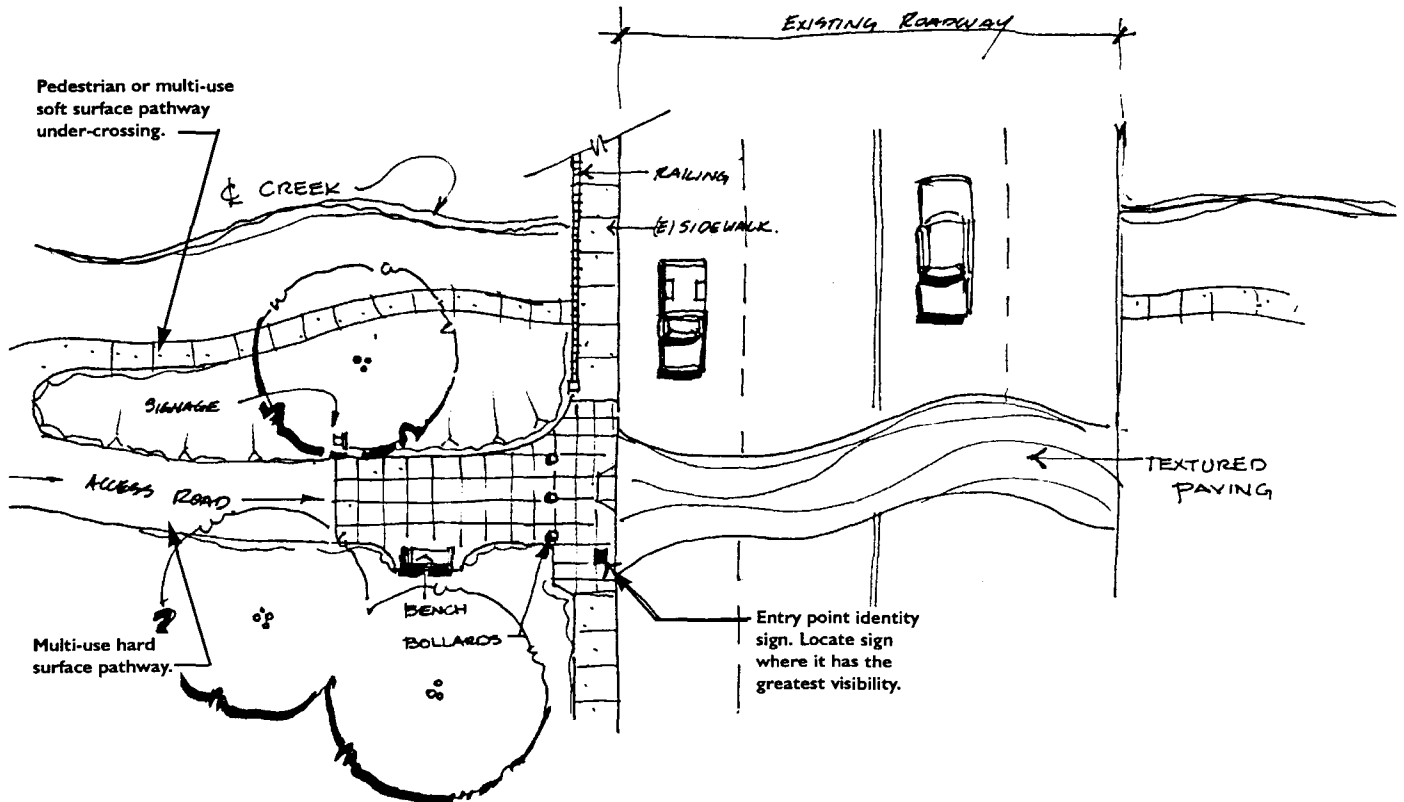

Cantilevered Boardwalk Path (4' width minimum)

1. Locate at all points along the creek where conditions make it undesirable to have a path on bank (such as steep banks) provided there are no environmental impacts or they are properly mitigated.
2. Wood or metal cantilevered boardwalks or pier-supported decking and railings should be designed to minimize hydraulic impacts and maintenance. These types of paths would most likely occur in reaches A, B and C.

2. The logo appears on entry point signs, directional signs and informational signs. Additionally, the logo will appear on pamphlets, stationary, and other appropriate uses. See City Standards 118.

8. LOGO

Design Objective:

To create a graphic image of the Santa Rosa Creek for use on signage, pamphlets, stationary, etc.

Description

1. The logo is an abstracted symbol of a linear waterway.

9. CREEK SIGNAGE

Design Objectives: Entry point signs will create a strong visual marker for major access points to the creek and road crossings. Informational and directional signs will convey the required information while blending into the natural environment. Signage will be consolidated and minimized to the greatest extent possible. (See Figure 20, page 30)

Entry Point Identity Signs

1. The entry point sign was designed as a vertical element located at the curb in order to maximize its visibility, minimize obstruction of views from the road to the creek, and to fit within the limited spaced available at entry nodes. The design allows the sign to be viewed above automobiles parked at the curb and to fit in with other vertical streetscape elements (street lights, street signs, telephone poles, etc.).
2. The entry point sign is a hollow bronze column on a concrete base. The base incorporates a pathway light on two sides. The logo is cut out of the column and lined on the inside with white plexiglass. Internal illumination, will radiate the logo during the night. On the two sides of the column perpendicular to the street the creek logo is displayed. "Santa Rosa Creek" appears on the side of the column directly facing the street, and the street crossing name appears on the opposite side facing the trail. See City Standard 110.

Informational Signs

1. Informational signs include signs on educational, historical or environmental topics and on user regulations. Sign information shall be condensed as much as possible. A minimal number of signs will be erected. Signs will be located near entry points and in areas not blocking views or circulation paths to the creek.

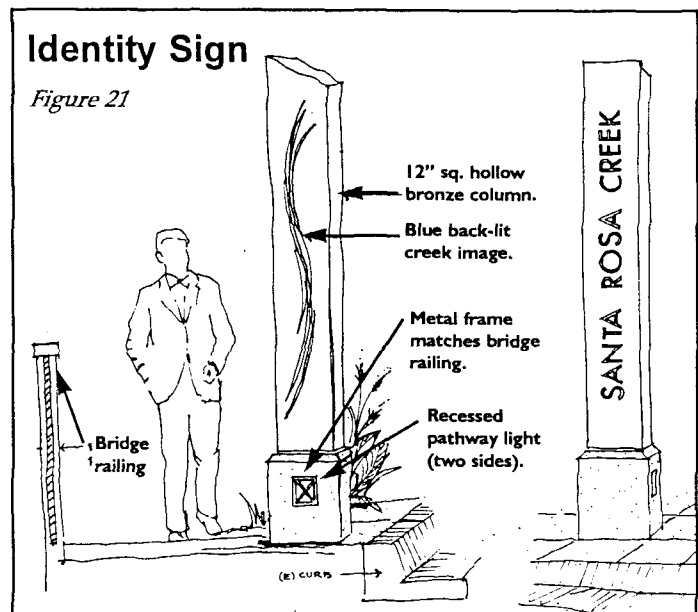

2. Recess signs at points of entry to avoid cluttered appearance.
3. Informational signs will be etched aluminum sign faces covered with clear plexiglas placed within metal frames and supported by 6" X 6" redwood posts. The signs will be slanted in order to minimize height and maintain legibility. See City Standard 111A.

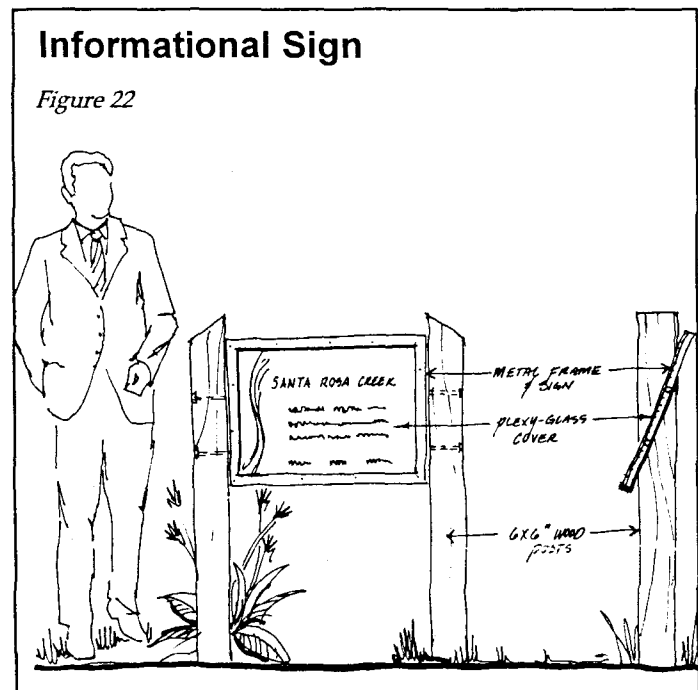

Directional Signs

1. Directional signs include traffic signs and signs denoting pathway uses. The location of the signs is dictated by their use. These will be stamped 4"x4" square aluminum signs, blue images on a black background, attached to 6" X 6" wood posts. See City Standard 111B.

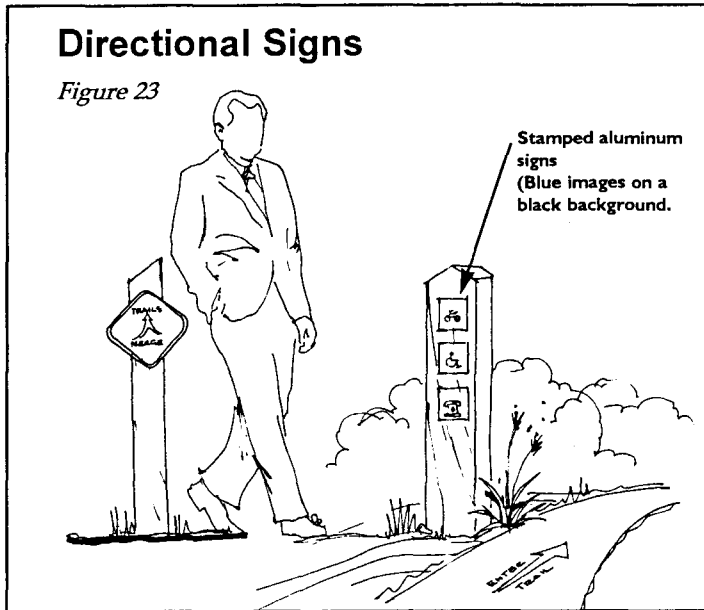

Directional Signs

Figure 23

2. Images for these signs shall be universally recognized symbols which communicate graphically, quickly, and distinctly, the information needed by people in the creek corridor. Use symbols developed by the U.S. Department of Transportation or the A.D.A.

10. TRAILHEADS AND TRAILSIDE PARKS

Design Objective:

To develop trailheads and trailside parks that act as a public access or gathering point to enhance the recreational aspect of the creek greenway.

Trailheads

1. Trailheads shall be designed to enhance the image of the creek greenway and provide public access.
2. Trailheads must blend in with surrounding community character, maintain privacy of adjacent land uses, and be clearly identifiable from the road.

3. Trailheads may contain all or some of the following features:
 - Parking (25 vehicles and horse trailers maximum)
 - Creek logo and signage
 - Interpretive displays
 - Restrooms/Water
 - Picnic facilities
 - Trash receptacle
 - Earth berms
 - Irrigation and landscaping
4. Screen views of vehicles and horse trailers from road and conflicting land uses with earthen berms and low maintenance landscaping.
5. Plant trees to shade parking lot, cars, and people spaces/picnic areas.
6. Provide all-weather surface for parking areas, lanes of travel, and disabled parking.

Trailside Parks

1. Trailside parks shall be located and designed to enhance the image of the creek corridor and provide public access.
2. Depending on the location along the creek, the trailside parks should emphasize a 'sense of place'. These improvements shall reflect significant historical, archeological and cultural aspects of the site, (for example, Native American Indians, early settlers - Carrillo Adobe, and agrarian ancestries).
3. Trailside parks may contain some or all of the following site furnishings:
 - Trellis
 - Benches
 - Tables
 - Trash receptacles
 - Historical/interpretive displays
 - Drinking fountains
 - Disabled access
 - Parking
4. Provide architectural or vegetation buffers between parks and adjacent non-compatible land uses.

Hall Road Trail Head

Figure 24

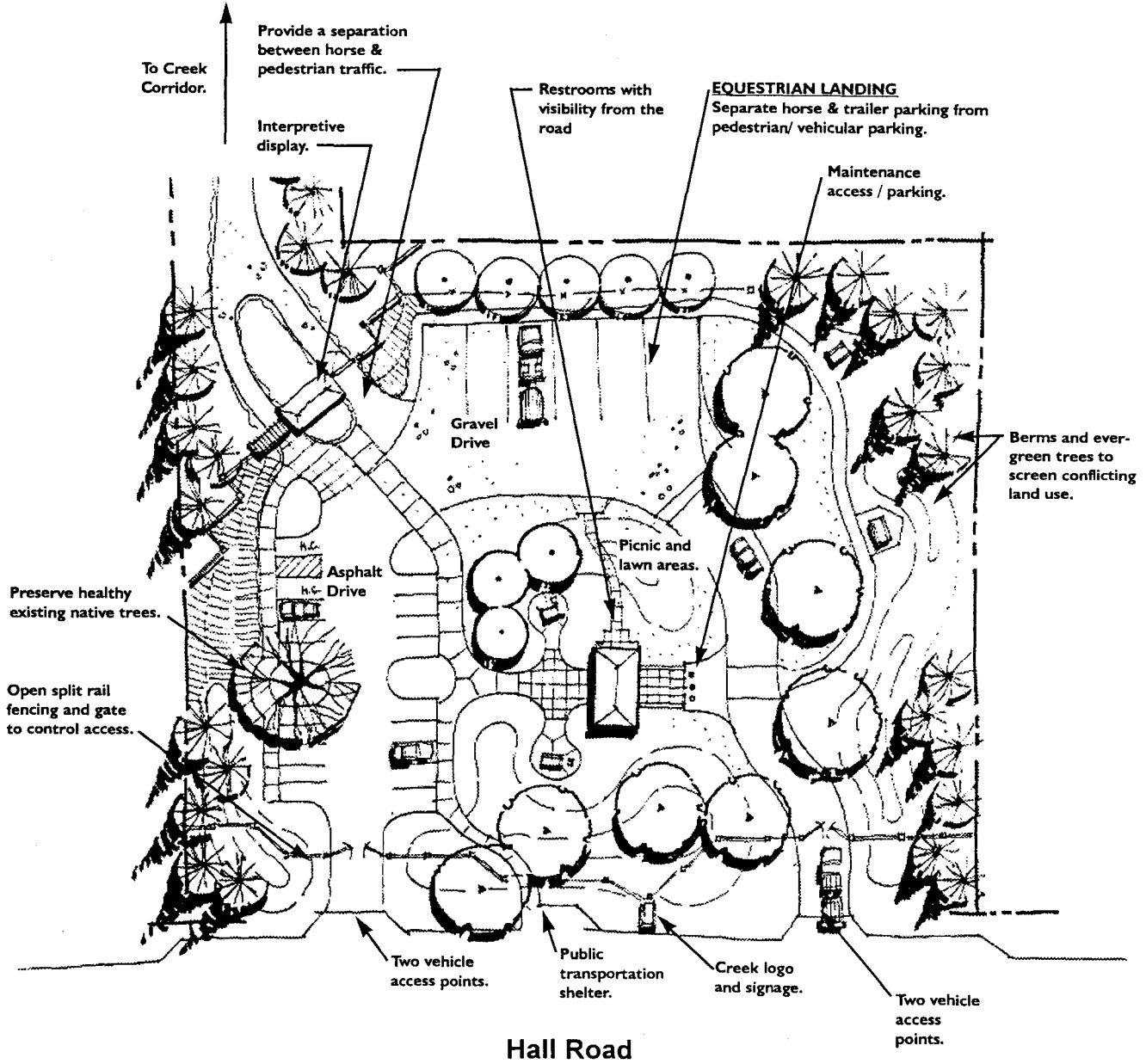

5. Use appropriate low maintenance native and ornamental plantings. See Section 12 and figure 26 for a list of recommended plant materials.
6. Plants that reinforce specific cultural and historical characteristics may be used in areas deemed appropriate by the City.
7. Provide park identification signs that are visible from trails along the creek or the nearest road access point.
8. Vehicle access shall be provided for maintenance and patrol personnel.

3. In areas where people gather or at access points, lighting shall be sufficiently located to safely illuminate these areas with fixtures that are scaled for pedestrians. These areas shall be illuminated along the walkway. Use traditional wall mount, or single or twin-mounted lights on post.
4. Light fixtures with banners can be included for a festive or seasonal atmosphere. See City Standard 112A.

11. LIGHTING

Design Objective:

To provide adequate pathway illumination for safety and evening use of designated sections of the creek. All light sources must include the following :

- Light sources shall be shielded, louvered or cut-off, to prevent direct glare from affecting pedestrians or vehicular traffic.
- Light sources shall not be visible from adjacent land uses.
- Illumination should focus on architectural elements or highlighting trees and vegetation rather than the pathway.

5. Pathway lighting shall be such that it illuminates a safe lane of travel for pedestrians with the minimal number of fixtures. Locate these lights uniformly along paths, at steps, grade changes, intersections and elsewhere as needed to provide a safe pathway. See City Standards 112B.
6. In areas with walls or architectural elements that require lighting use a wall niche light to replace the bollard type pathway light. See City Standards 112C. This will reduce the amount of clutter and simplify the number of amenities along the trails.

Rural and Natural Reaches

1. Lighting in these areas shall be avoided. Any lighting shall be limited to trailheads and trailside parks, points of access, or areas with security concerns.

Urban Reaches

1. Lighting in these areas shall be subtle in nature while providing adequate illumination for safety and security.
2. Existing cobra head street light on bridges and roadways that have a direct relationship with the creek corridor shall be relocated or replaced with a pole-mounted light fixture or Santa Rosa Creek entry sign to maintain continuity of the creek corridor.

Figure 25

Street Tree Plantings at Creek Crossings

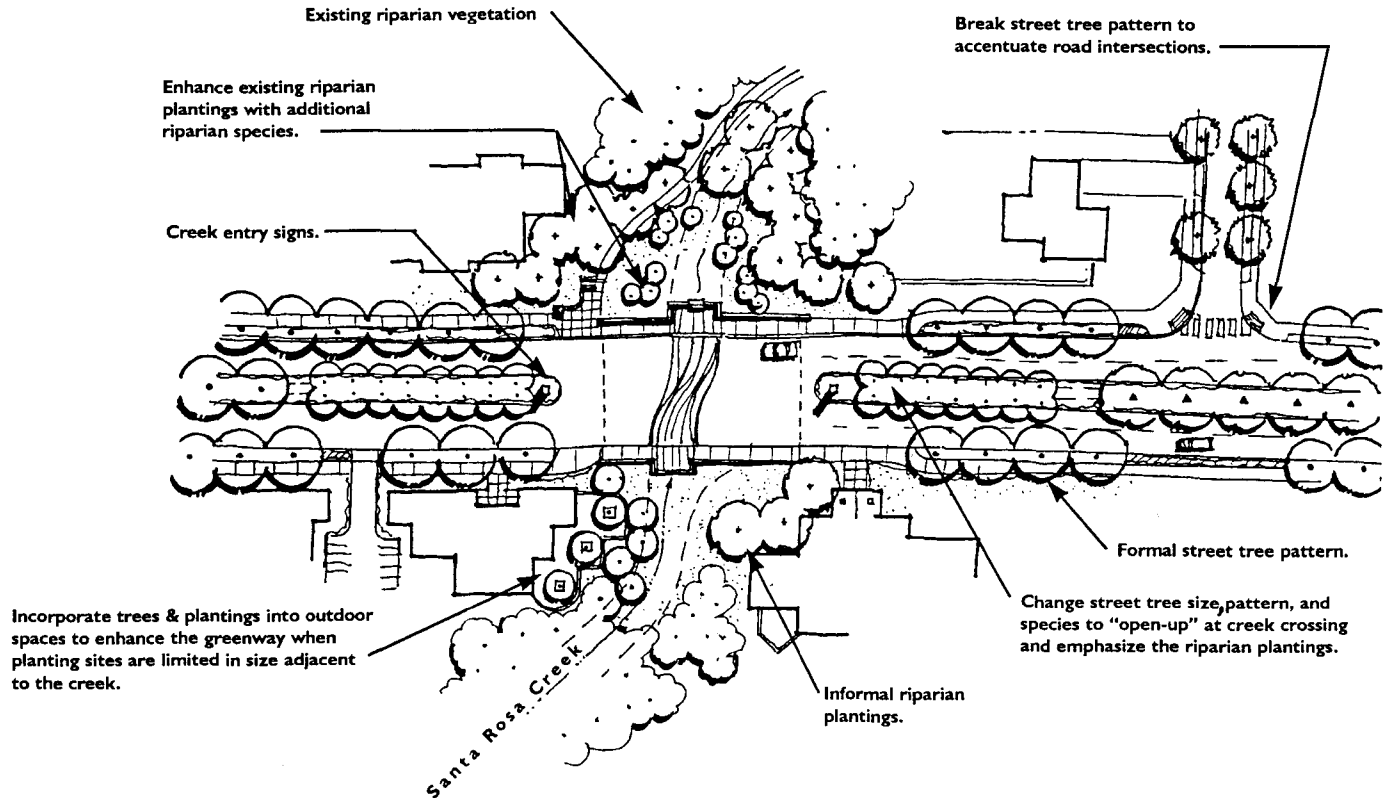

This plan demonstrates how the street tree plantings can emphasize the creek, enhance the native riparian vegetation, and maintain continuity at other creek crossings.

12. LANDSCAPING AND PLANT MATERIALS

Design Objective:

To restore and create a creek corridor that reflects the native character of the creek, complements adjacent land uses and enhances environmental conditions in and along the creek for wildlife and the community.

Planting Zones

1. **Riparian creek area** - use native plant revegetation schemes.
2. **Road/bridge crossings** -emphasize the significance of the creek at street level, with informal planting concepts in masses.
3. **Major arterial and City gateway entry points** - emphasize the significance of the creek and gateway to Santa Rosa with formal planting concepts.

4. **Creek-oriented commercial areas** - combine compatible native and ornamental plantings to provide a transition zone.
5. **Pathway nodes or intersections** - combine natural and informal planting concepts to reinforce a 'sense of place' unique to that section of the creek.

Recommendations

1. Ecological planting zones: plants must be horticulturally compatible with proposed location. Select native plants that will be designed and installed into zones which match their tolerance of the different moisture levels.
(See Figure 26, 27 on page 37 & 38)

2. Respect hydrological zones: these zones are where planting schemes must comply with the hydrological capacity of the channel and long term maintenance needs for maintaining a low flood hazard potential (see Figure 26 & 27, Hydrological Zone B-1, B-2).
3. Create a 'sense of place' at entry and access points.
4. Control bank erosion and reduce sedimentation of creek channel.
5. Remove introduced plants (ivy, locust, etc.) and replace with native species.
6. Provide shade canopy from tree plantings along creek, especially on the south side of the creek.
7. Use native plants that restore riparian woodland and wildlife habitat.
8. Locate and select plants based on their ability to survive when planted in appropriate hydrologic planting zones.
9. Plants must have low maintenance, disease and pest resistance, and drought tolerant characteristics.
10. Maintain safe sight distances for vehicles, bikes, pedestrian and equestrian traffic.
11. Locate informal massings of plant materials along riparian corridor that undulate up or down slope and relate to topography.
12. Leave fallen trees where appropriate to provide animal habitat and improve soil fertility.
13. Provide selective pruning and tree removal to create views into the creek from roadways/bridges and overlooks.
14. Provide seasonal interest and contrast in leaf color and texture.
15. Develop planting schemes at points of entry that reflect the character of that section of the creek:
 - **Old Railroad Square Area**
- historical plant materials.

- **Urban Areas** - trees planted in rows or on a grid representing the agricultural heritage of the community.
 - **Road Crossings of the Creek** plant materials and informal massings should enhance the riparian corridor.
16. Lawn areas should not exceed 30% of the landscaped areas unless necessary for the function of the outdoor space.
 17. Lawn may be used in appropriate areas such as public gathering places and trailside parks. Do not place lawn on slopes greater than 5:1 slope. Use drought tolerant and disease resistant Dwarf Fescues in sunny locations.

13. FENCING

Design Objective: To maintain a visual connection to the creek from adjacent land uses while providing necessary security, privacy and screening of undesirable views or uses.

Recommendations

1. An open transparent type of vinyl coated wire fencing is preferred along the creek with plant materials providing the necessary visual barrier.
2. Depress the grade of pathways adjacent to residential properties to reduce height of fence and preserve privacy.
3. All fencing shall be softened by the addition of suitable plant materials on the creek side of the fence.
4. Four foot tall fences are preferred with 6' being the maximum height allowed above finished grade, (where deemed appropriate by the City).
5. Use stone masonry columns along entire length of fence to accent points of entry to the creek. Columns should be an extension of an architectural building material and may support approved signage and lighting.

Typical Revegetation Scheme for Urban Reaches "C", "D", and "E"

Figure 26

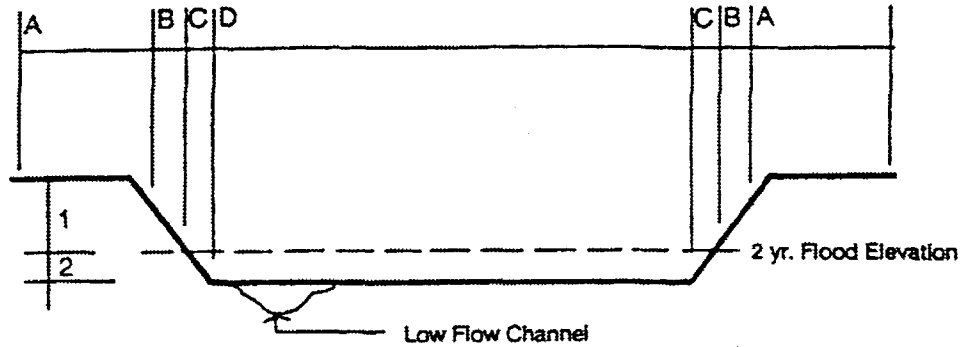

<u>PLANTING ZONES</u>		<u>MOISTURE REGIME</u>	<u>PRINCIPAL PLANT SPECIES</u>
A	Top of Bank	Xeric (dry)	Live Oak, Valley Oak, Madrone, Bay, Manzanita, Ceanothus, Native Bunch Grasses and Wildflowers
B	Mid-Bank	Mesic (intermediate)	Valley Oak, Black Oak, Buckeye, Maple, Elderberry, California Rose, California Blackberry, California Grape, Snowberry, Native Grasses and Wildflowers
C	Lower-Bank	Hydric (seasonally wet)	Alder, Cottonwood, Willow, Ash, Boxelder, Elderberry, Maple, Snowberry, California Rose, California Blackberry, California Grape, Native Herbs
D	Channel Bottom	Hydric (perennially wet)	Elderberry, California Blackberry, California Grape, California Rose, Snowberry, Sapling Willows, Native Wetland Grasses, Sedges, Tules, Rushes, Cattails, and Bur reed
<u>HYDRAULIC PLANTING ZONES</u>		<u>PRINCIPAL PLANT SPECIES</u>	
1	Above 2 yr. Floodplain	Elderberry, California Blackberry, California Grape, California Rose, Snowberry	
2	Below 2 yr. Floodplain	Grasses, Tules, Cattails, Snowberry, California Rose, California Blackberry, and Fishery Enhancement	

(Source: Santa Rosa Creek Master Plan)

Typical Revegetation Scheme for Rural Reaches “F”, and “G”

Figure 27

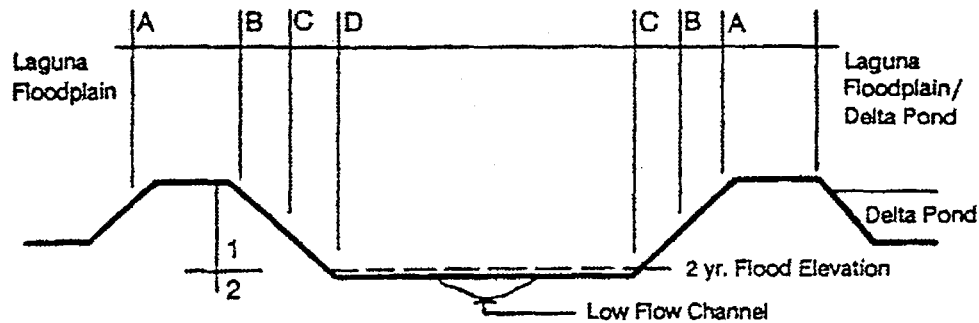

<u>PLANTING ZONES</u>		<u>MOISTURE REGIME</u>	<u>PRINCIPAL PLANT SPECIES</u>
A	Top of Bank	Xeric (dry)	Live Oak, Valley Oak, Bay, Black Oak, Madrone, Manzanita, Ceanothus, Bunch Grasses, Native Wildflowers
B	Mid-Bank	Mesic (intermediate)	Valley Oak, Black Oak, Buckeye, Maple, Elderberry, California Rose, California Blackberry, California Grape, Snowberry, Native Grasses and Wildflowers
C	Lower-Bank	Hydric (seasonally wet)	Alder, Cottonwood, Willow, Ash, Boxelder, Elderberry, Maple, California Blackberry, California Grape, California Rose, Snowberry, Native Herbs
D	Channel Bottom	Hydric (perennially wet)	Alder, Cottonwood, Willow, Ash, Boxelder, California Blackberry, California Rose, Snowberry, Elderberry, California Grape, Sappling Willows, Native Wetland Grasses, Tules, Sedges, Rushes, Cattails, Bur reed
<u>HYDROLOGIC PLANTING ZONES</u>		<u>PRINCIPAL PLANT SPECIES</u>	
1	Above 2 yr. Floodplain	Alder, Cottonwood, Willow, Ash, Boxelder, Elderberry, California Blackberry, California Rose, California Grape, Snowberry	
2	Below 2 yr. Floodplain	Alder, Cottonwood, Willow, Ash, Boxelder, California Blackberry, California Rose, Snowberry, Elderberry, California Grape, Grasses, Tules, Cattails, Bur reed and Fishery Enhancement	

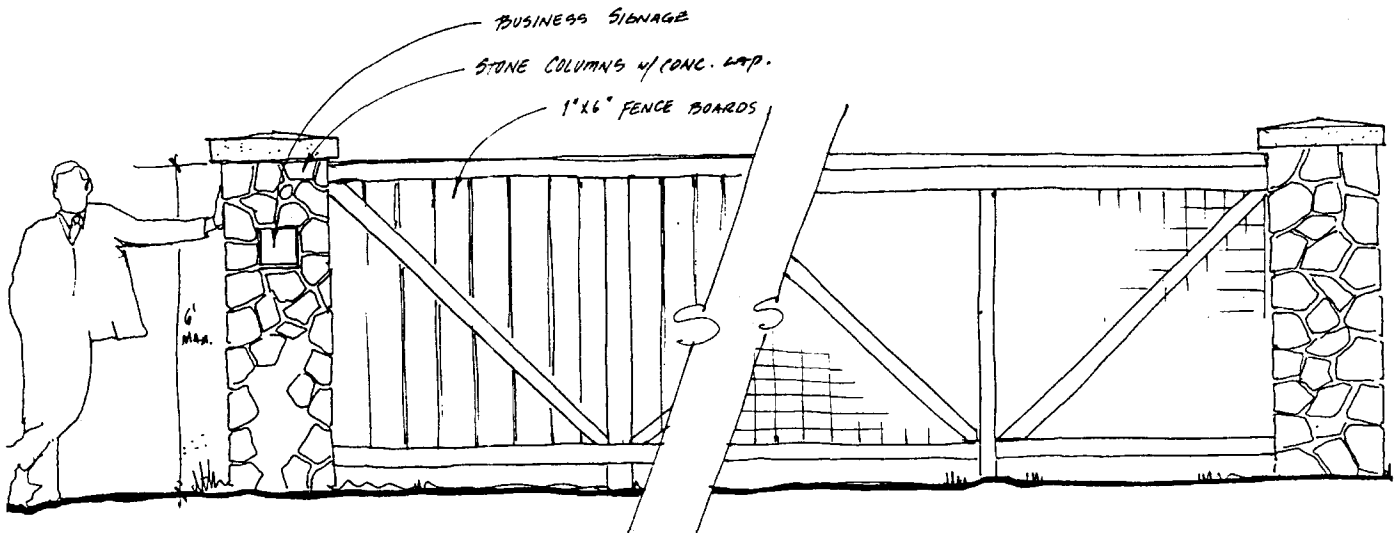

Screening and Privacy Fence

Open Wire Security Fence

Figure 28

6. Provide lockable access gates in fences to areas where privacy or security is required.

3. Avoid locating solid fences in areas where adjacent property owner views of creek are restricted.

Solid Fencing

(Limited to urban and rural reaches)

1. Use to screen existing conflicting land uses. These are uses that do not enhance the creek setting.
2. Use to screen trash and service areas from creek or street views.

Open Wood Framed and Wire Fencing

1. Use where security is required and visual access to the creek is desired.
2. Use for access roads and cul-de-sacs (where fencing is required) to maintain a view corridor to the creek.
(See Figure 28, above)



Photo 20
 New development needs to allow greater setbacks for vegetation buffers.

Materials

1. Fences shall be constructed using materials that are indigenous to the creek environment:
 - **Wood:** Rough-sawn or milled redwood, cedar, or pressure treated wood. Stain pressure treated wood to mask any green coloration.
 - **Metal:** Paint or powder-coat with black or dark green finish
 - **Wire fencing:** Black vinyl coated, non-climbable style fencing.
 - **Stone:** Indigenous material to this geographic area.

14. IRRIGATION

Design Objective:

To provide the necessary moisture requirements to establish and maintain new and existing plant materials in a healthy growing condition.

Irrigation Zones

1. **Natural creek reaches** - irrigate to establish plantings (3-5 years minimum). Provide permanent or temporary means of watering.
2. **Rural creek reaches** - provide permanent and/or temporary irrigation systems.
3. **Urban creek reaches** - provide permanent irrigation systems.

Recommendations

1. Provide automatically controlled drip or spray irrigation systems for all new urban and rural plantings that meet City of Santa Rosa Recreation and Parks Standards.
2. Provide temporary drip or spray irrigation systems to establish plantings in natural creek reaches.
3. Use reclaimed water where available.
4. Minimize water usage to meet the City's Water Efficient Landscape Ordinance. Accomplish this through the use of low flow irrigation systems and native or drought tolerant plants.
5. Install in-line check or swing valves to reduce low head drainage or control erosion from breaks in irrigation pipes.
6. Use irrigation control systems with flow sensors that detect breaks in irrigation systems to reduce potential erosion and washout.
7. Use bubblers or drip irrigation systems in natural and rural areas of the creek to establish new trees and shrub planting on a temporary basis, *until plants can survive on natural precipitation.*

8. Avoid summer irrigation of existing native trees found in a preservation area that is not tolerant to this condition.
9. Use low flow spray heads so that the precipitation rate will not exceed the absorption rate of the soil and cause runoff and erosion problems.
10. Adjust spray heads to avoid overspray onto buildings or pathways.



Chapter III

Santa Rosa Creek City Standards

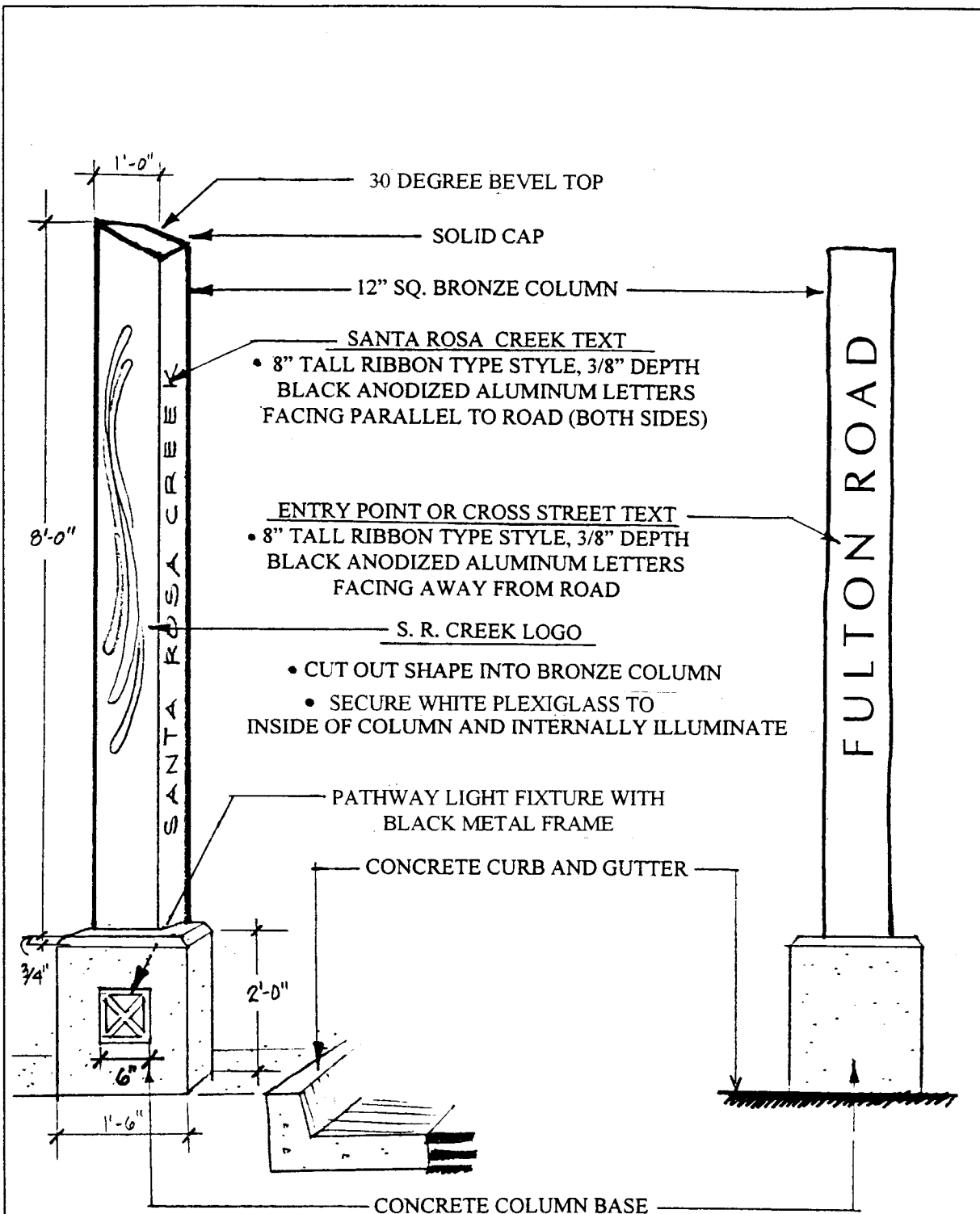

CITY OF SANTA ROSA		
Santa Rosa Creek Standards		
Entry Signs		
Scale:		Date:
DWN	APPROVED	FILE NO.
CHK		STD.110

Adopted _____, 1997
by City Council Res. # _____

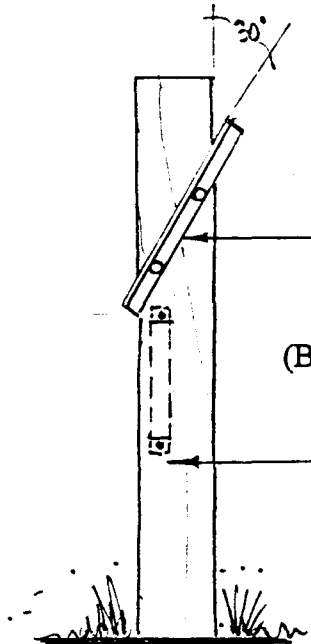

ETCHED ALUMINUM SIGN
 COVERED W/ 1/4" THICK PLEXIGLASS
 1/4" X 1" STANDARD FRAMES
 (BOLT TOGETHER WITH SIGN IN MIDDLE)

6X6 REDWOOD POST

SIDE VIEW

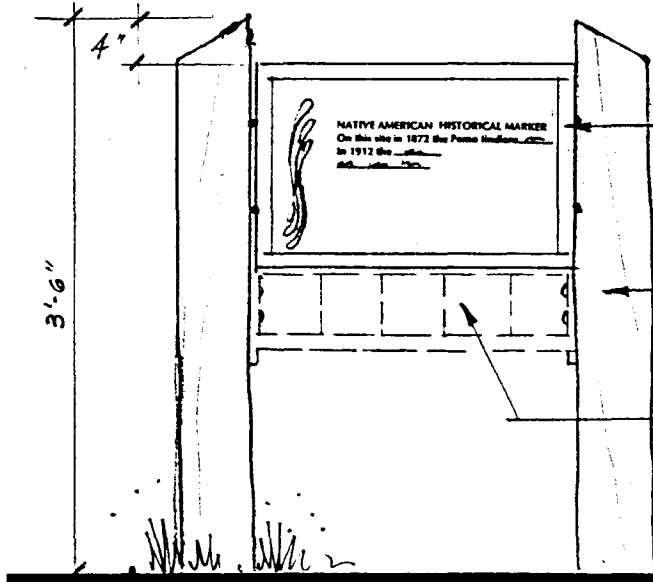

1" SQ. STL TUBE FRAME
 W/ BLACK FINISH

6X6 REDWOOD POST

INCORPORATE DIRECTIONAL
 SIGNS WHERE APPROPRIATE

FRONT ELEVATION

PATHWAY

CITY OF SANTA ROSA

Santa Rosa Creek Standards

Informational Signs

Scale:	Date:	
DWN	APPROVED	FILE NO.
CHK		STD.111A

Adopted _____, 1997
 by City Council Res. # _____

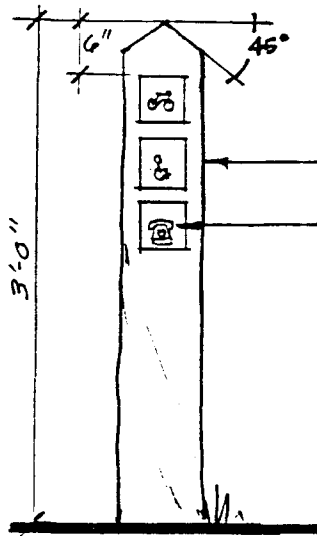

FRONT ELEVATION

6X6 REDWOOD POST

4" SQUARE STAMPED ALUMINUM SIGNS

• BLUE IMAGES ON BLACK BACKGROUND

• ROUTE WOOD TO ACCOMMODATE SIGN TO FIT FLUSH TO FACE OF POST

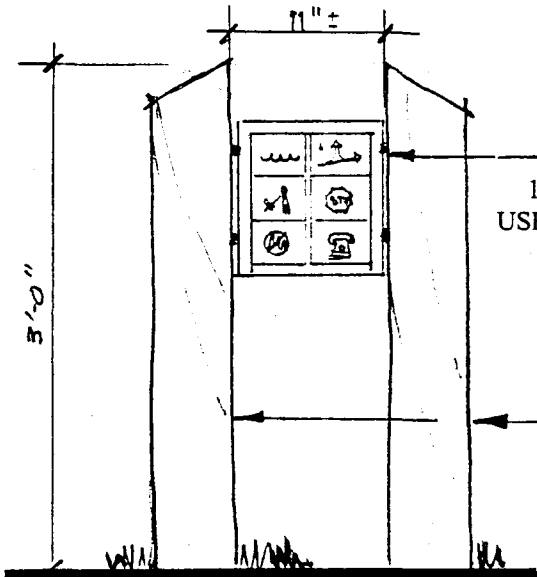

FRONT ELEVATION

COMBINE DIRECTIONAL SIGNS W/
1" SQ. STL TUBE FRAME W/ BLACK FINISH
USE WHEN 5 OR MORE SIGNS ARE NECESSARY

6X6 REDWOOD POST

CITY OF SANTA ROSA

Santa Rosa Creek Standards

Directional Signs

Scale:

Date:

Adopted _____, 1997
by City Council Res. # _____

DWN

APPROVED

FILE NO.

CHK

STD.111B

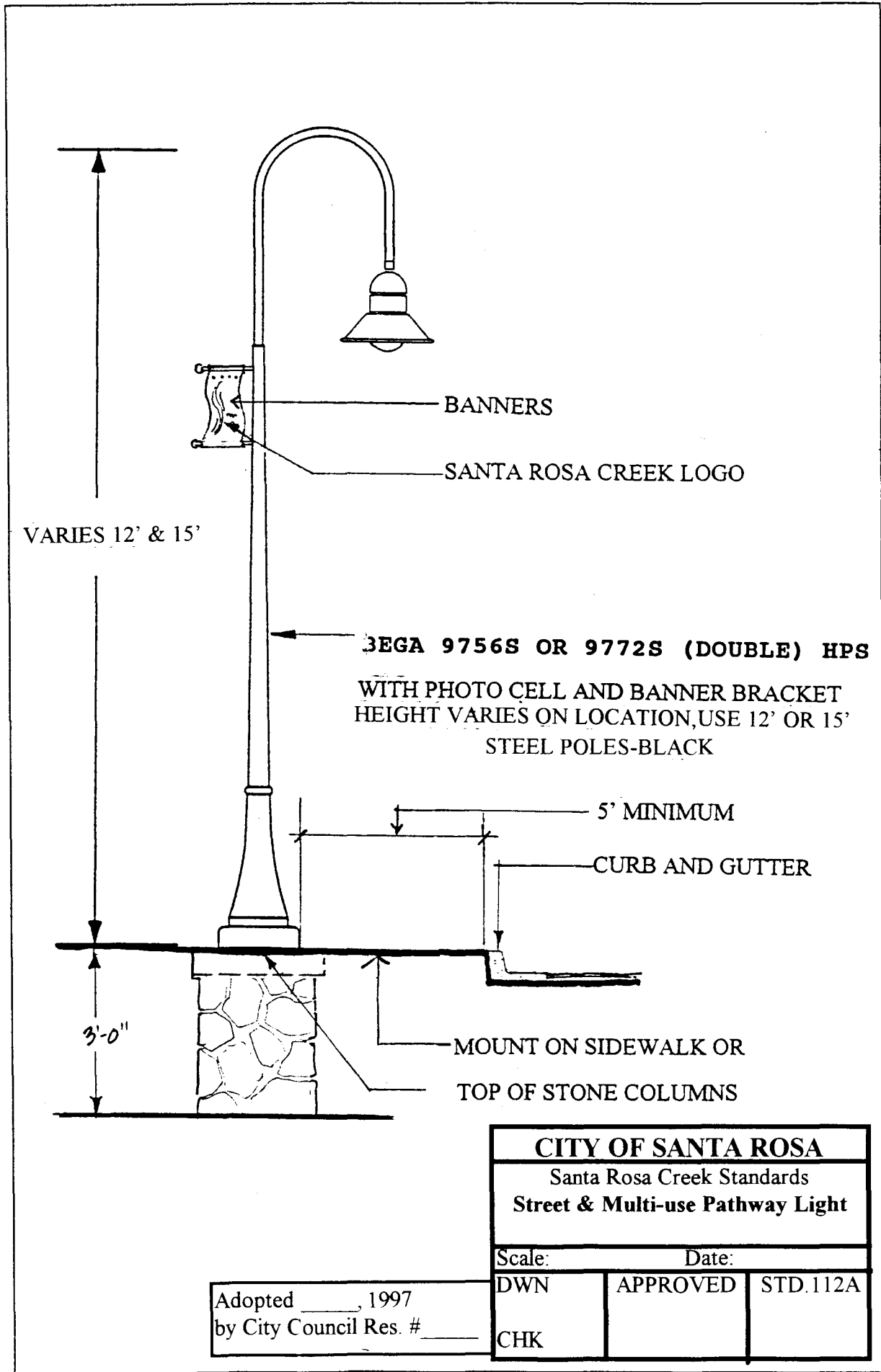

CITY OF SANTA ROSA

Santa Rosa Creek Standards
Street & Multi-use Pathway Light

Scale:		Date:	
DWN	APPROVED	STD.112A	
CHK			

Adopted _____, 1997
by City Council Res. # _____

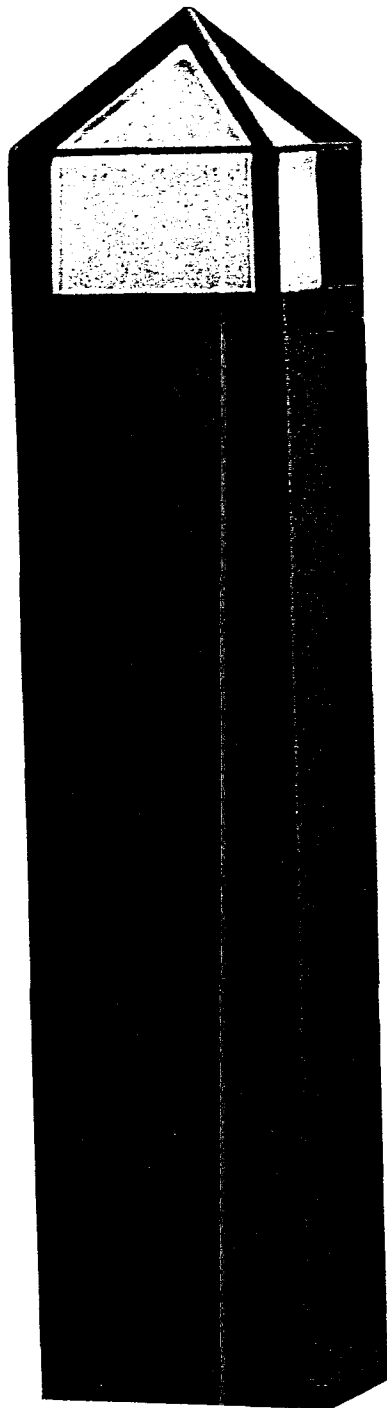

BEGA
BOLLARD LUMINAIRE
MODEL NO. 8516 S BLACK,
30" HIGH

CITY OF SANTA ROSA

Santa Rosa Creek Standards

Walkway Light

Scale:

Date:

DWN

APPROVED

STD.112B

CHK

Adopted _____, 1997
by City Council Res. # _____

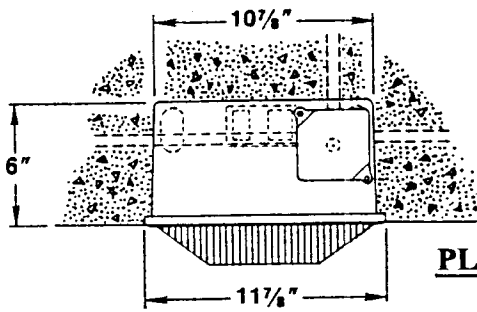

PLAN-SECTION

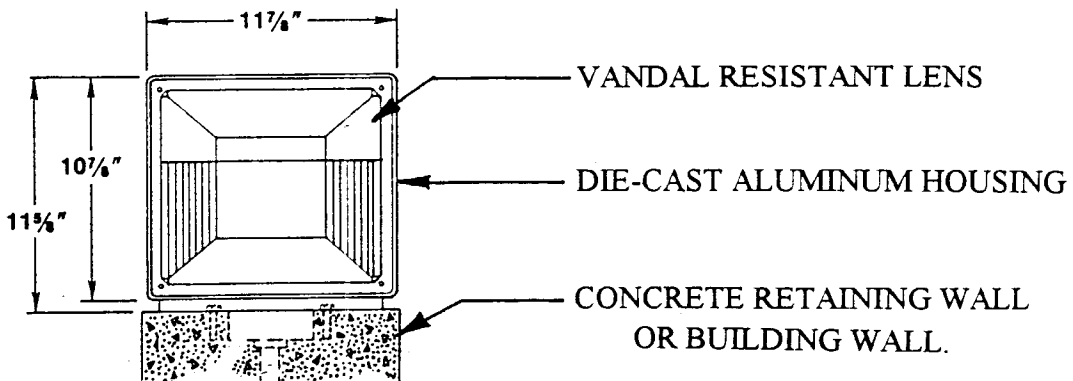

FRONT VIEW

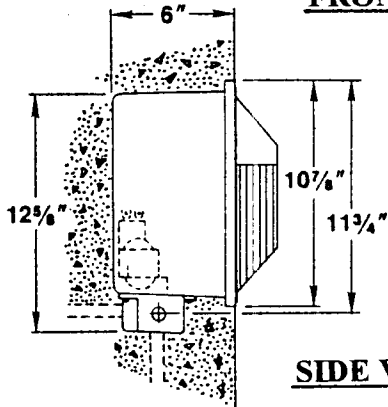

SIDE VIEW

MDL SERIES
 MDL SERIES RECESSED WALL OR NICHE LIGHT
 MODEL NO. MDL-2,3, OR 4-04-19-TPH-TCP

CITY OF SANTA ROSA		
Santa Rosa Creek Standards		
Recessed Wall Light		
Scale:	Date:	
DWN	APPROVED	STD.112C
CHK		

Adopted _____, 1997
 by City Council Res. # _____

BEGA

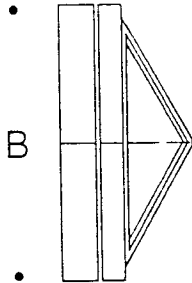
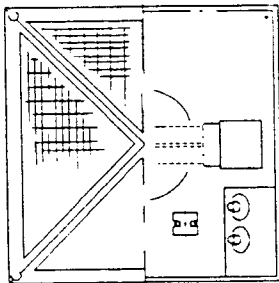
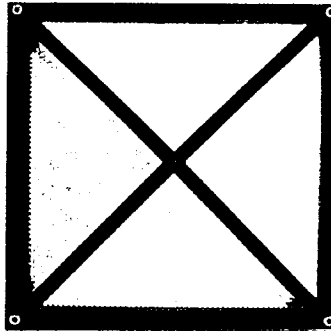

A

C

Square wall or ceiling mounted luminaires with die cast aluminum cross guard. injection molded polycarbonate plastic with internal optical structure. Captive socket head stainless steel screws.
Color: Black

Polycarbonate	Lamp	Lumen	A	B	C
2754P	1 13W PLC	860	8¼	8¼	4⅞
2756P	1 26W PLC	1800	10¼	10¼	5⅞

Adopted _____, 1997
by City Council Res. # _____

CITY OF SANTA ROSA		
Santa Rosa Creek Standards		
Wall Light		
Scale:		Date:
DWN	APPROVED	FILE NO.
CHK		STD.112D

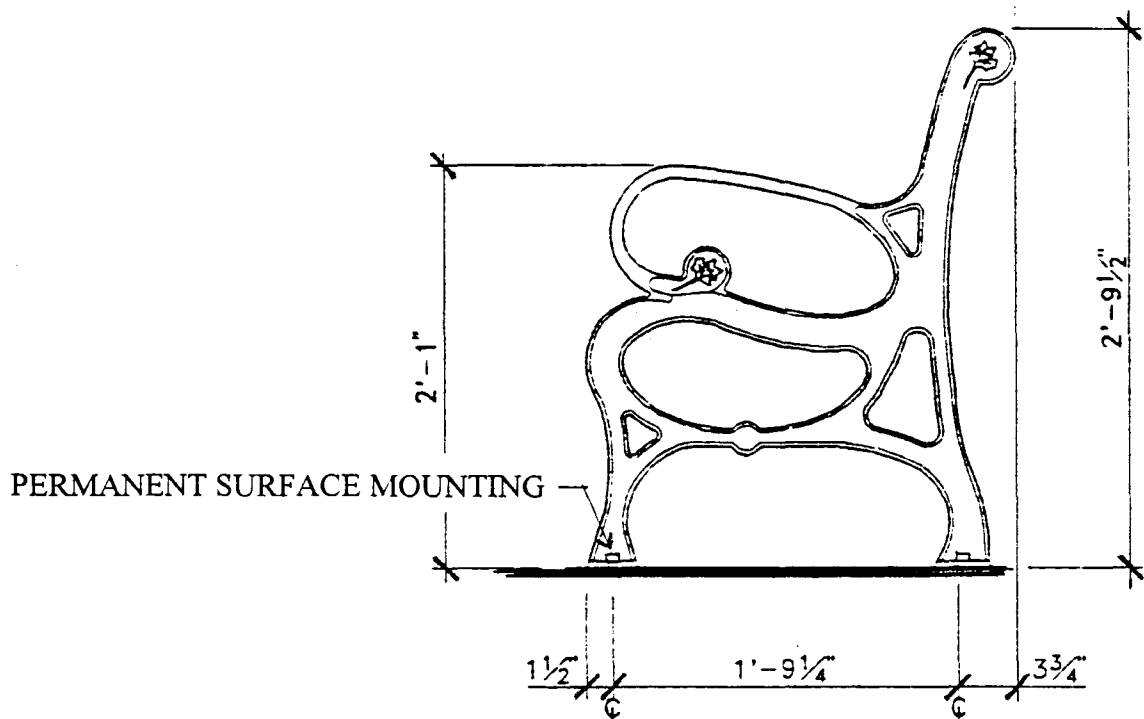

END VIEW

COLUMBIA CASCADE TIMBER FORM - RESTORATION #2118

COLOR: BLACK
 USE IN URBAN OR HISTORICALLY SIGNIFICANT AREAS

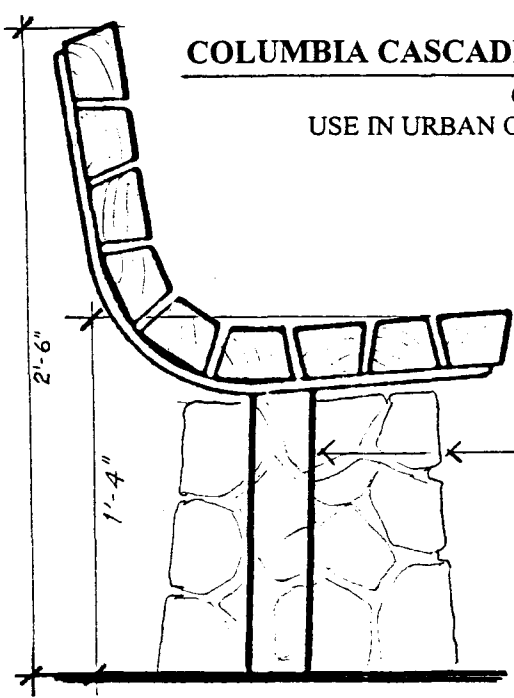

COLUMBIA CASCADE

← PROVIDE STL. POST MOUNT
 OR MASONRY STONE BASE

TIMBER FORM - GREENWAY #2140

USE IN RURAL AND NATURAL REACHES

CITY OF SANTA ROSA

Santa Rosa Creek Standards

Benches

Scale: _____ Date: _____

Adopted _____, 1997
 by City Council Res. # _____

DWN	APPROVED	FILE NO.
CHK		STD.113

METAL TREE GRATE

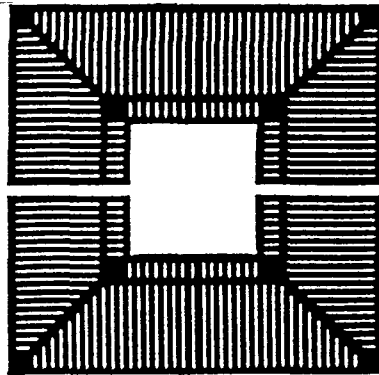

**IRONSMITH - ADA TREE GRATE
#M6058**

**#M6060 W/ LIGHT WELL
AND POLYCARBONATE COVER
• SQUARE TREE GRATE FRAME #M6000-F**

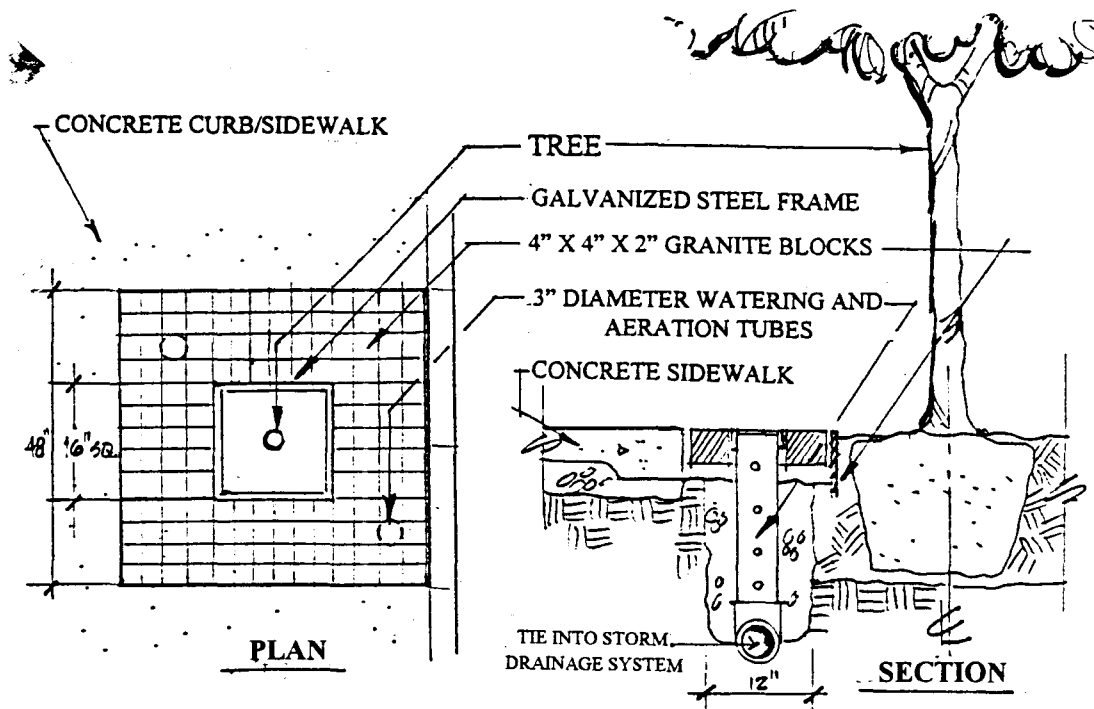

GRANITE COBBLED TREE WELLS

CITY OF SANTA ROSA
Santa Rosa Creek Standards
Tree Grates

Adopted _____, 1997
by City Council Res. # _____

Scale:	Date:	
DWN	APPROVED	FILE NO.
CHK		STD. 114

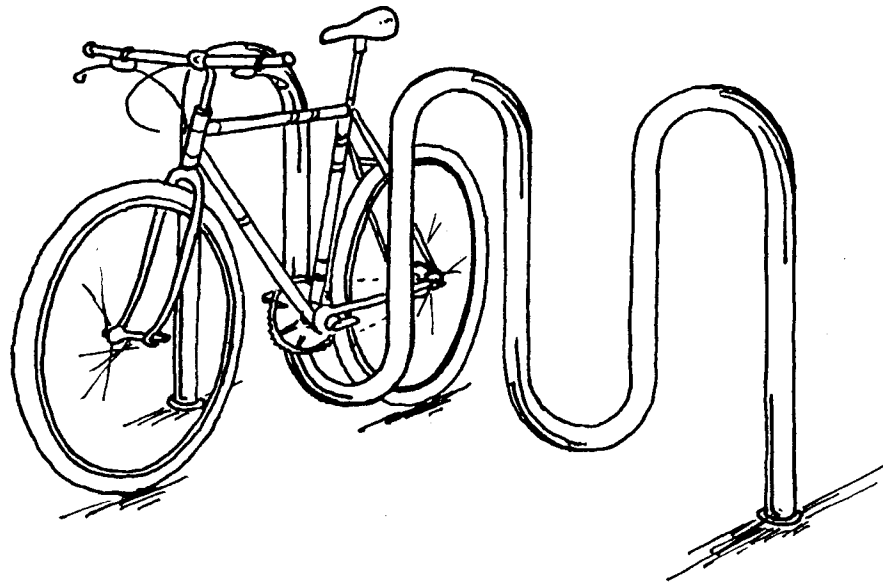

TIMBER FORM SUPER CYCLOOPS #2170 (LENGTH VARIES)

- PERMANENT EMBEDMENT OR SURFACE MOUNT ON EXISTING HARDSCAPE
DARK GREEN OR BLACK

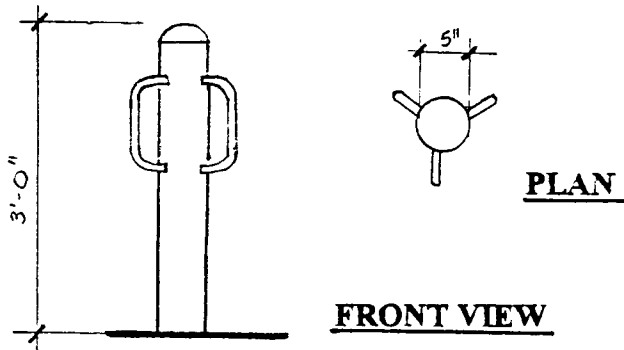

**COLUMBIA CASCADE
TIMBERFORM BOLLARD CYCLOOPS #2173**

- DARK GREEN OR BLACK

CITY OF SANTA ROSA

Santa Rosa Creek Standards

Bike Racks

Scale:

Date:

DWN

APPROVED

FILE NO.

CHK

STD.115

Adopted _____, 1997
by City Council Res. # _____

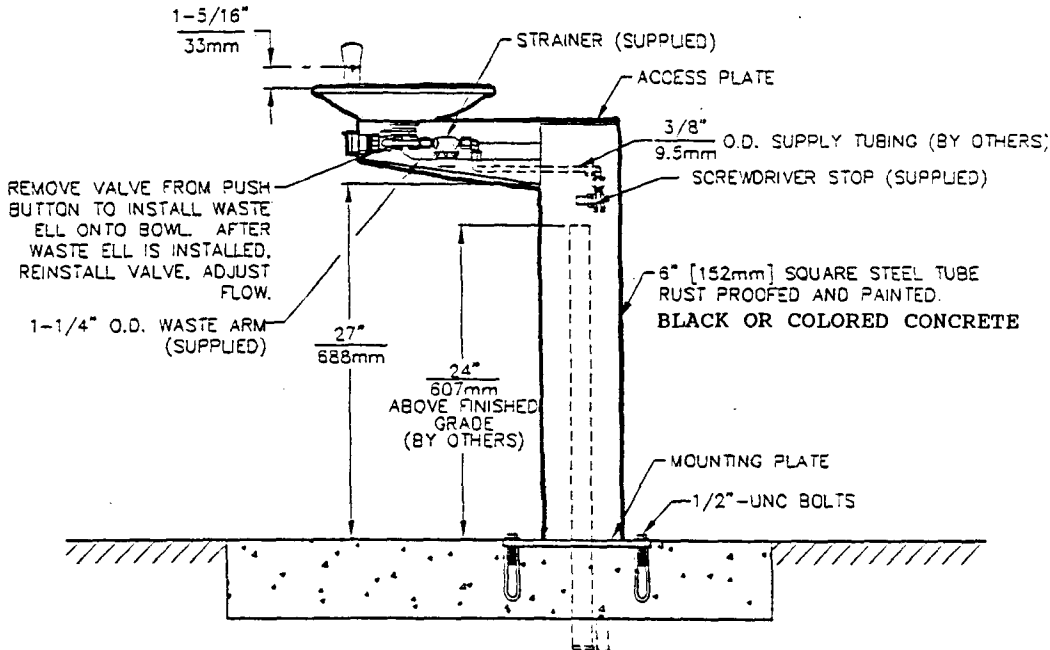
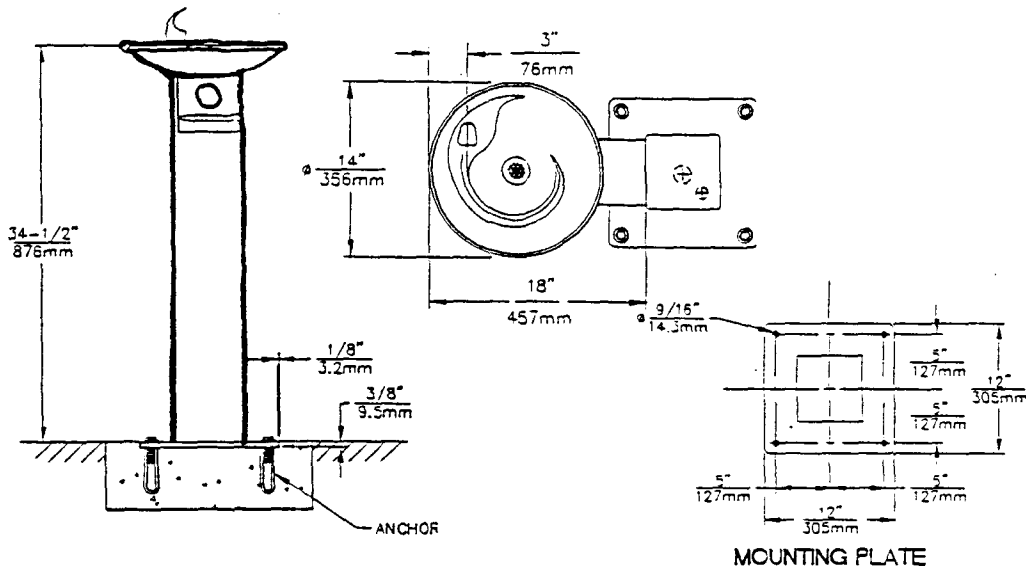

Haws Ornamental Stone

Model FMS76

Barrier Free Steel Pedestal Drinking Fountain

COLOR: BLACK WITH STAINLESS STEEL BOWL AND SAND TRAP

CITY OF SANTA ROSA		
Santa Rosa Creek Standards		
Drinking Fountains		
Scale:	Date:	
DWN	APPROVED	FILE NO.
CHK		STD.116

Adopted _____, 1997
by City Council Res. # _____

COLUMBIA CASCADE

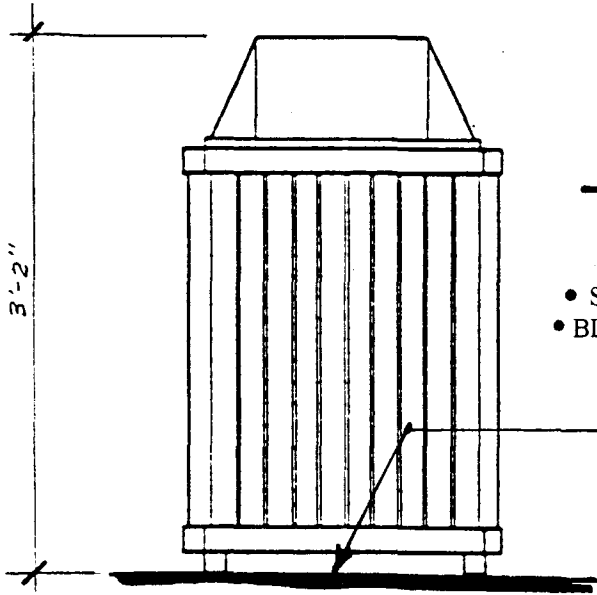

FEATURES

- PERMANENT MOUNT
- 36 GALLON STEEL LINER
- SIDE OPENING DOOR
- BLACK COLOR COATED STEEL FINISH

PERMANENT SURFACE

TIMBERFORM 'RESTORATION'

#2126-HT (MARINE TEAK)

FOR RURAL REACHES

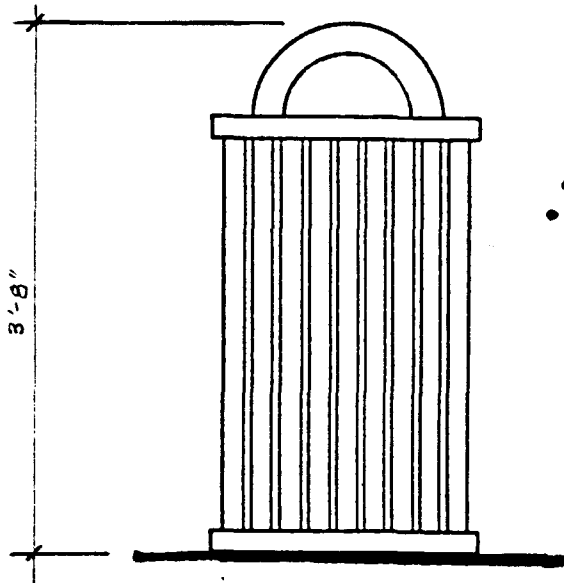

FEATURES

- PERMANENT MOUNT
- 36 GALLON STEEL LINER
- SIDE OPENING DOOR
- BLACK COLOR COATED STEEL FINISH

COLUMBIA CASCADE

TIMBERFORM 'MANOR'

#2834-DT

BLACK COLOR COATED STEEL

FOR URBAN REACHES

CITY OF SANTA ROSA

Santa Rosa Creek Standards

Trash Receptacle

Scale:

Date:

DWN

APPROVED

FILE NO.

CHK

STD.117

Adopted _____, 1997
by City Council Res. # _____



Santa Rosa
CREEK

CITY OF SANTA ROSA

Santa Rosa Creek Standards

Logo

Scale:

Date:

Adopted _____, 1997
by City Council Res. # _____

DWN

APPROVED

FILE NO.

CHK

STD. 118

Approves Design Concept Plan for the Pierson Reach of Santa Rosa Creek and the placement of the bike pathway

September 12, 2000

RESOLUTION NO. 24555

RESOLUTION OF THE COUNCIL OF THE CITY OF SANTA ROSA APPROVING THE DESIGN CONCEPT FOR THE PIERSON REACH CREEK RESTORATION AND BIKE PATHWAY ALONG SANTA ROSA CREEK FROM RAILROAD STREET TO PIERSON STREET

WHEREAS, the City of Santa Rosa desires to construct a bikeway from Railroad Street to Pierson Street, which will connect the Prince Memorial Greenway with the existing pathway at Pierson Street; and

WHEREAS, the City has applied for and been awarded federal and state funds for the design and construction of this bikeway; and

WHEREAS, the City entered into a contract with RRM Design Group for the concept design of the bike pathway; and

WHEREAS, the concept design of the bike pathway has been completed and has been reviewed and recommended by the City's Waterways Advisory Committee, the Railroad Square Property Owners, the Westside Neighborhood, and other interested parties.

NOW, THEREFORE, BE IT RESOLVED that the Council of the City of Santa Rosa approves the Design Concept for the Pierson Reach creek restoration plan and bike pathway to be constructed from Railroad Street to Pierson Street.

IN COUNCIL DULY PASSED this 12th day of September, 2000.



RRM DESIGN GROUP
San Luis Obispo • Oakdale • Felton

1701 South Figueroa Street • San Luis Obispo, California 93401 • 805.543.1794 • 805.543.4609 fax
131 South Second Avenue • Oakdale, California 95361 • 209.847.1794 • 209.847.2511 fax
Via Mapquest, 1/10/00 • 1/10/00 • 1/10/00 • 1/10/00 • 1/10/00 • 1/10/00 • 1/10/00 • 1/10/00 • 1/10/00 • 1/10/00
www.rrm-design.com

Neighborhood park/ tot-lot
Park access
Active park area

Creek access
Amphitheater
Elevated stage
Existing maintenance ramp

PIERSON PLAZA
Alcove seating
Shaded outdoor dining
Overlook with railing
Stair access to path
Alcove seating
Ramped path access



CONCEPTUAL PLAN

Pierson Reach



Demo building
Pierson Reach entry monument

6th Street

COMM. RETAIL

COMM. RETAIL REUSE

COMM. RETAIL REUSE

COMM. INDUSTRIAL

COMM. INDUSTRIAL

COMM. RETAIL or HOUSING REUSE

COMM. INDUSTRIAL

COMM. INDUSTRIAL

Commercial Office/ Retail

Future bike route

Wine & food center

4 Avenue parkway Bordering vineyard

R.R. DEPOT

Pedestrian railroad crossing/ bollards

Train car focal feature

4th Street

COMM. RETAIL

Round about Plaza/ fountain

PIERSON PLAZA ENTRY MONUMENT
Wine & food center entrance

COMMERCIAL OFFICE

Pierson Reach entry monument

Third Street access

MARRIOTT HOTEL

Future bike route

Promenade deck/
outdoor dining

Path route/ under Third Street

Revegetation areas

Roberts Avenue

Multi-use bridge

Point of connection -
Prince Memorial path



PIERSON PLAZA ENTRY MONUMENT

COMMERCIAL RETAIL

PROPOSED FUTURE HOTEL

OLIVE ST.

SECTION A-A
PIERSON STREET CROSSING
SCALE: 1" = 10'-0"



SECTION B-B
SCALE: 1" = 10'-0"

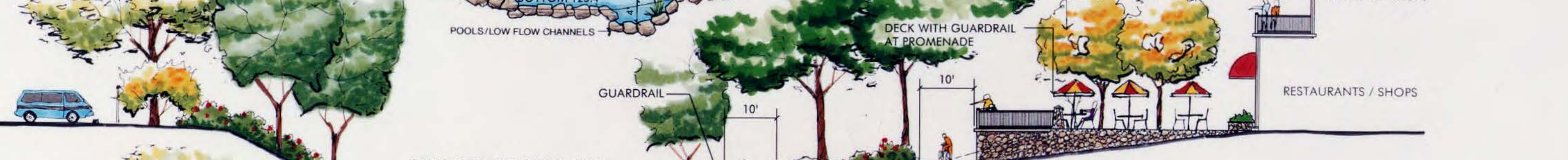

SECTION C-C
SCALE: 1" = 10'-0"



SECTION D-D
THIRD STREET CROSSING
SCALE: 1" = 10'-0"

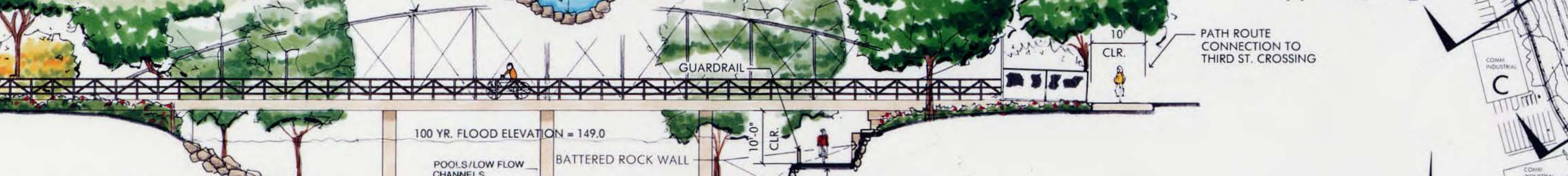

SECTION E-E
TRESTLE CROSSING
SCALE: 1" = 10'-0"

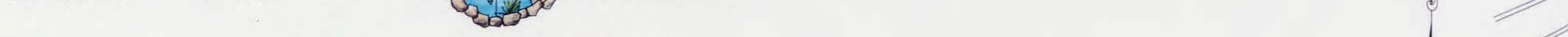

KEY MAP

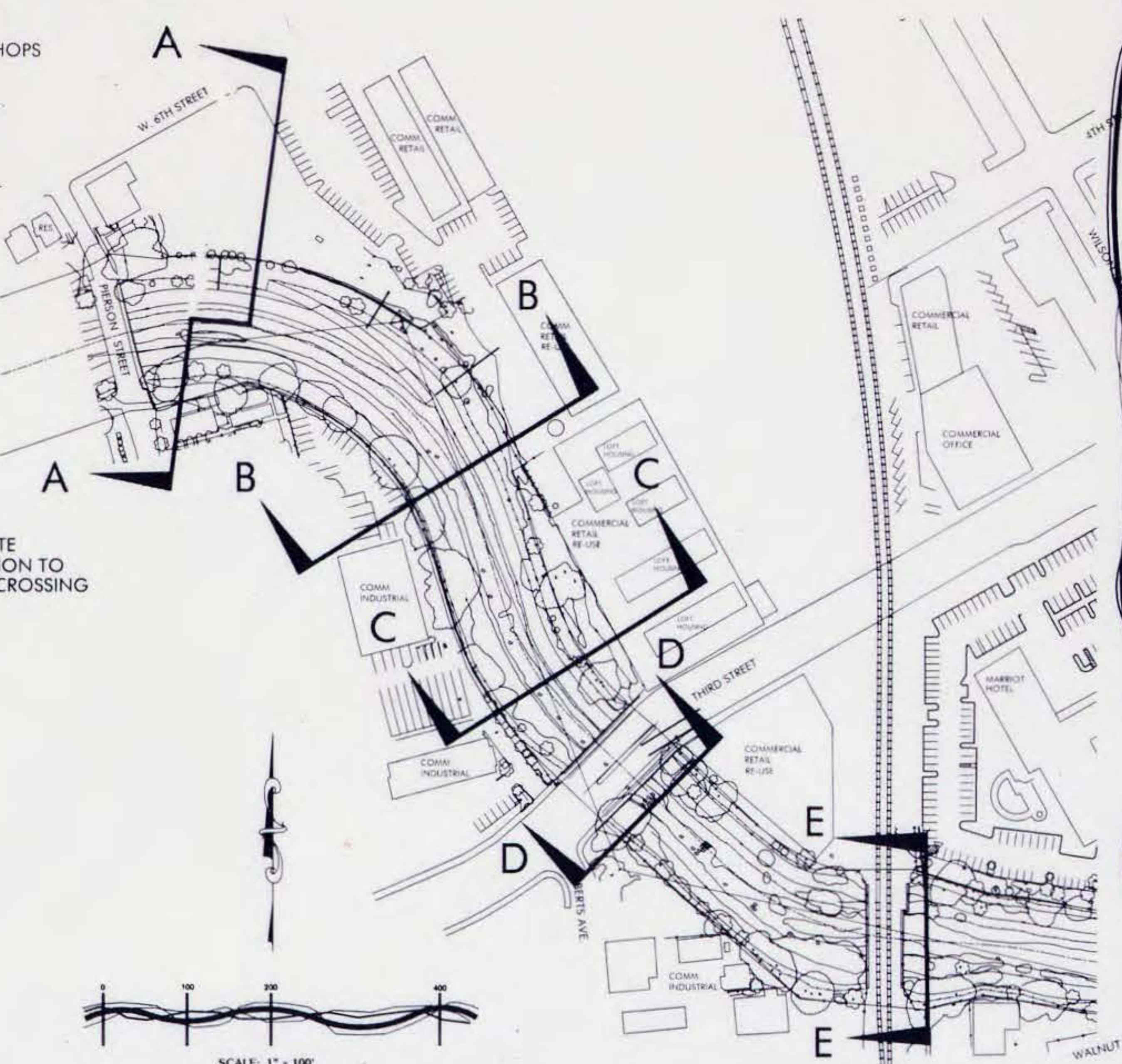

RRM DESIGN GROUP
San Luis Obispo • Oakdale • Felton
3701 South Higuera Street • San Luis Obispo, California 93401 • 805.543.1794 • 805.543.4699 fax
131 South Second Avenue • Oakdale, California 95361 • 209.847.1794 • 209.847.2311 fax
www.rrm-design.com

Pierson Reach

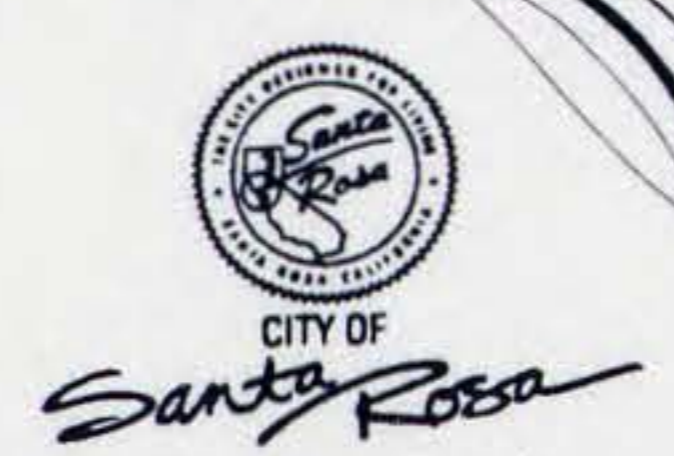

CREEK SECTIONS