

Exhibit A

SECOND AMENDED & RESTATED MEMORANDUM OF UNDERSTANDING

This Second Amended & Restated Memorandum of Understanding (the “**2021 MOU**”) is entered into on _____, 2021 (“**Effective Date**”) between the City of Santa Rosa, a municipal corporation (“**City**”) and De Nora UV Technologies, LLC (“**Supplier**”) for the supply of the Ultraviolet (“**UV**”) Light Disinfection System (“**System**” or “**UV System**”) for the Laguna Treatment Plant Disinfection Improvements Project (“**Project**”).

RECITALS

A. The City issued a Request for Proposal, Ultraviolet Light Disinfection Equipment Procurement, RFP 16-71 on September 22, 2016 (“**2016 RFP**”) and received a proposal from Calgon Carbon UV Technologies, LLC (“**Calgon**”) dated October 17, 2016 (“**2016 Proposal**”).

B. In October 2016, the City and Calgon entered into the original *Memorandum of Understanding* (the “**2016 MOU**”) related to the Project. The initial term for purchase under the 2016 MOU to avoid price escalation expired on May 17, 2018.

C. The City issued an Updated Price Request on December 24, 2019 (the “**2019 RFP**”), which modified the 2016 RFP. The 2019 RFP is attached hereto as Exhibit A.

D. The City received a revised proposal from Supplier dated March 23, 2020 (“**2020 Proposal**”). The 2020 Proposal is attached hereto as Exhibit B.

E. In March 2020, Calgon prepared an amended offer to the City, which resulted in an *Amended & Restated Memorandum of Understanding* between the City and Calgon dated August 10, 2020 (the “**2020 MOU**”). The term for purchase under the 2020 MOU to avoid price escalation is June 10, 2022, which is twenty-two (22) months from the date of approval by the City’s Board of Public Utilities (“**BPU**”).

F. Effective July 1, 2021, pursuant to *Securities Purchase Agreement* (the “**Purchase Agreement**”), Calgon’s name was changed to De Nora UV Technologies, LLC.

G. This 2021 MOU incorporates Supplier’s Best and Final Offer dated December 1, 2021 and attached hereto as Exhibit C, which Supplier provided to the City pursuant to Section 00200, Article 2 of the 2019 RFP and includes the Final Price (as defined below).

H. This 2021 MOU between the City and Supplier supersedes and replaces in full the 2020 MOU.

I. This 2021 MOU references other documents, each of which are considered integral parts of this 2021 MOU. All requirements embodied in the referenced documents are incorporated herein and made part of this 2021 MOU.

J. This 2021 MOU is intended to create a binding commitment between the Supplier and the City for acquisition of the UV System by City’s contractor from Supplier pursuant to the terms and conditions of this 2021 MOU.

AGREEMENT

ARTICLE 1 - DUTIES OF SUPPLIER

Supplier shall have the following duties under this 2021 MOU:

- (a) Prepare submittals for the City pursuant to the technical specifications and Appendix A Drawings (collectively referred to as the “**Technical Specifications**”) as set forth in the 2019 RFP (Exhibit A), the Proposal (Exhibit B), and this 2021 MOU. The initial submittals shall be delivered to the City within four (4) weeks after execution of an agreement for professional services with the City as identified in the 2019 RFP.
- (b) Provide coordination with the City in its completion through the final design of the UV System.
- (c) Provide supply bids for the System to the general contractors bidding on the Project that are identical to, and in accordance with, the 2019 RFP, the terms and conditions of this 2021 MOU and the 2020 Proposal, including Supplier’s Best and Final Offer (Exhibit C) provided pursuant to Section 00200, Article 2 of the 2019 RFP (Exhibit A). The terms and conditions offered by Suppliers to the general contractors shall be those customary in the California public works industry, to the extent the terms and conditions are not specifically addressed herein.
- (d) Deliver the UV System consistent with this 2021 MOU and provide approved submittals according to a schedule mutually agreed upon with the City’s contractor per Article 5, Section 4 (Delivery of the System) of this 2021 MOU.
- (e) Provide preliminary operation and maintenance (O&M) manuals to City and Contractor with storage and installation requirements prior to delivery of the UV System. Provide preliminary and final O&M manuals and training to the City for operation of the UV System in accordance with the Technical Specifications.
- (f) Meet other commercial warranty and risk management requirements set forth in the 2019 RFP and this 2021 MOU.

ARTICLE 2 • CITY OBLIGATIONS

City and Supplier shall have the following duties under this 2021 MOU:

- (a) Should the City undertake construction of the Project, it will competitively bid the public works contract in 2022 to include installation of the UV System at the Laguna Treatment Plant (“**LTP**” or “**Project Site**”), located at 4300 Llano Road, Santa Rosa, CA.
- (b) The City agrees that subject to the conditions below, it shall award the public works construction contract to the lowest responsible and responsive bidder consistent with California law and, to the extent applicable, the City Code.
- (c) To the extent permitted by applicable state and local law, the City agrees to complete design of the Project so as to accommodate the Supplier's UV System and shall require City’s contractor to purchase and install Supplier's UV System. The City shall further require that City’s contractor obtain the UV System from Supplier pursuant to the price and payment terms set forth in this 2021 MOU.

- (d) The obligation, as set forth in the preceding paragraph, to obtain the UV System from Supplier shall be and is hereby expressly conditioned upon the City's award of the construction contract for the Project, and the favorable result of any legal challenge to this process which could result in a court order or judgment preventing or otherwise delaying the City from either executing the construction contract for the Project or requiring City's contractor to install Supplier's UV System. If City fails to proceed with the Project, is prevented or delayed from entering into the construction contract or is prevented by legal proceedings from designating Supplier's UV System for inclusion in City's Project, City shall not be liable to Supplier for any costs, expenses, or damages of any kind or nature, including, but not limited to restocking, proposal preparation and contracting costs, or loss of prospective profit.

ARTICLE 3 • BEST AND FINAL OFFER; FINAL PRICE

- (a) The UV System shall be manufactured, insured, and delivered for Supplier's Best and Final Offer for a sum not-to-exceed \$5,923,491.28 dollars in US currency ("**Final Price**"). This Best and Final Price includes all payments for the Supplier's costs of any kind.
- (i) The Final Price does not include California and/or local sales tax. California Sales Tax and/or local sales taxes will be added to the items to which they apply at the rate prevailing at the time each applicable invoice is prepared and sent to the contractor.
- (ii) The Final Price does not include \$86,000 in design work performed by Supplier, as described in Article 1(a) and 1(b) of this 2021 MOU, and more particularly in a separate Professional Services Agreement between City and Supplier to cover design assistance to the City.
- (iii) The Final Price set forth in Supplier's Best and Final Offer (attached hereto as Exhibit C) supersedes and replaces all prior prices and offers from Supplier.
- (iv) The Final Price utilizes steel prices as referenced in the Best and Final Offer (Exhibit C). Where the price of steel at the time of procurement by City's contractor results in equipment costs less than the prices outlined in the Best and Final Offer, Supplier agrees to reduce the Final Price of the UV System by the difference between the Best and Final Offer price and the resulting procurement price.
- (b) The Final Price set forth herein includes the cost of shipping F.O.B. to the Project Site (LTP). City's contractor will not accept C.O.D. shipments. Supplier shall be responsible for payment of all charges for handling, shipping, packaging, wrapping, bags, container, boxing, crating, labeling, customs and duties, insurance and other related matters.
- (c) Supplier agrees to offer all bidders on the Project the UV System in accordance with this 2021 MOU, which includes Supplier's Best and Final Offer (Exhibit A) provided by Supplier pursuant to Section 00200, Article 2 of the 2019 RFP and as more specifically set forth in the specifications and approved Appendix A Drawings and without additional terms and conditions inconsistent with this 2021 MOU. Any such additional terms and conditions offered to contractors, not inconsistent with the terms of this 2021 MOU, shall be those customary to the public works industry in California and in Santa Rosa, and offered at no additional cost.

ARTICLE 4 • PAYMENT TERMS

The City agrees to include the Final Price for the UV System and payment terms ("Milestones") in

substantially the following form in its invitations for bids and construction contract for the Project:

1. *Ten percent (10%) upon order acceptance by Supplier.*
2. *Ten percent (10%) upon engineering submittals to City's contractor.*
3. *Twenty percent (20%) based on procurement of main materials by Supplier.*
4. *Forty percent (40%) at upon delivery of UV System per Incoterms set forth in this 2021 MOU.*
5. *Fifteen percent (15%) upon submission of final documentation by Supplier*
6. *Five Percent (5%) upon successful completion of performance testing, approval of O&M manual by CITY, training of CITY's employees and upon completion of the UV System and final acceptance of the UV System by the CITY, said acceptance not to exceed 1 year from equipment delivery.*

The partial payments set forth above shall be due only upon full and complete performance of each prior Milestone listed above.

Any late payments from Contractor shall be subject to interest on the unpaid balance at the rate of one and one-half (1-1/2%) percent per month or the maximum rate permitted by applicable law, whichever is less.

ARTICLE 5 - TERMS AND CONDITIONS

1. Inspection and Performance Testing: City's contractor will review accelerometer on the delivery truck, and visually inspect shipment(s) from Supplier upon receipt at Project site to determine whether they conform to the requirements of this 2021 MOU. Notwithstanding these provisions for inspection, Supplier acknowledges that the UV System is not reasonably subject to mere visual inspections to ascertain whether the equipment fully conforms to the applicable specifications and that testing after installation is required prior to final acceptance of the UV System. City's contractor shall be required to schedule performance testing per the Technical Specifications with the assistance of the Supplier.
2. Operations Manual and Training: Supplier shall be responsible to provide an operations and maintenance manual and training to the City's employees as set forth in the Technical Specifications. All costs associated with provision of the operations and maintenance manual and employee training is included in the price set forth above.
3. Price Escalation: The Final Price set forth in Supplier's Best and Final Offer (attached to this 2021 MOU as Exhibit C) shall remain in effect and is not subject to price escalation for any reason until December 31, 2022; By way of illustration but not of limitation, price escalation beyond the Final Price is not permitted (i) due to any changes in labor costs and/or material costs, (ii) changes in international tariffs applicable to Supplier, (iii) supply chain issues or delays; and/or (iv) other similar economic issues or conditions that impact Supplier's costs. The City may seek to extend this 2021 MOU subject to appropriate BPU approval if there is a delay in the bidding and/or award of the construction project.
4. Delivery of the System: Delivery of UV System will be FOB LTP. Supplier shall have the UV System ready to ship at the time agreed upon with the City's contractor and delivery of the UV System shall be coordinated between Supplier and the City's contractor so as to avoid storage and/or re-shipping of the UV System.
5. Warranty: Supplier expressly warrants that the UV System shall conform to all Technical

Specifications and final design. All UV System parts and components shall be new and of good merchantable quality, free from material defects of workmanship and fit for the purpose specified. For purposes of this warranty, any parts not meeting the foregoing quality, upon reasonable analysis by City, shall be deemed defective. Supplier shall provide warranties on all individual components of the UV System and the UV System as a whole as set forth in the Technical Specifications. The foregoing warranty provisions shall also be applicable to any other equipment or software supplied to Supplier by a third-party entity and provided to City's contractor pursuant to this 2021 MOU. Any warranties provided by third party equipment or software supplier shall be assigned to the City after final acceptance as defined in the Technical Specifications. Each warranty described in this term shall be assignable, and no limitation or restriction in the warranty shall result from the assignment. Any modification, storage; or use (collectively, the "Use") of the UV System that is adverse, material and not in accordance with City Technical Specifications or Supplier's documentation shall void warranty obligations of Supplier related to such UV System to the extent of such adverse and material Use.

6. Liens, Claims And Encumbrances: Supplier warrants and represents that the UV System and any other equipment or software when delivered will be free and clear of all liens, claims, encumbrances and infringements of any patents, trademarks, copyrights or franchise rights.
7. Independent Contractor: Supplier, and Supplier's employees or persons under contract to Supplier in the performance of services on this 2021 MOU, including services provided on City property, shall perform work as independent contractors. Supplier shall provide insurance to cover its work and its employees as required by the City and/or City's contractor. Further, neither party to this 2021 MOU is the agent or legal representative of the other party for any purpose, nor shall the actions of either party under this 2021 MOU create a partnership, joint venture, or relationship of principal and agent between the Parties.
8. Indemnification: Supplier agrees to indemnify, protect, hold harmless and defend City and their officers, agents, employees, volunteers, and boards, from any and all claims or liabilities, including but not limited to claims or liabilities arising from any liability imposed for injury, as defined by California Government Code Section 810.8, whether arising before or after completion of the work hereunder, or in any manner, directly or indirectly caused, claimed occasioned or contributed to, by reason of any negligent act or omission or willful misconduct of Supplier, excepting for claims or liabilities arising from active negligence of City. Supplier shall also indemnify, protect, hold harmless and defend City and/or City's contractor for claims or liabilities arising by reason of claimed infringements of any patents, trademarks, copyrights or franchise rights, in connection with or incident to or arising out of the performance of this 2021 MOU, unless the alleged infringement occurs as a direct result of any alteration or modification to the product or the use of the System in combination with the products or services of any party other than Supplier; provided, however, that Supplier agrees to indemnify, protect, hold harmless and defend City and/or City's contractor for claims or liabilities where alterations, modifications or use of the System is directed, recommended, or approved by the Supplier. Supplier agrees to maintain insurance as set forth in Exhibit D until all performance testing and final acceptance of the UV System is completed by City. Notwithstanding any other terms in this 2021 MOU, the total aggregate liability of Supplier for any and all causes of action arising out of this 2021 MOU, shall not exceed all available insurance proceeds plus two (2) times the Final Price in this 2021 MOU.
9. Assignment: Supplier shall not assign any of its responsibilities under this 2021 MOU, and no such assignment will be binding upon City or City's contractor unless such assignment has had prior written approval of City, which approval shall be solely within the discretion of City and shall not be unreasonably withheld.

10. Jurisdiction: This 2021 MOU shall be administered and interpreted under the laws of the State of California, including but not limited to the Uniform Commercial Code, without regard to the conflict of law's provisions thereof. The United Nations Convention on the International Sale of Products will not apply. The jurisdiction for any litigation arising from this 2021 MOU shall be in the state of California, and its venue shall be in the location in or nearest to the County of Sonoma.
11. Modifications: No modification to this 2021 MOU, nor any waiver of any rights, shall be effective unless agreed to in writing by both Parties.
12. Liquidated Damages: The City's contractor may include liquidated damage penalties in its agreement with Supplier to the extent that the same are required of the City's contractor. Such damages should be applicable only if the delay giving rise to the liquidated damages is related to Supplier's failure to deliver the UV System within the conditions set forth in Article 5 Section 4 of this 2021 MOU, failure to support the startup of the UV System, failure of the UV System during the startup where any such failures result in a delay to the Project, or delivery of a UV System that does not conform to or operate consistent with the requirements of the Technical Specifications, Final Submittal and/or this 2021 MOU and remains uncured by Supplier for an unreasonable period. The amount of such damages shall not exceed ten (10) percent of the Best and Final Price in this 2021 MOU.
13. Counterparts and Electronic Signatures. This 2021 MOU and future documents relating thereto may be executed in two or more counterparts, each of which will be deemed an original and all of which together constitute one agreement. Counterparts and/or signatures delivered by facsimile, pdf or City-approved electronic means have the same force and effect as the use of a manual signature. Both City and Consultant wish to permit this 2021 MOU and future documents relating thereto to be electronically signed in accordance with applicable federal and California law. Either party to this 2021 MOU may revoke its permission to use electronic signatures at any time for future documents by providing notice pursuant to the 2021 MOU. The Parties agree that electronic signatures, by their respective signatories are intended to authenticate such signatures and to give rise to a valid, enforceable, and fully effective 2021 MOU. The City reserves the right to reject any digital signature that cannot be positively verified by the City as an authentic electronic signature.
14. Notices: All notices under this 2021 MOU shall be in writing and shall be considered delivered and effective on the earlier of actual receipt of (i) the business day following transmission if sent by email, or (ii) one (1) business day after dispatch if sent by private overnight carrier (e.g., Federal Express); or (iii) five (5) business days after posting if sent by certified mail. Notice shall be sent to the persons listed below. Each party has the right to change their key personnel and must do so in writing. Change of personnel must be mutually acceptable unless the listed person is no longer employed by the party.

Supplier:

Contact Name: Kris Sticinski

Address: 2000 McClaren Woods Dr., Coraopolis, PA 15108

Phone: 724-218-7001

E-mail: kris.sticinski@denora.com

with a copy to: Legal Department

Address: 7590 Discovery Lane, Concord OH 44077

E-mail: LegalDepartment.DNT@denora.com

City of Santa Rosa:

Contact: City Project Manager/Representative
Name: Jason Roberts, Supervising Engineer
Address: 69 Stony Circle, Santa Rosa, CA 95401
Phone: (707) 543-3857
Fax: (707) 543-4281
E-mail:

with Copies to: City Attorney's Office
Address: 100 Santa Rosa Ave, Room 8, Santa Rosa, CA 95404
Phone: (707) 543-3040
Fax: (707) 543-3055
E-mail: caoffice@srcity.org

with copies to: Construction Manager:
Contact: Chris Davenport, Senior Project Manager/VP, Psomas
Address: 1660 Olympic Boulevard, Suite 300, Walnut Creek CA, 94596
Phone: 925-933-2300
E-mail: chris.davenport@psomas.com

15. Severability: If any portion of this 2021 MOU is held invalid, with the exception of the Parties agree that such invalidity shall not affect the validity of the remaining portions of this 2021 MOU, and the Parties shall seek in good faith to agree to substitute for the invalid provision a valid provision that most closely approximates its terms.
16. Entire Agreement: This 2021 MOU, along with the incorporated Exhibits, supersedes all oral or written negotiations, conversations or discussions between the Parties and contains the entire understanding and agreement of the Parties relating to this subject matter.
17. Order of Precedence. In the event of a conflict between any of the foregoing reference documents, the order of precedence shall be as follows: 2021 MOU, Best and Final Offer, Final Submittal, 2019 RFP, 2020 Proposal.

[SIGNATURES APPEAR ON FOLLOWING PAGE]

///

///

This 2021 MOU is hereby entered into between the City and the Supplier. By signing this 2021 MOU, each of the undersigned asserts that they have the respective authority to enter into this agreement on behalf of the respective party for whom they are signing.

Executed as of the Effective Date.

DE NORA UV TECHNOLOGIES, LLC.,
a Delaware Limited Liability Corporation

CITY OF SANTA ROSA,
a Municipal corporation

By: _____

By: _____

Name: _____

Title: _____

Title: _____

Approved as to form:

By: _____

City Attorney's Office

Name: _____

Title: _____

ATTEST:

City BT Cert # _____

Exhibits

Exhibit A – 2019 RFP

Exhibit B – 2020 Proposal

Exhibit C – Supplier's Best and Final Offer Letter dated December 1, 2021

Exhibit D - Insurance

EXHIBIT

A1

REQUEST FOR PROPOSAL



REQUEST FOR PROPOSALS

16-71

ULTRAVIOLET LIGHT DISINFECTION EQUIPMENT SYSTEM

DATE ISSUED

SEPTEMBER 22, 2016

PROPOSAL SUBMITTAL DUE DATE

OCTOBER 17, 2016 (AD1)

BY 4:00 P.M.

UPDATED PRICE REQUEST

DECEMBER 2019

TO

BRANDALYN TRAMEL

PURCHASING AGENT

CITY OF SANTA ROSA PURCHASING OFFICE

635 FIRST ST., 2ND FLOOR

SANTA ROSA, CA 95404

707-543-3706 VOICE

Btramel@srcity.org

ULTRAVIOLET (UV) LIGHT DISINFECTION EQUIPMENT SYSTEM

TABLE OF CONTENTS

DIVISION 00 – PROPOSAL REQUIREMENTS, CONTRACT FORMS, AND CONDITIONS OF THE PROPOSAL

SECTION NO.	TITLE
00200 Updated	BACKGROUND AND GENERAL INFORMATION TO SUPPLIERS
00300	REQUEST FOR PROPOSAL REQUIREMENTS

TECHNICAL SPECIFICATIONS

DIVISION 01 – GENERAL REQUIREMENTS

SECTION NO.	TITLE
01110	SUMMARY OF WORK
01330	SUBMITTAL PROCEDURES
01410	REGULATORY REQUIREMENTS
01450	QUALITY CONTROL
01600	PRODUCT REQUIREMENTS
01610	PROJECT DESIGN CRITERIA
01612	SEISMIC DESIGN CRITERIA
01756	COMMISSIONING AND PROCESS START-UP
01782	OPERATION AND MAINTENANCE DATA

DIVISION 11 - EQUIPMENT

SECTION NO.	TITLE
11289 Updated	LOW-PRESSURE, HIGH-OUTPUT ULTRAVIOLET DISINFECTION SYSTEM

DIVISION 16 - ELECTRICAL

SECTION NO.	TITLE
16050	COMMON WORK RESULTS FOR ELECTRICAL
16123	600-VOLT OR LESS WIRES AND CABLES
16150	LOW VOLTAGE WIRE CONNECTIONS
16494	LOW VOLTAGE FUSES

DIVISION 17 - INSTRUMENTATION AND CONTROLS

SECTION NO.	TITLE
17055	PACKAGED CONTROL SYSTEM

PROPOSAL FORMS

00410 PROPOSAL FORM **Updated**

00410 PROPOSAL FORM September 2016 Proposal

SAMPLE MEMORANDUM OF UNDERSTANDING

00525 MEMORANDUM OF UNDERSTANDING (MOU) **Updated**

00525 MEMORANDUM OF UNDERSTANDING (MOU) Executed Original

SAMPLE PROFESSIONAL SERVICES AGREEMENT

00550 PROFESSIONAL SERVICES AGREEMENT

APPENDIX A - DRAWINGS (Separate Document)

SECTION 00200

BACKGROUND AND GENERAL INFORMATION TO SUPPLIERS

ARTICLE 1 - GENERAL INTRODUCTION

The purpose of this Request for Proposal (RFP) is to accept qualifications and proposals from interested parties seeking to furnish all components required to provide a complete operable Low Pressure, High Output Ultraviolet Disinfection Equipment Systems (System), associated work items and spare parts for the CITY of Santa Rosa's (CITY) Laguna Treatment Plant (LTP). This RFP will provide the means to select a System, standardize to that System, establish and hold pricing through a Memorandum of Understanding (MOU) for the selected System that will allow CITY to brand name specify the System in a construction contract CITY will award in 2017 to a general installation contractor (Contractor or Installation Contractor) through a separate Invitation to Bid process and provide for a pricing for a purchase order facilitated by the CITY for spare parts which will be managed directly by the CITY. Proposals for the System shall be based on the Technical Specifications and attached drawings contained in this RFP, which set forth the required specifications for the equipment to be provided as well as other work associated with the incorporation of the equipment into the System at the LTP.

Upon completion of the RFP process CITY expects the following:

- The CITY will have selected the Supplier of a System and will be able to work with the Supplier to standardize the proposed project at the LTP to that System.
- The selected Supplier will be prepared to participate with the CITY in a design workshop as described in the Technical Specifications Section 112898. Minor modifications to the System proposed under this RFP will be negotiated following the design workshop.
- The CITY will have establish fixed and known cost of the System through the execution of a Memorandum of Understanding with the CITY in generally the form set forth at Section 00525 of this RFP (MOU).
- The Supplier shall guarantee the System pricing for up to 18 months from the date of CITY Board of Public Utilities (BPU) approval of the MOU, and offer that pricing to Contractor.
- Supplier shall provide costs associated with design workshops and other coordination as to details of final System design and installation as specified in the Technical Specification.
- Supplier shall establish future maintenance and operating cost for a given time period so that CITY may better plan expenses associated with the possible purchase order for additional System parts or spares.

The RFP will create an equal basis for selection of the System and replacement parts/spares based on the criteria for selection as outlined within this solicitation (Article 9).

The CITY will enter into an agreement with the Supplier for shop drawings and design assistance referred to herein as the design assistance, through a professional services agreement in generally the form set forth at Section 05500 of this RFP. The Supplier shall guarantee the equipment pricing for up to 18 months from the date of CITY BPU approval of the MOU. Following the design workshop, the CITY and Supplier will negotiate a Best and Final Offer and the MOU will be amended to incorporate that final price and it will be included in the installation bid documents. Once a general installation Contractor is awarded, the Contractor will purchase the equipment on behalf of CITY at pricing established within the MOU, as amended to include the Best and Final Offer. The Contractor will be responsible for accepting, installing, and assisting with testing the System. The Contractor will be responsible for the installation of the concrete channels and appurtenances that will house the System, and for providing necessary power infrastructure.

For the purpose of this RFP the following definitions shall apply:

- Supplier means person or entity submitting Proposal under this Request for Proposal to furnish a complete UV Disinfection system including any required cleaning system, spare parts and special tools, shop drawings, assistance during design, freight to Santa Rosa LTP, supervision of installation, testing, training, commissioning, warranty, and follow-up support services.
- Contractor or Installation Contractor means person or entity that will be awarded an installation construction contract in 2017 through a separate Invitation to Bid process with CITY to install the System selected under this RFP.
- Qualifications means to provide evidence that demonstrates Supplier is suitable to satisfactorily provide the equipment and services in conformance with the Procurement Documents. Supplier is required to submit written evidence on financial data, previous experience, and other such data for performance of the Work covered by the Procurement Documents.
- Procurement Documents - The Procurement Documents as listed in the Request for Proposal for Ultraviolet (UV) Light Disinfection Equipment Proposal, RFP 16-71 include: Section 0200 Proposal Background and General Information to Suppliers, Section 00300 – Request for Proposal Requirements, , Technical Specifications, , Section 00410 – Proposal Form, Section 00525 – Memorandum of Understanding (MOU), Section 05500 Form of Professional Services Agreement including insurance requirements, and Attachment 1 – Drawings.
- System means a complete operable Low Pressure, High Output Ultraviolet Disinfection Equipment Systems.
- Project means Laguna Treatment Plant Disinfection Improvements Project, of which the System will be a part.
- The Work shall have the meaning prescribed in Section 01110, Part 1.02 of the Technical Specifications.

- Addenda means a document or information attached or added to the RFP to clarify, modify, or support the information in the original RFP. Any Addendum issued by CITY during the RFP process shall be considered part of the Procurement Documents.
- Best and Final Offer means negotiated pricing submitted to the CITY on an updated Document 00410 - Proposal Form following the design assistance, which may result in minor modifications to the System.
- CITY means CITY of Santa Rosa, a municipal corporation in the state of California.

ARTICLE 2 - PROPOSAL PROVISIONS

The Proposal submitted in response to this RFP will be evaluated by the CITY for compliance with the requirements and criteria specified in this RFP. The CITY will select the System and associated work that complies with the requirements in accordance with the process delineated in Article 9 of this RFP.

Following selection under this RFP, the Supplier shall provide submittals and design assistance including participation in a design workshop, as specified in Section 11289, Part 2.03 of the Technical Specifications with CITY and their project team members to coordinate details for the Project, including but not limited to installation, operation, and maintenance details System as part of the overall Project. The CITY will compensate for Supplier for participation in the design workshop as defined in costs provided for in Proposal (line 3 of cost Proposal Form 0410). Minor modifications to the System identified during the design workshop shall be provided by the Supplier for consideration and CITY acceptance based on the needs of the CITY and the Project. The cost for these minor modifications shall be negotiated with CITY by the Supplier. The final negotiated price for the System will be included in a Best and Final Offer, which will be incorporated into the MOU by amendment and into the future Project bid documents. It is intended that price negotiations include process units, controls, and ancillary system components relative to installations.

ESTIMATED SCHEDULE

The RFP will be governed by the following schedule, but may be subject to change:

Release RFP	September 22, 2016
Question and Answer Period Due	Sept 22, 2016 through October 6 4:00 PM PST
Proposal Due Date	October 17, 2016 @ 4:00 PM PST. (Ad1)
Evaluation of Proposals	October 14 to October 21, 2016
Evaluation Panel Meeting	October 20, 2016
Presentations to the Panel (if required)	TBD
MOU Approval	Scheduled for the Board of Public Utilities (BPU) meeting of November 17, 2016
Design Workshop	Design workshop shall be scheduled approximately 4 weeks after MOU approval.
Updated Price Proposal	January XX, 2020
Updated MOU Execution	January XX, 2020
Design Workshop	February 2020

Final Price Proposal Negotiation	June 2020
Submission of Best and Final Offer	Final offer shall be negotiated approximately 4 weeks before the installation project goes to Bid. Estimated November 2020

ARTICLE 3 - EXAMINATION OF PROCUREMENT DOCUMENTS

- 3.01 It is the responsibility of each Supplier, before submitting a Proposal, to:
- A. Thoroughly examine the Procurement Documents.
 - B. Consider federal, state, local laws and regulations and contract and insurance requirements that may affect cost, progress, performance, or furnishing of the System and associated Work.
 - C. Notify Purchasing Agent of all conflicts, errors, discrepancies, or questions discovered by Supplier in the Procurement Documents by email before the close of the question and answer period.
- 3.02 Supplier's representation: The submission of a Proposal will constitute an incontrovertible representation by the Supplier that Supplier has complied with every requirement concerning examination of the Procurement Documents and the site, that without exception the Proposal is premised upon performing and furnishing the System and Work required by the Procurement Documents, and that the Procurement Documents are sufficient in scope and detail to indicate and convey understanding of all terms and conditions for performance.

ARTICLE 4 - INTERPRETATIONS AND ADDENDA

- 4.01 CITY reserves the right to revise or amend the specifications or any other part of the RFP up to the time set for opening. Such revisions and amendments, if any, shall be announced by addendum to this solicitation via Planet Bids. **Any addenda must be signed by the prospective Supplier and included in the proposal response.** If revisions and amendments require material changes to the RFP, the date set for opening of proposals may be postponed by such number of days as in the opinion of the CITY shall enable Suppliers to adequately revise Proposals. In any case, the Proposal opening shall be at least five working days after the last addendum; and the addendum shall include an announcement of the new date, if applicable, for the opening of Proposals.
- 4.02 All questions about the meaning or intent of the Procurement Documents, exceptions, offers and counter offers will be extended through the CITY's primary point of contact (Purchasing Agent) whose name appears on page 1 of this document. Questions must be submitted to Purchasing Agent via email in writing before the close of the questions and answer period identified within this solicitation. Interpretations or clarifications considered necessary by CITY in response to such questions will be issued by Addenda via Planet Bids. All other questions not subject to addenda will be posted as a Word document, are for informational purposes only, and do not change the content of this RFP.

- A. Questions received after 4PM PST on October 6, 2016 will not be answered.

ARTICLE 5 - PROPOSAL SECURITY – (REDACTED)

ARTICLE 6 - PROPOSAL FORM

- 6.01 The intent of the RFP is to encourage responses that clearly communicate the Supplier's understanding of the CITY's requirements and its approach to successfully provide the System and Work associated on time and within budget. The CITY reserves the right to retain the Supplier's services for possible future opportunities identified by the CITY forthcoming upon satisfactory completion of the identified projects within this RFP.
- 6.02 One original copy of Section 00410 - Proposal Forms must be submitted with the Proposal.
- 6.03 Section 00410 - Proposal Form must be completed and signed in ink and dated by an authorized officer of the Supplier, as specified. The names of all persons signing shall be legibly printed below their signatures. A Proposal by a person who affixes to his signature the word "president," "secretary," "agent," or other designation without disclosing his principal may be held to be the Proposal of the individual signing. When requested by CITY, evidence of the authority of the person signing shall be furnished.
- 6.04 The Proposal shall contain a copy of all signed Addenda. Acknowledgment of receipt of all Addenda, the numbers and dates of which shall be filled in on Document 00410 - Proposal Form.
- 6.05 No alterations in Proposals, or in the printed forms, by erasures, interpolations, or otherwise will be acceptable unless each such alteration is signed or initialed by the Supplier; if initialed, CITY may require the Supplier to identify any alteration so initialed.

ARTICLE 7 - SUBMISSION OF PROPOSAL

- 7.01 Supplier shall follow Proposal requirements as stated in Section 00300 and shall assume full responsibility for timely delivery at the location designated for receipt of Proposals. Proposals received after the time and date for receipt of Proposals will be rejected by Purchasing Agent and returned unopened.
- 7.02 Oral, telephone, facsimile, or telegraph Proposals are invalid and will not receive consideration.
- 7.03 No Supplier may submit more than 1(one) Proposal. Multiple Proposals under different names will not be accepted from one firm or association.

- 7.04 The Supplier is directed to collect and submit any information it deems to be proprietary or confidential in nature in a separate marked and sealed package. If there is no confidential information, then the Supplier should include a statement to that effect. Subject package shall be submitted in accordance with the terms and conditions governing the submittal of Supplier's Proposal to this RFP. Blanket-type identification by designating whole pages or sections as containing proprietary information, trade secrets or confidential commercial and financial information shall not ensure confidentiality. The specific proprietary information, trade secrets or confidential commercial and financial information must be clearly identified as such.

ARTICLE 8 - MODIFICATION AND WITHDRAWAL OF PROPOSALS

- 8.01 Proposals may be modified or withdrawn by an appropriate document duly executed (in the manner that a Proposal must be executed) and delivered to the place where Proposals are to be submitted at any time prior to the opening of Proposals.
- 8.02 If prior to the date fixed for submission of Proposals, a Supplier submitting a Proposal knows of or should have known of an error in the solicitation document but fails to notify the CITY of the error, the Supplier shall bid at its own risk, and if the Supplier is awarded the contract, it shall not be entitled to additional compensation or time by reason of the error or its later correction.
- 8.03 If, within 24 hours after Proposals are opened, any Supplier files a duly signed, written notice with CITY and promptly thereafter demonstrates to the reasonable satisfaction of CITY that there was a material and substantial mistake in the preparation of its Proposal, that Supplier may withdraw its Proposal and the Proposal security will be returned. Thereafter, that Supplier will be disqualified from further bidding on the Work to be provided under the Contract Documents.
- 8.04 After the proposals are opened, proposals may not be withdrawn for ninety (90) calendar days. Prior to the date/time set for the proposal opening, however, proposals may be modified or withdrawn by the bidder's authorized representative in person, or by written telegraphic notice. If proposals are modified or withdrawn in person, the authorized representative shall make his identity known and shall sign a receipt for the proposal. Written notices shall be received in the office of the Purchasing Agent.

ARTICLE 9 - EVALUATION OF PROPOSALS AND NEGOTIATIONS

- 9.01 METHOD OF SELECTION:
- A. An evaluation panel will review all qualified Supplier Proposals submitted and select the top Proposal. Additional questions may be asked of Suppliers. Suppliers will be notified of any additional required information after the written Proposals have been evaluated. The recommended award and MOU will be submitted to the CITY's Board of Public Utilities for approval. Overall responsiveness to the RFP is an important factor in the evaluation process. The selection will be made by a committee determined by the CITY. Once the selection has been made, such selection is final.
- B. CITY's treatment facility flow requirements are provided in Technical Specifications, Section 11289, Part 1.05. The facility uses multiple process units to treat wastewater flows. The CITY expects to procure quality UV equipment via the Contractor and

Supplier that will serve the intended process function over the life of the equipment without undue preventive or corrective maintenance. The CITY requires the use of equipment that has been successfully used at other similar wastewater treatment plants. To be selected, a Supplier must demonstrate through its Proposal that:

1. The Supplier and its parent firm is an established, financially stable, ongoing business.
 2. The equipment model proposed by the Supplier complies with the attached Technical Specifications. Each technical feature required by the Technical Specification must be provided. Minor exceptions may be waived at the discretion of the CITY, at the time of the review of the proposal.
 3. The exceptions taken by the Supplier do not affect the quality, performance, durability, or longevity of the equipment.
 4. System proposed has a verifiable track record of both performance and service at facilities similar to the LTP, and be of similar size and used in a similar application to that required at the LTP. Verification will be provided through scored independent reference checks performed by Purchasing Agent.
 5. The System proposed requires an acceptable level of preventive maintenance.
 6. The Supplier must have an active service organization currently available in the vicinity of the CITY, readily accessible to the CITY, and the Supplier must have an active parts-stocking warehouse and service facility where all parts of any supplied equipment can be obtained and/or repaired in the United States or Canada, readily accessible to the CITY.
- C. Additional information, test data, or clarification of information presented by the Supplier in the Proposal or obtained from references may be requested as part of the evaluation process. Written responses by the Supplier will be considered part of its Proposal if received within the requested time period.
- D. This RFP does not commit the CITY to enter into a contract, nor does it obligate the CITY to pay for any costs incurred in preparation and submission of proposals or in anticipation of a contract. The CITY reserves the right to:
- Make the selection based on its sole discretion.
 - Reject any and all proposals.
 - Issue subsequent Requests for Proposals.
 - Postpone opening proposals for its own convenience.
 - Remedy errors in the RFP process.
 - Approve or disapprove the use of particular subcontractors.
 - Negotiate with any, all or none of the Suppliers.
 - Accept other than the lowest offer.
 - Waive informalities and irregularities in the Proposals.
 - Enter into an agreement/MOU with another Supplier in the event the originally selected Supplier defaults or fails to execute an agreement with the CITY.
 - Negotiate the Best and Final Offer with Supplier.

An agreement shall not be valid or binding on the CITY unless and until it is approved by the CITY's Board of Public Utilities and executed by authorized representatives of the CITY and Supplier.

- E. The Supplier will be evaluated based on a decision matrix with the following evaluation criteria, in order of importance:
 - 1. Life cycle cost including initial construction.
 - 2. Service support, service location, and parts availability.
 - 3. Access and maintenance ease.
 - 4. Overall responsiveness to RFP.
 - 5. Status of DDW approval.
 - 6. Reference checks.
 - 7. Operational ease.
 - 8. Equipment features.
 - 9. Equipment Cost.
 - 10. Equipment footprint.

ARTICLE 10 - REJECTION OF PROPOSALS

- 10.01 CITY reserves the right to reject any or all Proposals, including without limitation the rights to reject any or all nonconforming, nonresponsive, or conditional Proposals, and to reject the Proposal of any Supplier if CITY believes that it would not be in the best interest of CITY to make an award to that Supplier. CITY also reserves the right to waive formalities.
- 10.02 CITY may reject any or all Proposals and may or may not waive an immaterial deviation or defect therein. The CITY's waiver of an immaterial deviation or defect shall in no way modify the solicitation document or excuse a Supplier from full compliance with solicitation document specifications. The CITY reserves the right to accept or reject any or all of the items in the Proposal, to award the contract in whole or in part and/or negotiate any or all items with individual Suppliers if it is deemed in the CITY's best interest. Moreover, the CITY reserves the right to make no selection if Proposals are deemed to be outside the fiscal constraint or against the best interest of the CITY.
- 10.03 CITY may conduct such investigations as CITY deems necessary to assist in the evaluation of any Proposal and to establish the responsibility, qualifications, and financial ability of Suppliers, proposed subcontractors, and other persons and organizations to perform and furnish the Goods and Services in accordance with the Procurement Documents to CITY's satisfaction within the prescribed time.
- 10.04 If only one proposal is received in response to the RFP, a detailed cost proposal may be requested of the single Supplier. A cost/price analysis and evaluation and/or audit may be performed of the cost proposal in order to determine if the price is fair and reasonable.

ARTICLE 11 - COMPETENCY OF FIRMS

11.01 No Proposal will be accepted from a firm who is not licensed in accordance with the law, who does not hold a license qualifying him to perform work under this contract, to whom a proposal form has not been provided and who has not successfully performed on projects of similar character and scope. The Supplier may be required, before the award of any contract, to show, to the complete satisfaction of the CITY, that it has the necessary facilities, ability, experience, and financial resources to provide the services specified herein in a satisfactory manner. Generally, Supplier history and references are required at a minimum. The CITY may make reasonable investigations deemed necessary and proper to determine the ability of a Supplier to perform the work, and the Supplier shall furnish the CITY all information requested for this purpose.

ARTICLE 12 - SALES AND USE TAXES

12.01 Provisions for sales and use taxes are set forth in the Proposal Form. Firms must be registered to do business in the State of California and have a current CITY of Santa Rosa Business Tax certification on file before a contract will be awarded.

ARTICLE 13 - LAWS AND REGULATIONS (REDACTED)

END OF DOCUMENT

SECTION 00300

REQUEST FOR PROPOSAL REQUIREMENTS

PART 1 - GENERAL

1.01 GENERAL INFORMATION

Supplier shall submit the following information (A through H) for the RFP to be qualified as responsive:

One original, signed in ink proposal that must include an original completed in ink and signed Document 00410 Proposal Form. Six (6) hard copies and one electronic copy on CD or USB drive of the Proposal information shall be submitted in a separate envelope from the original proposal.

- A. Proposals MUST be submitted at the time and place indicated in the solicitation and on Planet Bids, or at the modified time and place indicated by Addenda. Proposals shall be enclosed in an opaque, sealed envelope or box addressed to:

BRANDALYN TRAMEL, PURCHASING AGENT

CITY OF SANTA ROSA PURCHASING OFFICE

635 FIRST ST., 2ND FLOOR

SANTA ROSA, CA 95404

RFP 16-71 Ultraviolet (UV) Light Disinfection Equipment System Proposal

Proposals shall be marked with the name and address of the Supplier and contain all required documents. If the Proposal is sent through the mail or other delivery system, the sealed envelope shall be enclosed in a separate envelope, with the notation "PROPOSAL ENCLOSED" on the face of it.

Suppliers shall not contact any other CITY staff members or Consultant. All questions directed to Brandalyn Tramel, Purchasing Agent as outlined in Document 00200.

- B. Complete responses to Sections Section 00300, Parts 1.02 through 1.06 below, including Tables 00300-1 and 00300-2.
- C. Complete Attachment A, Attachment B and Attachment C to this Section 00300.
- D. Section 00410 - Proposal Form, one original copy must be completed in ink with the Proposal.
- E. Proprietary Information: The Supplier is directed to collect and submit any information it deems to be proprietary or confidential in nature in a separate marked and sealed package. If there is no confidential information, then the Supplier should

include a statement to that effect. Subject package shall be submitted in accordance with the terms and conditions governing the submittal of Supplier's Proposal to this RFP. Blanket-type identification by designating whole pages or sections as containing proprietary information, trade secrets or confidential commercial and financial information shall not ensure confidentiality. The specific proprietary information, trade secrets or confidential commercial and financial information must be clearly identified as such.

- F. City of Santa Rosa MOU: Supplier will be required to execute a City of Santa Rosa MOU substantially similar to the sample provided in Section 00525 MOU. Proposals should include a statement indicating Supplier's willingness and ability to execute this document "as is", or so indicate changes as part of the Proposal and reasons therefor.
- G. City of Santa Rosa Professional Services Agreement: Supplier will be required to execute a City of Santa Rosa Professional Services Agreement (PSA) for design assistance services in substantially the same form provided in Section 05500. Proposals should include a statement indicating Supplier's willingness and ability to execute this document "as is", including the provision of insurance requirements (Attachment One), or so indicate changes as part of the Proposal and reasons therefor.
- H. Conflicts of Interest: Suppliers submitting a Proposal in response to this RFP must disclose any actual, apparent, direct or indirect, or potential conflicts of interest that must exist with respect to the firm, management, or employees of the firm or other persons relative to the System and Work to be provided under the MOU to be awarded pursuant to this RFP. If the Supplier has no conflicts of interests, a statement to that effect shall be included in their Proposal.
- I. Certification and Signature:
 - 1. Certification of the accuracy of the information provided in the RFP shall be provided by completing the form in (Document 00300 Attachment B).
 - 2. All names must be typed or printed on the line with the signature.
 - 3. The address and telephone number of the entities representative for communications regarding the RFP must be submitted.

1.02 UV DISINFECTION SYSTEM DESIGN AND PERFORMANCE

Only that information which is essential to an understanding and evaluation of the proposal should be submitted. Items not related to the RFP and proposal, e.g., generalized brochures, marketing material, etc., will not be considered in the evaluation.

Supplier shall provide the design and performance criteria for the UV disinfection system, including the following information, in the order shown with dividers to clearly separate the information:

- A. Project Understanding. Include a section that demonstrates an overall understanding of the California Code of Regulations Title 22 treatment requirements, and proposed configuration to meet the requirements of the Technical Specifications.

- B. Process Description. Provide a brief description of the process being proposed for the System including all ancillary items. The description should include the proposed UV disinfection technology, advantages, energy use, and UV lamp cleaning and maintenance requirements. The process described above must also be used as the basis of design for the Proposal.
- C. Process Flow Diagram (PFD). A PFD of the System schematic shall be provided to show, as a minimum, the following:
1. All major flow streams.
 2. All major components.
 3. Additional information necessary to completely illustrate the process.
 4. Indicate the equipment that will be provided as part of the proposal and the equipment considered by the Supplier to be supplied by others.
- D. A detailed list: of all equipment, valves, instrumentation devices, and appurtenances being provided by the Supplier, as well as all such items necessary for the installation, calibration, and operation of the system. Include manufacturers and general specifications. The list shall include quantity and designation of all System components. All items shall be numbered and coordinated with the PFD of the System schematic.
- E. A detailed layout drawing of the System. The drawing shall show equipment dimensions, clearances between units, clean-in-place system components, rinse water and neutralization system, air supply system (if required), electrical control panels and motor control centers, pneumatic or hydraulic systems, and all other ancillary equipment for a complete operating the System. The layout drawing shall show the UV modules and banks required for a complete disinfection System. This drawing shall be to a minimum of 1/4" = 1'-0" scale, and should be based on the plans and sections included in this RFP. An elevation or section drawing of the System shall also be provided. The elevation drawing shall specify required clearance height and equipment dimensions, and shall also be to a minimum scale of 1/4" = 1'-0".
- F. Preliminary Process and Instrumentation Diagrams (P&IDs). This RFP includes preliminary P&IDs. The Proposal shall include updated P&IDs which clearly show the locations and types of control valves and instruments, and indicate how the UV disinfection processes are to be monitored and controlled. A written description of the instrumentation and control scheme shall also be included in the Proposal. The P&IDs shall clearly indicate equipment that is part of the Bid and equipment considered by Supplier to be supplied by others.
- G. Catalog data and dimensional plan and section drawings that depict the UV disinfection system components proposed.
- H. Information on the design features and options for instrumentation and controls for the proposed UV disinfection system in accordance with the Technical Specifications.
- I. Materials of construction and optional materials of construction for all major components and wear surfaces for the proposed UV disinfection system in accordance with the Technical Specifications.

- J. Any information that indicates the track record of the proposed UV disinfection system for ease of operation, ease of maintenance, safety, housekeeping and leakage, equipment ventilation and any other factors that the Supplier would like to be considered.
- K. A description of the operational steps necessary to isolate and remove a channel or bank from service; to identify, isolate, and remove a defective lamp or modules. The description shall clearly identify the means to provide access to the channel and equipment removal for channel cleaning.
- L. A description of the System turndown capabilities (variable power output), and a discussion of the impact of power turndown on lamp performance relative to disinfection capabilities.

1.03 EQUIPMENT WARRANTIES, SERVICE, SUPPORT AND MAINTENANCE CAPABILITIES

The Supplier shall provide the following information related to equipment warranties, service, support, and maintenance capabilities:

- A. General System Warranty. The Supplier shall provide details and conditions of the Supplier's proposed system warranty. The minimum warranty requirements are specified in Section 11289, Low-Pressure High-Output Ultraviolet Disinfection Systems.
- B. UV Lamp Warranty. The Supplier shall provide details and conditions of the warranty proposed for the UV lamps, and the performance of the UV lamps. The minimum warranty requirements are specified in Section 11289, Low-Pressure High-Output Ultraviolet Disinfection Systems.
- C. UV Ballast Warranty. The Supplier shall provide details and conditions of the warranty proposed for the UV ballasts, and the performance of the UV ballasts. The minimum warranty requirements are specified in Section 11289, Low-Pressure High-Output Ultraviolet Disinfection Systems.
- D. UV Sleeve Warranty. The Supplier shall provide details and conditions of the warranty proposed for the UV sleeves. The minimum warranty requirements are specified in Section 11289, Low-Pressure High-Output Ultraviolet Disinfection Systems.
- E. UV Sensor Extended Warranty. The Supplier shall provide details and conditions of the warranty proposed for the UV wipers, and the performance of the UV wipers. The minimum warranty requirements are specified in Section 11289, Low-Pressure High-Output Ultraviolet Disinfection Systems.
- F. Equipment Service. The Supplier shall describe procedures for obtaining service of the UV disinfection equipment system during and after the warranty period including lead-time for delivery.
- G. Maintenance Schedule. Provide a maintenance schedule for significant routine maintenance of the UV disinfection system equipment. List all maintenance procedures that cannot be performed while the system is in operation.

- H. UV Lamp Installation. Suppliers shall allow for in their design and include provisions for installing and replacing UV lamps and other components of their UV system. This shall include allowing sufficient space in and around the UV channel, banks and other items that can be expected to need maintenance or replacement. In addition, if special equipment is needed to remove, replace, and/or maintain the UV lamps, ballasts or any other piece of the UV disinfection system equipment, the need for, description of, and cost for such special equipment shall be included in the Bid. Such information shall also be provided for any equipment within the Equipment List that requires routine maintenance and/or periodic removal and that has a gross weight, including the weight of any water contained therein that is equal to or exceeds 50 pounds.
- I. UV Lamp/Ballast/Sleeve/Wiper Failure. Each Supplier shall address how a failure of the major UV system components listed above is discovered and located and how such a failure can be repaired or element replaced. Any special tools or procedures needed to accomplish this task as well as the labor hours required and an indication of the skill level or training needed shall also be described.
- J. Spare Parts and Maintenance Locations. The Supplier shall list the addresses for all spare parts warehouses and maintenance facilities located in the United States. State the dollar amount of the spare parts inventory maintained at each warehouse. List all spare parts not available in the United States for the proposed UV disinfection system. Identify the approximate costs and delivery times of all major spare parts for the UV disinfection system proposed. The Supplier shall provide a detailed list of the spare parts with associated itemized price. Spare pricing shall not increase annually at a rate greater than the price adjustment stated on the Bid Form.

1.04 EXPERIENCE, QUALIFICATIONS, AND MANUFACTURING CAPABILITIES

The Supplier shall demonstrate their ability to undertake the Project by providing evidence of their experience, qualifications and manufacturing capabilities related to the design and construction of projects comparable to the Project. References listed within the statement of qualifications WILL be contacted and scored. No more than three attempts will be made to contact each reference. If an invalid phone number is provided for a reference, the CITY will contact the Supplier via email one time to provide an opportunity to provide a valid phone number.

As a minimum, the Supplier shall provide the following information to demonstrate their ability:

- A. Worldwide, including North American Installations. Furnish a worldwide user list for the proposed UV disinfection system technology in municipal wastewater treatment applications. Do not include system experience for closed vessels, or potable water treatment systems.
- B. Three Largest Installations. Provide information in Table 00300-1 (at the end of this section) for the three largest, worldwide open-channel UV disinfection systems designed for municipal wastewater applications (functional and operational for a minimum of one year).

- C. Future Installations. Provide a list of open-channel installations using the proposed UV disinfection system that are either in design and/or will start up over the next two years in North America.
- D. State of California Installations:
1. List UV disinfection installations for the proposed UV disinfection system manufactured by the UV equipment system Supplier in California in the last five years. For each installation include the location, operation start date, average daily flow, maximum month and/or peak hour flow, design dose, number of banks and lamps, and the number of channels. If none with the proposed offering, list the three most recent California Code of Regulations Title 22 installations.
 2. Furnish operating data for UV disinfection installations for municipal wastewater applications in North America (operating for a minimum of one year) equal to or greater than a capacity 15 mgd, average daily flow. Provide the information in Table 00300-2 (at the end of this section) for each installation.
- E. Performance Record. Supplier shall provide information listed in Table 00300-2 (at the end of this section) for its five largest open-channel UV disinfection installations that have been in service for at least 1 year in the State of California, and that are approved for use for Title 22, Unrestricted Reuse project. If none with the proposed offering, list the most recent California Title 22 installations.
- F. System Reliability. Provide a one-page summary documenting the reliability of the UV disinfection system. Specifically address information that documents the lamp aging and the ability cleaning system to prevent lamp fouling, including the quartz sleeve cleaning system mechanism reliability. Reports that document UV lamp aging or the reliability of the cleaning systems shall be included as an attachment to the Proposal.
- G. Quality control and quality assurance (QA/QC). Provide a discussion regarding QA/QC procedures; discuss which components of the UV disinfection systems are fabricated in-house, which components are out-sourced. When components are out-sourced, discuss where they are out-sourced, and how the QA/QC is conducted with out-sourced Suppliers. Include a discussion relating to where the control panels are designed, assembled, and tested. As an alternative, provide verification and proof that Supplier performs yearly ISO 9001 audits.

1.05 ENGINEERING SUPPORT, TEAM EXPERIENCE AND CAPABILITIES

Proposals must contain a statement as to qualifications of the proposing firm, and identify the project manager, staff, and subcontractors that would have assignments under the MOU, and provide resumes that fully describe team qualifications, experiences, and projects for which they had "hands on" responsibility. Also include length of time with the firm. The project manager will be expected to be fully involved and conversant in the details of the project on a day-to-day basis. Describe the organization structure of staff members and sub-consultants (if any).

Firms must be registered to do business in the State of California before a contract will be awarded.

The Supplier shall provide the following information related to engineering support, and team experience and capabilities:

- A. Organizational Chart. The Supplier shall provide an organizational chart that lists the staff in North America for management, sales, process design, engineering design, field startup, and field service. Indicate number of staff in each category, location, and years of experience for each individual.
- B. Assigned Project Manager. The Supplier shall assign a dedicated project manager that will be the point of contact for the entire duration of the Project (from design through start-up). The Supplier will provide a resume for the project manager and a list of at least three references for recently completed projects. Any changes of the project manager will have to be approved by the CITY. Provide the level of availability the proposed project manager will be assigned to work on this Project.
- C. Key Project Staff. The Supplier shall provide resumes and qualifications of proposed key staff, including but not limited to, the project engineer, and discipline lead engineers, start-up, and training staff that will be assigned to this project.

1.06 CORPORATE STABILITY AND FINANCIAL CAPABILITIES

The Supplier shall provide full disclosure of its financial position, and if applicable, the financial position of the corporation guaranteeing the Supplier's obligations under a contract eventually executed. Financial information submitted as part of this RFP shall include the following:

- A. Ownership Structure. Describe in detail, the ownership structure of the Supplier including the parent company, intermediate owners and the UV disinfection manufacturing entity. State the length of ownership for the parent company and the years of experience of the manufacturing entity in manufacturing UV disinfection systems.
- B. Financial Statements. Furnish audited or reviewed financial statements for the Supplier for the last three years that detail sales, earnings, balance sheets and income statements, and statements of changes in financial position.
- C. Corporate Stability. Identify any bankruptcies, and mergers or acquisitions experienced by the Supplier and its affiliates during the past five years, as well as disclosure of any potential mergers or acquisitions.
- D. Litigation. The Supplier shall disclose any outstanding litigation that could potentially impact its financial condition if judgment is brought against the Supplier. This section shall include a listing of any claim, lawsuit or litigation and the result of that action resulting from (a) any public project undertaken by the Supplier either as a contractor or subcontractor or by its subcontractors where litigation is still pending or has occurred within the last five years, or (b) any type of project where claims or settlements were paid by the Supplier or its insurers within the last five (5) years. If none of the above legal action or issues apply, supply a statement to that affect. Firms must be registered to do business in the state of California before MOU will be awarded.

- E. Supplier shall provide a list of all wastewater and water reuse UV Disinfection system sales in North America, including both contracted projects, and projects where the supplier has been selected, since January 1st, 2015. List of system sales shall include plant name, location, peak flow rate, design UV transmittance, equipment model, and number of lamps supplied or proposed."

Table 00300-1 Reference Installation Information				
		Installation No. 1	Installation No. 2	Installation No. 3
a.	Facility Name			
b.	Facility Location			
c.	Owner/ Contact Person with Detailed Knowledge of UV system Operation (provide name, telephone and e-mail)			
d.	Design Engineer Contact Information (provide name, telephone and e-mail)			
e.	General Contractor Contact Information (provide name, telephone, e-mail)			
f.	Design Capacity (average daily flow and peak hourly flow), mgd			
g.	Facility Description (number of installed channels, banks and modules/bank)			
h.	Total number of lamps installed			
i.	Design UV transmittance (%)			
j.	Design UV dose (mJ/cm ²)			
k.	Operation Start Date, month-year			
l.	Maintenance Cleaning Regimen, Chemical Type and Frequency			
m.	Operation Start Date, month-year			
n.	Additional Comments			

Table 00300-2 Performance Record for Five Largest UV Disinfection System for Municipal Installations in the State of California for Production of Title 22 Tertiary Water					
Item	Location 1	Location 2	Location 3	Location 4	Location 5
Facility: Name, location, capacity and design criteria of UV Disinfection System					
Owner Contact (provide name, telephone and e-mail)					
Engineer Contact (provide name, telephone and e-mail)					
Contractor Contact (provide name, telephone and e-mail)					
Submittal Date and Accepted Submittal Date					
Scheduled Equipment Delivery Date					
Actual Equipment Delivery Date					
Startup Date					
Approval Date by DDW (formerly CDPH) for Title 22					
Listing of all spare parts shipped by Supplier after Startup Date for warranty repairs					

DOCUMENT 00300 - ATTACHMENT A - PASS/FAIL REQUIREMENTS
An answer of “no” to any of the following questions will disqualify the Supplier

1. Has the Supplier been manufacturing UV disinfection equipment systems specifically designed for municipal wastewater, continuously for the last ten years or longer?
 Yes No

2. Are the UV lamps of the proposed UV Disinfection System, Amalgam Low-Pressure, High-Output lamps designed for open-channel UV Disinfection Systems?
 Yes No

3. Has the Supplier attached the latest copy of an audited or reviewed financial statement with accompanying notes and supplemental information? **NOTE: A financial statement that is not audited or reviewed is not acceptable.**
 Yes No

4. Has the **dose equation** from the 2012 NWRI Ultraviolet Guidelines validation, which is used for sizing and operating the proposed UV disinfection system been documented in an engineering report that has been stamped by an independent, third party, engineer licensed in the United States; and, has the report been approved by the California Department of Drinking Water (DDW) or submitted to the DDW for approval before the Proposals are due, in order to gain Conditional Acceptance of the proposed UV Disinfection system, and approved by the DDW prior to bidding the installation? Note the CITY reserves the right to reject Suppliers that are not approved prior to the installation bid date (estimated January 2018).
 Yes No

5. Has the Supplier included the required owner and contractor references?
 Yes No

6. Has the Supplier designed, manufactured, and supplied an open-channel, municipal wastewater, UV disinfection system that utilizes variable ballasts, for an installation in California used to produce tertiary recycled water in accordance with Title 22 Code requirements, that has been in operation for at least one year?
 Yes No

7. Has the Supplier designed, manufactured, and supplied an open-channel, municipal wastewater, UV disinfection system that has an average daily flow capacity greater than or equal to 9.5 mgd, is installed in the United States, and in operation for at least six months?
 Yes No

8. Is the Ultraviolet disinfection equipment, modules and support frames, fully removable from the plan view footprint of the channel without disassembly? Leaving components of the modules in or above the channel is not acceptable, and the entire channel must be clear of UV equipment for cleaning, with modules removed to the side of the channels?
 Yes No

DOCUMENT 00300 - ATTACHMENT B - AFFIDAVIT

We, the undersigned, _____ (name) as the authorized representatives for _____ (company) an interested UV disinfection manufacturer for the City of Santa Rosa UV Disinfection Improvements Project, do hereby attest that all statements and representations made herein are true and correct to the best of our knowledge. These statements are made openly and freely without intent to influence or embellish actual conditions or circumstances that occurred. I/We declare under penalty of perjury under the laws of the State of California that the foregoing is correct.

We acknowledge that we have received Addenda _____ through _____.

We understand that the CITY will investigate any and all statements and representations made by us and our firm in this Statement of Qualifications Package and we freely give our permission for them to do so. Should releases be required by any of our professional, financial, or bonding institutions to release verification of the enclosed data, we have provided them. We agree to waive any claims against the CITY, ENGINEER and/or any third party designated by the CITY for the release of the information necessary to evaluate this Statement of Qualification and Proposal Package.

We further understand that any false statement or representations made in this application will result in disqualification of our firm as a Supplier for the Project. If it is determined that these false statements or representations were purposefully made to change, hide, or obscure negative information from the CITY in an attempt to qualify under these false pretenses, the action will result in loss of eligibility for our firm to qualify for any City of Santa Rosa contracts for a minimum period of one (1) year and a maximum period of five (5) years from the date of discovery. If the discovery of false representation occurs after the contract is awarded to our firm, we understand and agree that the CITY reserves the right to terminate the contract for cause and to seek legal remedy under the prevailing statutes.

(Name)

(Signature)

(Title)

Attested: _____ Corporate Seal

(Name)

(Signature)

(Title) DATE _____, 2016

**DOCUMENT 00300 - ATTACHMENT C –
NON-COLLUSION AFFIDAVIT AND WILLINGNESS TO SIGN
RFP 16-71**

STATE OF CALIFORNIA
CITY OF SANTA ROSA

_____ declares and says:

1. That he/she is the (owner, partner, representative, or agent)

of _____, hereinafter referred to as
(SUPPLIER).

2. That he/she is fully informed regarding the preparation and contents of this proposal for certain work in the City of Santa Rosa, State of California.

3. Recognizes that this acknowledgement is a statement indicating the firm's willingness and ability to sign the standard contract form (MOU Sample) "as is", including proposed insurance requirements (Attachment One), or detailing the reasons why SUPPLIER is not willing or able to do so by providing a redlined copy of the MOU Sample in tracked changes as part of a completed submittal.

4. The SUPPLIER declares, by signing this document and submitting a submittal, that the submittal is not made in the interest of, or on behalf of, any undisclosed person, partnership, company, association, organization, or corporation; that the submittal is genuine and not collusive or sham; that the SUPPLIER has not directly or indirectly induced or solicited any other SUPPLIER to put in a false or sham submittal, and has not directly or indirectly colluded, conspired, connived, or agreed with any revenue audit SUPPLIER or anyone else to put in a sham submittal, or that anyone shall refrain from bidding; that the auditor has not in any manner, directly or indirectly, sought by agreement, communication, or conference with anyone to fix the submittal price of the financial advisor or any other bidder, or to fix any overhead, profit, or cost element of the submittal price, or of that of any other revenue audit SUPPLIER, or to secure any advantage against the public body awarding the contract of anyone interested in the proposed contract; that all statements contained in the submittal are true; and, further, that the SUPPLIER has not, directly or indirectly, submitted his or her submittal price or any breakdown thereof, or the contents thereof, or divulged information or data relative thereto, or paid, and will not pay, any fee to any corporation, partnership, company association, organization, submittal depository, or to any member or agent thereof to effectuate a collusive or sham submittal; and,

5. That the price or prices quoted in the submittal are fair and proper, and are not tainted by any collusion, conspiracy, connivance, or unlawful agreement on the part of the SUPPLIER, or any of its agents, owners, representatives, employees, or parties in interest, including this affiliate.

I certify (or declare) under penalty of perjury, that the foregoing is true and correct.

Dated this _____ day of _____, 2016, at _____, _____.
(City) (State)

Signed: _____

Printed Name: _____

Title: _____

END OF DOCUMENT

TECHNICAL SPECIFICATIONS

FOR

LAGUNA TREATMENT PLANT ULTRAVIOLET (UV) LIGHT DISINFECTION EQUIPMENT SYSTEM

REQUEST FOR PROPOSALS 16-71

September 2016

UPDATED PRICE REQUEST

DECEMBER 2019



Original
Signed
9/22/2016



In association with **Hazen**

SECTION 01110

SUMMARY OF WORK

PART 1 GENERAL

1.01 SUMMARY

- A. Section includes: Detailed description of the Work for the Supply of the UV Disinfection System.
- B. Related section:
 - 1. Section 11289 - Low-Pressure, High-Output UV Disinfection System.

1.02 THE WORK

- A. The Work consists of supply of the UV Disinfection Equipment System as described in Section 11289, including submittals, equipment, start-up, and commissioning services, spare parts, and coordination with the Contractor during installation. UV equipment will be installed in a new UV disinfection facility, the design will be based on the selected Supplier's equipment. Preliminary layouts, and electrical and control information is included in Appendix A of the Proposal documents.

1.03 LOCATION OF PROJECT

- A. The Work is located at City of Santa Rosa Laguna Treatment Plant (LTP):
 - 4300 Llano Road
 - Santa Rosa, CA 95407

1.04 ACTIVITIES BY OTHERS

- A. Activities by others that may affect performance of work include:
 - 1. None.

END OF SECTION

SECTION 01330

SUBMITTAL PROCEDURES

PART 1 GENERAL

1.01 SUMMARY

- A. Section includes: Requirements and procedures for submittals for UV equipment.
- B. Related section:
 - 1. Section 11289 - Low-Pressure, High-Output UV Disinfection System.

1.02 REFERENCES

- A. NSF International:
 - 1. NSF 61 - Drinking Water System Components – Health Effects.

1.03 DEFINITIONS

- A. Certificates: Describe certificates that document affirmations by the Supplier or other entity that the Work is in accordance with the Contract Documents.
- B. Extra stock materials: Describe extra stock materials to be provided for the City's use in facility operation and maintenance.
- C. Maintenance-material submittals: Use this article to categorize maintenance-material submittals requiring no Engineer action other than confirmation of receipt under an explanatory heading.
- D. Manufacturer's instructions: Instructions, stipulations, directions, and recommendations issued in printed form by the manufacturer of a product addressing handling, installation, erection, and application of the product; manufacturer's instructions are not prepared especially for the Work.
- E. Product data: Product data usually consists of manufacturers' printed data sheets or catalog pages illustrating the products to be incorporated into the project.
- F. Samples: Samples are full-size, actual products intended to illustrate the products to be incorporated into the project. Sample submittals are often necessary for such characteristics as colors, textures, and other appearance issues.
- G. Spare parts: Describe spare parts necessary for the City's use in facility operation and maintenance; identify the type and quantity here, but include the actual characteristics of the spare parts in the product as part of the specification of the product.
- H. Shop drawings: Shop drawings are prepared specifically for the project to illustrate details, dimensions, and other data necessary for satisfactory fabrication or construction that are not shown in the contract documents. Shop drawings could include graphic line-type drawings, single-line diagrams, or schedules and lists of products and their application.

- I. Submittals: Submittals are samples, product data, shop drawings, and others that demonstrate how Supplier intends to conform to the Contract Documents.
- J. Tools: Tools are generally defined as items such as special wrenches, gauges, circuit setters, and other similar devices required for the proper operation or maintenance of a system that would not normally be in the City's tool kit.

1.04 GENERAL INSTRUCTIONS

- A. Provide submittals that are specified or reasonably required for construction, operation, and maintenance of the Work.
- B. Provide submittal information from only 1 manufacturer for a specified product. Submittals with multiple manufacturers for 1 product will be rejected without review.
- C. Where multiple submittals are required, provide a separate submittal for each specification section:
 - 1. In order to expedite construction, the Supplier may make more than 1 submittal per specification section, but a single submittal may not cover more than 1 specification section.
 - 2. The only exception to this requirement is when 1 specification section covers the requirements for a component of equipment specified in another section.
- D. For example, circuit breakers are a component of switchgear. The switchgear submittal must also contain data for the associated circuit breakers, even though they are covered in a different specification section.
- E. Edit all submittals so that the submittal specifically applies to only the equipment furnished. Neatly cross out all extraneous text, options, models, etc., that do not apply to the equipment being furnished, so that the information remaining is only applicable to the equipment being furnished.
- F. Prepare submittals in the English language. Do not include information in other languages.
- G. Present measurements in customary, United States units (feet, inches, pounds, etc.).
- H. Show dimensions, construction details, wiring diagrams, controls, manufacturers, catalog numbers, and all other pertinent details.
- I. Indicate project-designated-equipment tag numbers from P&IDs for submittal of devices, equipment, and assemblies.
- J. Hardcopy submittals:
 - 1. Must be clear and legible, and of sufficient size for presentation of information:
 - a. Minimum page size will be 8 1/2 inches by 11 inches.
 - b. Maximum page size will be 11 inches by 17 inches.
- K. Submittals in electronic-media format:
 - 1. General: Provide all information in PC-compatible format using Windows operating system as utilized by the Engineer.

2. Text: Provide text documents and manufacturer's literature using current version of Adobe Acrobat (i.e., PDF extension), as utilized by the City and Engineer.
 3. Graphics: Provide all graphic submittals (drawings, diagrams) utilizing current version of Adobe Acrobat (i.e., PDF extension), as utilized by the Engineer and City.
- L. Approved Material List:
1. General: Provide the Approved Material List that documents all products that have been determined to be without exceptions through the submittal process. Maintain and update the list throughout the construction period. Provide City and Engineer with current copy of list weekly. Provide the list electronically in EXCEL file.
 2. Content: Provide Approved Material List in log form with columns titled, "Spec. Section", "Paragraph", "Submittal No.", "Approval Date", "Product Description", and "Manufacturer Name". Include only products submitted and found to be approved.

1.05 SUBMITTAL ORGANIZATION

- A. Fully indexed with a tabbed divider for every component.
- B. Sequentially number pages within the tabbed sections:
 1. Submittals that are not fully indexed and tabbed with sequentially numbered pages, or are otherwise unacceptable, will be returned without review.
- C. Organize submittals in the exact, same order that the items are referenced, listed, and/or organized in the specification section.
- D. For submittals that cover multiple devices used in different areas under the same specification section, the submittal for the individual devices must list the area where the device is used.
- E. Consolidate electronic-format submittals with multiples pages into a single file.

1.06 SUBMITTAL COVER SHEETS

- A. Submittal Transmittal Form is provided in Appendix A of this Section:
 1. Substitute forms require Engineer approval based on forms providing the same information, statements, and certifications.
 2. Submittal Number Field: Required submittal numbering format: Section number-sequential number-resubmittal number:
 - a. Example: 03200-002-1:
 - 1) "03200" indicates the affected specification is Section 03200.
 - 2) "002" indicates the second submittal under this Section.
 - 3) "1" indicates the first resubmittal of the Submittal.
 - b. Supplier may add a separate numbering scheme for Supplier's internal use. However, all correspondence with Engineer must include the required submittal numbering.
 3. "From" Field: Provide name and address of company responsible for preparation of submittal. This could be Supplier, subcontractor, vendor, manufacturer, etc.
 4. "Supplier" Field: Verify that the Supplier reviewed the submittal by signature.

- B. Supplier shall sign and date submittals to indicate review and approval:
1. Signature indicates Supplier certifies that they have satisfied submittal-review responsibilities and constitutes Supplier's written approval of submittal.
 2. Submittals without Supplier's signature will be returned to the Supplier not reviewed. Subsequent submittal of this information will be counted as the first resubmittal.
- C. Attachments:
1. Specification section: Include with each submittal a copy of the relevant specification section:
 - a. Indicate in the left margin, next to each pertinent paragraph, either compliance with a checkmark (✓) or a deviation with a consecutive number (1, 2, 3, etc.).
 - b. Provide a list of all numbered deviations with a clear explanation and reason for the deviation.
 2. Drawings: Include with each submittal a copy of the relevant Drawing, including relevant addendum updates:
 - a. Indicate either compliance with a checkmark (✓) or a deviation with a consecutive number (1, 2, 3, etc.).
 - b. Provide a list of all numbered deviations with a clear explanation and reason for the deviation.
 - c. Provide field dimensions and relationship to adjacent or critical features of the Work or materials.
- D. Supplier: Prepare submittal information in sufficient detail to show compliance with specified requirements:
1. Determine and verify quantities, field dimensions, product dimensions, specified design and performance criteria, materials, catalog numbers, and similar data.
 2. Coordinate submittal with other submittals and with the requirements of the Contract Documents.
 3. Check, verify, and revise submittals as necessary to bring them into conformance with Contract Documents and actual field conditions.

1.07 SUBMITTAL CONTENT

- A. For additional submittal content requirements see Specification Section 11289.
- B. Shop Drawings:
1. Details:
 - a. Fabrication drawings: drawn to scale and dimensioned.
 - b. Front, side, and rear elevations, and top and bottom views, showing all dimensions.
 - c. Locations of conduit entrances and access plates.
 - d. Component layout and identification.
 - e. Weight.
 - f. Finish.
 - g. Temperature limitations, as applicable.
 - h. Nameplate information.

- C. Product Information:
 - 1. Product Data:
 - a. Details:
 - 1) Vendor name and address.
 - 2) Subcontractor name and address.
 - b. Include:
 - 1) Catalog cuts.
 - 2) Bulletins.
 - 3) Brochures.
 - 4) Manufacturer's Certificate of Compliance: signed by product manufacturer along with supporting reference data, affidavits, and tests, as appropriate.
 - 5) Manufacturer's printed recommendations for installation of equipment.
 - 6) Quality photocopies of applicable pages from manufacturer's documents.
 - 2. Completely fill out a Motor Data Sheet, as specified in Section 16222, for every motor furnished:
 - a. Submit one copy of the Motor Data Sheet to the Engineer for review as part of the associated equipment submittal.
 - 3. Samples:
 - a. Details:
 - 1) Submit labeled samples.
 - 2) Samples will not be returned.
 - 3) Provide samples from manufacturer's standard colors, materials, products, or equipment lines:
 - a) Clearly label samples to indicate any that represent non-standard colors, materials, products, or equipment lines, and that if selected, will require an increase in Contract Time or Contract Price.
 - 4. Minor or incidental products and equipment schedules:
 - a. Details:
 - 1) Shop Drawings of minor or incidental fabricated products will not be required, unless requested.
 - 2) Submit tabulated lists of minor or incidental products showing the names of the manufacturers and catalog numbers, with Product Data and Samples as required to determine acceptability.
- D. Design calculations:
 - 1. Details:
 - a. Defined in technical sections.
 - b. Calculations must bear the original seal and signature of a Professional Engineer licensed in the State where the project is located and who provided responsible charge for the design.
- E. Qualifications Statements:
 - 1. Details:
 - a. Defined in technical sections.
 - b. Licensing documentation.
 - c. Certification documentation.
 - d. Education documentation.

- F. Quality assurance/control submittals:
1. Mill test reports:
 - a. Details:
 - 1) Submit certified copies of factory and mill test reports.
 - 2) Do not incorporate products in the Work that have not passed testing and inspection satisfactorily.
 - 3) Pay for mill and factory tests.
 2. Test reports:
 - a. Details:
 - 1) Include the following information:
 - a) A description of the test.
 - b) List of equipment used.
 - c) Name of the person conducting the test.
 - d) Date and time the test was conducted.
 - e) Ambient temperature and weather conditions.
 - f) All raw data collected.
 - g) Calculated results.
 - h) Clear statement if the test passed or failed the requirements stated in the Contract Documents.
 - i) Signature of the person responsible for the test.
 3. Factory Acceptance Test:
 - a. Details: Include complete test procedure and all forms to be used during test.
 4. Certificates:
 - a. Details: Defined in technical sections.
 - b. For products that will be in contact with potable water, submit evidence from a nationally recognized laboratory that the products comply with the requirements of the NSF 61 standard.
 5. Manufacturers' field reports:
 - a. Details: Manufacturer's Certificate of installation and functionality compliance.
 6. Field Samples:
 - a. Details: Defined in technical sections.
 7. Test Plans:
 - a. Details: Defined in technical sections.

1.08 SUBMITTAL PROCEDURE

1. Delivery: Deliver submittals to Engineer using web-based construction document management system.
 2. Timeliness: Schedule and make submissions in accordance with the requirements of the individual specification sections and in such a sequence as to cause no delay in the Work.
 3. Supplier assumes risk of expense and delays when proceeding with work related to required submittals without review and approval.
- B. Engineer: Review submittal and provide response:
1. Review description:
 - a. Engineer will be entitled to rely upon the accuracy or completeness of designs, calculations, or certifications made by licensed professionals accompanying a particular submittal, whether or not a stamp or seal is required by Contract Documents or Laws and Regulations.
 - b. Engineer's review of submittals shall not release Supplier from Supplier's responsibility for performance of requirements of Contract Documents.

- Neither shall Engineer's review release Supplier from fulfilling purpose of installation, nor from Supplier's liability to replace defective work.
- c. Engineer's review of shop drawings, samples, or test procedures will be only for conformance with design concepts and for compliance with information given in Contract Documents.
 - d. Engineer's review does not extend to:
 - 1) Accuracy of dimensions, quantities, or performance of equipment and systems designed by Supplier.
 - 2) Supplier's means, methods, techniques, sequences, or procedures, except when specified, indicated on the Drawings, or required by Contract Documents.
 - 3) Safety precautions or programs related to safety, which shall remain the sole responsibility of the Supplier.
 - e. Engineer can Approve or Not Approve any exception at their sole discretion.
2. Review timeframe:
- a. Except as may be provided in technical specifications, a submittal will be returned within 30 days.
 - b. When a submittal cannot be returned within the specified period, Engineer will, within a reasonable time after receipt of the submittal, give notice of the date by which that submittal will be returned.
 - c. Critical submittals:
 - 1) Supplier will notify Engineer in writing that timely review of a submittal is critical to the progress of the Work.
 - 2) Engineer will provide a decision upon request:
 - a) Written agreement by Engineer to reduce submittal review time will be made only for unusual situations.
 - b) Written rejection of request.
3. Schedule delays:
- a. No adjustment of Contract Times or Contract Price will be allowed due to Engineer's review of submittals, unless all of the following criteria are met:
 - 1) Engineer has failed to review and return first submission within the agreed-upon time frame.
 - 2) Supplier demonstrates that delay in progress of Work is directly attributable to Engineer's failure to return submittal within the time indicated and accepted by Engineer.
4. Review responses: 1 copy of submittal will be returned to Supplier with one of the following reviewer's response:
- a. Approved:
 - 1) No Exceptions:
 - a) There are no notations or comments on the submittal, and the Supplier may release the equipment for production.
 - 2) Make Corrections Noted - See Comments:
 - a) The Supplier may proceed with the Work, however, all notations and comments must be incorporated into the final product.
 - b) Resubmittal not required.
 - 3) Make Corrections Noted - Confirm:
 - a) The Supplier may proceed with the Work, however, all notations and comments must be incorporated into the final product.
 - b) Submit confirmation specifically addressing each notation or comment to the Engineer within 15 calendar days of the date of the Engineer's transmittal requiring the confirmation.

- b. Not approved:
 - 1) Correct and Resubmit:
 - a) Supplier may not proceed with the work described in the submittal.
 - b) Supplier assumes responsibility for proceeding without approval.
 - c) Resubmittal of complete submittal package is required within 30 calendar days of the date of the Engineer's submittal review response.
 - 2) Rejected - See Remarks:
 - a) Supplier may not proceed with the work described in the submittal.
 - b) The submittal does not meet the intent of the Contract Documents. Resubmittal of complete submittal package is required with materials, equipment, methods, etc., that meet the requirements of the Contract Documents.
 - c. Receipt Acknowledged: Filed for Record:
 - 1) This is used to acknowledge receipt of informational submittals that address means and methods of construction, such as schedules and work plans, conformance test reports, health and safety plans, etc.
- C. Supplier: Prepare resubmittal, if applicable:
- 1. Supplier to include design and controls workshop for submittal review in Walnut Creek, CA, Date to Be Determined. Workshop will facilitate the UV submittal review process.
 - 2. Clearly identify each correction or change made.
 - 3. Include a response in writing to each of the Engineer's comments or questions for submittal packages that are resubmitted in the order that the comments or questions were presented throughout the submittal:
 - a. Acceptable responses to Engineer's comments are listed below:
 - 1) "Incorporated" Engineer's comment or change is accepted and appropriate changes are made.
 - 2) "Response" Engineer's comment not incorporated. Explain why comment is not accepted or requested change is not made. Explain how requirement will be satisfied in lieu of comment or change requested by Engineer.
 - b. Reviews and resubmittals:
 - 1) Vendors shall provide resubmittals that include responses to all submittal-review comments separately and at a level of detail commensurate with each comment.
 - 2) Vendor responses shall indicate how the vendor resolved the issue pertaining to each review comment. Responses such as "acknowledged" or "noted" are not acceptable.
 - 3) Resubmittals that do not comply with this requirement may be rejected and returned without review.
 - 4) Supplier shall be allowed no extensions of any kind to any part of their contract due to the rejection of non-compliant submittals.
 - 5) Submittal-review comments not addressed by the Supplier in resubmittals shall continue to apply, whether restated or not in subsequent reviews, until adequately addressed by the Supplier to the satisfaction of the reviewing and approving authority.
 - c. Any resubmittal that does not contain responses to the Engineer's previous comments shall be returned for Revision and Resubmittal. No further review by the Engineer will be performed until a response for previous comments has been received.

4. Resubmittal timeframe:
 - a. Supplier shall provide resubmittal within 15 days.
 - b. When a resubmittal cannot be returned within the specified period, Supplier shall notify Engineer in writing.
5. Review costs:
 - a. Costs incurred by City as a result of additional reviews of a particular submittal after the second time it has been reviewed shall be borne by Supplier.
 - b. Reimbursement to City will be made by deducting such costs from Supplier's subsequent progress payments.

1.09 SUPPLIER'S PROFESSIONAL ENGINEER (P.E.) CERTIFICATION FORM

- A. Submit a completed Supplier's P.E. Certification Form, provided in this Section, to comply with technical sections requirement for a professional engineer's certification from an engineer licensed in the State where the project is located.

PART 2 PRODUCTS

Not Used.

PART 3 EXECUTION

Not Used.

END OF SECTION

APPENDIX A
SUPPLIER SUBMITTAL TRANSMITTAL FORM

**DOCUMENT 01330
SUPPLIER SUBMITTAL TRANSMITTAL FORM**

City: Click here to enter text. **Date:** MM/DD/YYYY
Supplier: Click here to enter text. **Project No.:** XXXXX.XX
Project Name: Click here to enter text. **Submittal Number:** 000
Submittal Title: Click here to enter text.
To: Click here to enter text.
From: Click here to enter text. Click here to enter text.
Click here to enter text. Click here to enter text.

Specification No. and Subject of Submittal / Equipment Vendor			
Spec ##:	Spec ##.	Subject:	Click here to enter text.
Authored By:	Click here to enter text.	Date Submitted:	XX/XX/XXXX

Submittal Response	
Check Either (A) or (B):	
<input type="checkbox"/>	(A) We have verified that the equipment or material contained in this submittal meets all the requirements specified in the project manual or shown on the contract drawings with no exceptions.
<input type="checkbox"/>	(B) We have verified that the equipment or material contained in this submittal meets all the requirements specified in the project manual or shown on the contract drawings except for the following deviations (list deviations):
Certification Statement: By this submittal, I hereby represent that I have determined and verified all field measurements, field construction criteria, materials, dimensions, catalog numbers and similar data, and I have checked and coordinated each item with other applicable, approved shop drawings and all Contract requirements.	
General Supplier's Reviewer's Signature:	
Printed Name:	
In the event Supplier believes the Submittal response does or will cause a change to the requirements of the Contract, Supplier shall immediately give written notice stating that Supplier considers the response to be a Change Order.	
Firm:	Click here to enter text. Signature: Date Returned: XX/XX/XXXX

PM/CM Office Use	
Date Received GC to PM/CM:	
Date Received PM/CM to Reviewer:	
Date Received Reviewer to PM/CM:	
Date Sent PM/CM to GC:	

APPENDIX B
SUPPLIER'S P.E. CERTIFICATION FORM

**DOCUMENT 01330
SUPPLIER'S P.E. CERTIFICATION FORM**

City: Click here to enter text. **Date:** MM/DD/YYYY.
Supplier: Click here to enter text. **Registration State:** Click here to enter text.
Project Name: Click here to enter text. **Project No.:** 00000.00.
Responsibilities: Click here to enter text.
Spec Section: Click here to enter text.

Statement of Certification	
<p>The undersigned hereby certifies that he/she is a professional engineer registered in the State of _____ and that he/she has been employed by _____</p> <p>The undersigned further certifies that he/she has performed the said design in conformance with all applicable local, state, and federal codes, rules, and regulations; and, that his/her signature and P.E. stamp have been affixed to all calculation and drawings used in, and resulting from, the design.</p> <p>The undersigned hereby agrees to make all original design drawings and calculations available to: _____</p> <p><u>Click here to enter text.</u></p>	
<p>(Name of City, or City's representative within 7 days of receiving a written request by the City.)</p>	
<p>Prof. Engineer Signature: _____</p>	<p>Date: _____</p>
<p>Printed Name: _____</p>	<p>Company Name: _____</p>
<p>Supplier's Signature: _____</p>	<p>Date: _____</p>
<p>Printed Name: _____</p>	

SECTION 01410

REGULATORY REQUIREMENTS

PART 1 GENERAL

1.01 SUMMARY

- A. Section includes: Regulatory authorities and codes.

1.02 AUTHORITIES HAVING JURISDICTION

- A. Building Department: City of Santa Rosa.
- B. Fire Department: City of Santa Rosa.

1.03 APPLICABLE CODES

- A. International Code Council (ICC):
 - 1. Building code:
 - a. International Building Code (IBC), 2012.
 - b. International Existing Building Code (IEBC), 2012.
 - 2. Electrical code:
 - a. National Fire Protection Association (NFPA), NFPA 70: National Electrical Code (NEC), 2014.
 - 3. Energy code:
 - a. International Energy Conservation Code (IECC), 2012.
 - 4. Fire code:
 - a. International Fire Code (IFC), 2012.
 - 5. Mechanical code:
 - a. International Mechanical Code (IMC), 2012.
- B. California Code of Regulations (CCR), California Building Standards Code, CCR Title 24:
 - 1. Building code:
 - a. California Building Code (CBC), Title 24, Part 2 – 2013.
 - 2. Electrical code:
 - a. California Electrical Code (CEC), Title 24, Part 3 – 2013.
 - 3. Existing building code:
 - a. California Existing Building Code (CEBC), Title 24, Part 10 – 2013.
 - 4. Fire code:
 - a. California Fire Code (CFC), Title 24, Part 9 – 2013.
 - 5. Mechanical code:
 - a. California Mechanical Code (CMC), Title 24, Part 4 – 2013.
 - 6. Plumbing code:
 - a. California Plumbing Code (CPC), Title 24, Part 5 – 2013.
 - 7. Energy code:
 - a. California Energy Code (CEC), Title 24, Part 6 – 2013.

PART 2 PRODUCTS

Not Used.

PART 3 EXECUTION

Not Used.

END OF SECTION

SECTION 01450
QUALITY CONTROL

PART 1 GENERAL

1.01 SUMMARY

- A. Section includes:
 - 1. Quality control and control of installation.
 - 2. Tolerances.
 - 3. References.
 - 4. Mock-up requirements.
 - 5. Authority and duties of City's representative or inspector.
 - 6. Sampling and testing.
 - 7. Testing and inspection services.
 - 8. Supplier's responsibilities.

- B. Related sections:
 - 1. The Contract Documents are complementary; what is called for by one is as binding as if called for by all.
 - 2. It is the Supplier's responsibility for scheduling and coordinating the Work of subcontractors, vendors, and other individuals or entities performing or furnishing any of Supplier's Work.
 - 3. The following Sections are related to the Work described in this Section. This list of Related Sections is provided for convenience only and is not intended to excuse or otherwise diminish the duty of the Supplier to see that the completed Work complies accurately with the Contract Documents:
 - a. Section 11289 - Low-Pressure, High-Output UV Disinfection System.

1.02 QUALITY CONTROL AND CONTROL OF INSTALLATION

- A. Monitor quality control over vendors, manufacturers, products, services, site conditions, and workmanship to produce Work of specified quality.

- B. Comply with manufacturers' instructions, including each step in sequence.

- C. When manufacturers' instructions conflict with Contract Documents, request clarification from Engineer before proceeding.

- D. Comply with specified standards as minimum quality for the Work, except where more stringent tolerances, codes, or specified requirements indicate higher standards or more precise workmanship.

- E. Perform Work by persons qualified to produce required and specified quality.

- F. Verify field measurements are as indicated on Shop Drawings or as instructed by manufacturer.

- G. Secure products in place with positive anchorage devices designed and sized to withstand stresses, vibration, physical distortion, or disfigurement.
- H. When specified, products will be tested and inspected either at point of origin or at Work site:
 - 1. Notify Engineer in writing well in advance of when products will be ready for testing and inspection at point of origin.
 - 2. Do not construe that satisfactory tests and inspections at point of origin is final acceptance of products. Satisfactory tests or inspections at point of origin do not preclude retesting or re-inspection at Work site.
- I. Do not ship products that require testing and inspection at point of origin prior to testing and inspection.

1.03 TOLERANCES

- A. Monitor fabrication and installation tolerance control of products to produce acceptable Work. Do not permit tolerances to accumulate.
- B. Comply with manufacturers' tolerances. When Manufacturers' tolerances conflict with Contract Documents, request clarification from Engineer before proceeding.
- C. Adjust products to appropriate dimensions; position before securing products in place.

1.04 REFERENCES

- A. American Society for Testing and Materials (ASTM): E 329 - Standard for Agencies Engaged in the Testing and/or Inspection of Materials Used in Construction.
- B. For products or workmanship specified by association, trade, or other consensus standards, comply with requirements of standard, except when more rigid requirements are specified or are required by applicable codes.
- C. Conform to reference standard by date of issue current on date of Contract Documents, except where specific date is established by code.
- D. Obtain copies of standards where required by product specification sections.
- E. When specified reference standards conflict with Contract Documents, request clarification from Engineer before proceeding.

1.05 MOCK-UP REQUIREMENTS

- A. Tests will be performed under provisions identified in this Section and identified in respective product specification sections.
- B. Assemble and erect specified items with specified attachment and anchorage devices, flashings, seals, and finishes.

- C. Accepted mock-ups shall be comparison standard for remaining Work.
- D. Where mock-up has been accepted by Engineer and is specified in product specification sections to be removed, remove mock-up and clear area when directed to do so by Engineer.

1.06 AUTHORITY AND DUTIES OF CITY'S REPRESENTATIVE OR INSPECTOR

- A. City's Project Representative employed or retained by City is authorized to inspect the Work.
- B. Inspections may extend to entire or part of the Work and to preparation, fabrication, and manufacture of products for the Work.
- C. Deficiencies or defects in the Work that have been observed will be called to Supplier's attention.
- D. Inspector will not:
 - 1. Alter or waive provisions of Contract Documents.
 - 2. Inspect Supplier's means, methods, techniques, sequences, or procedures for construction.
 - 3. Accept portions of the Work, issue instructions contrary to intent of Contract Documents, or act as foreman for Supplier; supervise, control, or direct Supplier's safety precautions or programs; or inspect for safety conditions on Work site, or of persons thereon, whether Supplier's employees or others.
- E. Inspector will:
 - 1. Conduct on-site observations of the Work in progress to assist Engineer in determining when the Work is, in general, proceeding in accordance with Contract Documents.
 - 2. Report to Engineer whenever Inspector believes that Work is faulty, defective, does not conform to Contract Documents, or has been damaged; or whenever there is defective material or equipment; or whenever Inspector believes the Work should be uncovered for observation or requires special procedures.

1.07 SAMPLING AND TESTING

- A. General:
 - 1. Prior to delivery and incorporation in the Work, submit listing of sources of materials, when specified in sections where materials are specified.
 - 2. When specified in sections where products are specified:
 - a. Submit sufficient quantities of representative samples of character and quality required of materials to be used in the Work for testing or examination.
 - b. Test materials in accordance with standards of national technical organizations.
- B. Sampling:
 - 1. Furnish specimens of materials when requested.
 - 2. Do not use materials that are required to be tested until testing indicates satisfactory compliance with specified requirements.

3. Specimens of materials will be taken for testing whenever necessary to determine quality of material.
4. Assist Engineer in preparation of test specimens at site of Work, such as soil samples and concrete test cylinders.

1.08 TESTING AND INSPECTION SERVICES

- A. Supplier will employ and pay for specified services of an independent firm to perform Supplier quality-control testing as required in the technical specifications for various work and materials.
- B. City will employ and pay for specified services of an "City's independent testing firm" to perform testing and inspection as required in the technical specifications for various work and materials, or stipulated in Section 01455 to confirm Supplier's compliance with Contract Documents:
 1. If Engineer or City's independent testing firm is not properly certified to perform specialty inspections required by the building department, City will employ and pay for a quality specialty-inspection firm to perform required testing and inspection.
- C. The City's independent testing firm will perform tests, inspections, and other services specified in individual specification sections as required by City and requested by the Engineer.
- D. The qualifications of laboratory that will perform the testing, contracted by the City or by the Supplier, shall be as follows:
 1. Has authorization to operate in the State where the project is located.
 2. Meets "Recommended Requirements for Independent Laboratory Qualification," published by American Council of Independent Laboratories.
 3. Meets requirements of ASTM E 329.
 4. Laboratory Staff: Maintain full-time specialist on staff to review services.
 5. Testing Equipment: Calibrated at reasonable intervals with devices of accuracy traceable to National Bureau of Standards (NBS) or accepted values of natural physical constants.
 6. Will submit copy of report of inspection of facilities made by Materials Reference Laboratory of NBS during most recent tour of inspection, with memorandum of remedies of deficiencies reported by inspection.
- E. Testing, inspections and source quality control may occur on or off project site. Perform off-site testing inspections and source quality control as required by Engineer or City.
- F. Reports will be submitted by City's independent testing firm to Engineer, Supplier, and City in triplicate, indicating observations and results of tests, and indicating compliance or non-compliance with Contract Documents. Each report shall include:
 1. Date issued.
 2. Project title and number.
 3. Testing laboratory's name, address, and telephone number.
 4. Name and signature of laboratory inspector.
 5. Date and time of sampling or inspection.
 6. Record of temperature and weather conditions.
 7. Date of test.

8. Identification of product and specification section.
 9. Location of sample or test in project.
 10. Type of inspection or test.
 11. Results of tests and compliance with Contract Documents.
 12. Interpretation of test results, when requested by Engineer.
- G. Supplier shall cooperate with City's independent testing firm, furnish samples of materials, design mix, equipment, tools, storage, safe access, and assistance by incidental labor as requested:
1. Notify Engineer and City's independent testing firm 48 hours prior to expected time for operations requiring testing.
 2. Make arrangements with City's independent testing firm and pay for additional samples and tests required for Supplier's use.
- H. Limitations of authority of testing Laboratory: City's independent testing firm or Laboratory is not authorized to:
1. Agency or laboratory may not release, revoke, alter, or enlarge on requirements of Contract Documents.
 2. Agency or laboratory may not approve or accept any portion of the Work.
 3. Agency or laboratory may not assume duties of Supplier.
 4. Agency or laboratory has no authority to stop the Work.
- I. Testing and employment of a City's independent testing firm or laboratory shall not relieve Supplier of obligation to perform Work in accordance with requirements of Contract Documents.
- J. Re-testing or re-inspection required because of non-conformance to specified requirements shall be performed by same City's independent testing firm on instructions by Engineer. Payment for re-testing or re-inspection will be charged to Supplier by deducting testing charges from Contract Sum/Price.
- K. The City's independent testing firm responsibilities will include:
1. Test samples of mixes submitted by Supplier.
 2. Provide qualified personnel at site. Cooperate with Engineer and Supplier in performance of services.
 3. Perform specified sampling and testing of products in accordance with specified standards.
 4. Ascertain compliance of materials and mixes with requirements of Contract Documents.
 5. Promptly notify Engineer and Supplier of observed irregularities or non-conformance of Work or products.
 6. Perform additional tests required by Engineer.
 7. Attend preconstruction meetings and progress meetings.
- L. City's independent testing firm individual test reports: After each test, City's independent testing firm shall promptly submit electronically, and also 3 hard copies of report to Engineer and to Supplier. When requested by Engineer, the City's independent testing firm will provide interpretation of test results. Include the following:
1. Date issued.
 2. Project title and number.
 3. Name of inspector.

4. Date and time of sampling or inspection.
 5. Identification of product and specifications section.
 6. Location in project.
 7. Type of inspection or test.
 8. Date of test.
 9. Certified test results stamped and signed by a registered Engineer in the State where the Work is to be installed.
 10. Summary of conformance with Contract Documents.
- M. City's independent testing firm shall provide a monthly report of certification to identify all work performed for special inspections and other contract requirements on this project. At a minimum, the certified monthly report shall include, but not be limited to:
1. Results of testing.
 2. Testing logs.
 3. Outstanding deficiencies.
 4. Various statistical data.
 5. Testing curves (up to 4 types) as required by the Engineer.

1.09 SUPPLIER'S RESPONSIBILITIES

- A. Cooperate with City's independent testing firm or laboratory personnel and provide access to construction and manufacturing operations.
- B. Secure and deliver to City's independent testing firm or laboratory adequate quantities of representative samples of materials proposed to be used and that require testing.
- C. Provide to City's independent testing firm or laboratory and Engineer preliminary mix design proposed to be used for concrete and other materials mixes that require control by testing laboratory.
- D. Furnish electronically, and also 5 hard copies of product test reports.
- E. Furnish incidental labor and facilities:
 1. To provide access to construction to be tested.
 2. To obtain and handle samples at Work site or at source of product to be tested.
 3. To facilitate inspections and tests.
 4. For storage and curing of test samples.
- F. Notify City's independent testing firm or laboratory 48 hours in advance of when observations, inspections, and testing are needed for laboratory to schedule and perform in accordance with their notice of response time.

PART 2 PRODUCTS

Not Used.

PART 3 EXECUTION

Not Used.

END OF SECTION

SECTION 01600
PRODUCT REQUIREMENTS

PART 1 GENERAL

1.01 SUMMARY

- A. Section includes: Product requirements; product selection; product options and substitutions; quality assurance; delivery, handling, and storage; and Supplier's instructions.
- B. Related sections:
 - 1. Section 01330 - Submittal Procedures.
 - 2. Section 01610 - Project Design Criteria.
 - 3. Section 01612 - Seismic Design Criteria.
 - 4. Section 01756 - Commissioning and Process Start-up.
 - 5. Section 01782 - Operation and Maintenance Data.
 - 6. Section 11289 - Low-Pressure, High Output Ultraviolet Disinfection System.

1.02 DEFINITIONS

- A. Products: Inclusive of material, equipment, systems, shop fabrications, source quality control.

1.03 REFERENCES

- A. American National Standards Institute (ANSI).
- B. NSF International (NSF):
 - 1. 61 - Drinking Water System Components.
 - 2. 372 - Drinking Water System Components – Lead Content.

1.04 PRODUCT REQUIREMENTS

- A. Comply with Specifications and referenced standards as minimum requirements.
- B. Product design as specified in Section 01612:
 - 1. Provide equipment and parts that are suitable for stresses, which may occur during fabrication, transportation, erection, and operation.
 - 2. Calculations shall be signed and stamped by a civil or structural engineer registered to practice in the state where the Project is located.
- C. Provide identical products when products are required in quantity.
- D. Provide products with interchangeable parts whenever possible.
- E. Provide equipment that has not been in service prior to delivery, except as required by tests.

- F. Require each equipment Supplier to have maintenance facilities meeting the following requirements:
 - 1. Minimum 3 years operational experience.
 - 2. Location within continental United States.
 - 3. Equipment and tools capable of making repairs.
 - 4. Staff qualified to make repairs.
 - 5. Inventory of maintenance spare parts.

- G. Material requirements:
 - 1. Materials: Provide corrosion resistance suitable for project conditions as specified in Section 01610.
 - 2. Dissimilar metals: Separate contacting surfaces with dielectric material.

PART 2 PRODUCTS

2.01 PRODUCT SELECTION

- A. When products are specified by standard or specification designations of technical societies, organizations, or associations only, provide products that meet or exceed reference standard and Specifications.

- B. When products are specified with names of Suppliers but no model numbers or catalog designations, provide:
 - 1. Products by one of named Suppliers that meet or exceed Specifications.
 - 2. Engineer deemed "or equal" evidenced by an approved shop drawing or other written communication.

- C. When products are specified with names of Suppliers and model numbers or catalog designations, provide:
 - 1. Products with model numbers or catalog designations by one of named Suppliers.

- D. When products are specified with names of Suppliers, but with brand or trade names, model numbers, or catalog designations by one Supplier only, provide:
 - 1. Products specified by brand or trade name, model number, or catalog designation.
 - 2. Products by one of named Suppliers proven in accordance with requirements for or equals to meet or exceed quality, appearance and performance of specified brand or trade name, model number, or catalog designation.

- E. When Products are specified with only one Supplier followed by "or Equal," provide:
 - 1. Products meeting or exceeding Specifications by specified Supplier.

2.02 SUBSTITUTIONS

- A. Formal substitution request procedure:
 - 1. Submit a written formal substitution request to Engineer for each proposed substitution within 30 days of effective date of Contract.
 - 2. Engineer will return initial opinion and request for additional information within 30 days.
 - 3. Engineer will notify in writing of decision to accept or reject the substitution request within 30 days of receiving required information.

- B. Formal substitution request contents:
1. Provide Substitution Request Form as specified in this Section.
 2. Supplier's literature including:
 - a. Supplier's name and address.
 - b. Product name.
 - c. Product description.
 - d. Reference standards.
 - e. Certified performance and test data.
 - f. Operation and maintenance data.
 3. Samples, if applicable.
 4. Shop drawings, if applicable.
 5. Reference projects where the product has been successfully used:
 - a. Name and address of project.
 - b. Year of installation.
 - c. Year placed in operation.
 - d. Name of product installed.
 - e. Point of contact: Name and phone number.
 6. Itemized comparison of the proposed substitution with product specified including a list of significant variations:
 - a. Design features.
 - b. Design dimensions.
 - c. Installation requirements.
 - d. Operations and maintenance requirements.
 7. Define impacts:
 - a. Impacts to construction schedule.
 - b. Impacts to other contracts.
 - c. Impacts to other work or products.
 - d. Impact to Contract Sum:
 - 1) Do not include costs under separate contracts.
 - 2) Do not include Engineer's costs for redesign or revision of Contract Documents.
 - 3) Required license fees or royalties.
 - e. Availability of maintenance services and sources of replacement materials.
 8. Supplier represents the following:
 - a. Supplier will pay associated costs for the Engineer to evaluate the substitution.
 - b. Supplier bears the burden of proof of the equivalency of the proposed substitution.
 - c. Proposed substitution does not change the design intent and will have equal performance to the specified product.
 - d. Proposed substitution is equal or superior to the specified product.
 - e. Supplier will provide the warranties or bonds that would be provided on the specified product on the proposed substitution, unless City requires a Special Warranty.
 - f. Supplier will coordinate installation of accepted substitution into the Work and will be responsible for the costs to make changes as required to the Work.
 - g. Supplier waives rights to claim additional costs caused by proposed substitution which may subsequently become apparent.

- C. Substitutions will not be considered for acceptance under the following conditions:
 - 1. No formal substitution request is made.
 - 2. The substitution is simply implied or indicated on shop drawings or product data submittals.
 - 3. The formal substitution request is submitted by a supplier.

- D. Substitution requests submitted after the deadline will not be considered unless the following evidence is submitted to the Engineer:
 - 1. Proof that the specified product is unavailable for reasons beyond the control of the Supplier:
 - a. Reasons may include manufacturing discontinued, bankruptcy, labor strikes, or acts of God.
 - b. Supplier placed or attempted to place orders for the specified products within 10 days after the effective date of the Agreement.
 - c. The formal substitution request is submitted to Engineer within 10 days of the Supplier discovering the specified product cannot be obtained.

- E. Engineer's decision on a substitution requests will be final and binding:
 - 1. Approved substitutions will be incorporated into the Contract Documents with a Change Order.
 - 2. Requests for time extensions and additional costs based on submission of, approval of, or rejection of substitutions will not be allowed.

2.03 QUALITY ASSURANCE

- A. Employ entities that meet or exceed specified qualifications to execute the Work.

- B. Inspect conditions before executing subsequent portions of the Work. Accept responsibility for correcting unsatisfactory conditions upon executing subsequent portions of the Work.

- C. Secure products in place with positive anchorage devices designed and sized to withstand stresses, vibration, and racking.

2.04 SHIPMENT, HANDLING, STORAGE, AND PROTECTION

- A. Shipment:
 - 1. Mandatory requirements prior to shipment of equipment:
 - a. Engineer approved shop drawings.
 - b. Engineer approved Supplier's Certificate of Source Testing as specified in Section 01756.
 - c. Submit draft operations and maintenance manuals, as specified in Section 01782.
 - 2. Prepare products for shipment by:
 - a. Tagging or marking products to agree with delivery schedule or shop drawings.
 - b. Including complete packing lists and bills of material with each shipment.
 - c. Packaging products to facilitate handling and protection against damage during transit, handling, and storage.
 - d. Securely attach special instructions for proper field handling, storage, and installation to each piece of equipment before packaging and shipment.

3. Transport products by methods that avoid product damage.
- B. Receiving:
1. Deliver products in undamaged condition in Supplier's unopened containers or packaging.
- C. Handling:
1. Handle equipment in accordance with Supplier's instructions.
 2. Provide equipment and personnel to handle products by methods to prevent soiling or damage.
 3. Upon delivery, promptly inspect shipments:
 - a. Verify compliance with Contract Documents, correct quantities, and undamaged condition of products.
 - b. Acceptance of shipment does not constitute final acceptance of equipment.
- D. Storage:
1. Immediately store and protect products and materials until installed in Work.
 2. Store products with seals and legible labels intact.
 3. Maintain products within temperature and humidity ranges required or recommended by Supplier.
 4. Protect painted surfaces against impact, abrasion, discoloration, and other damage:
 - a. Repaint damaged painted surfaces.
 5. Exterior storage of fabricated products:
 - a. Place on aboveground supports that allow for drainage.
 - b. Cover products subject to deterioration with impervious sheet covering.
 - c. Provide ventilation to prevent condensation under covering.
 6. Store moisture sensitive products in watertight enclosures.
 7. Furnish covered, weather-protected storage structures providing a clean, dry, noncorrosive environment for all mechanical equipment, valves, architectural items, electrical and instrumentation equipment and special equipment to be incorporated into this project:
 - a. Storage of equipment shall be in strict accordance with the "instructions for storage" of each equipment supplier and Supplier including connection of heaters, placing of storage lubricants in equipment, etc.
 - b. The Supplier shall furnish a copy of the Supplier's instructions for storage to the Engineer prior to storage of all equipment and materials.
 8. Store loose granular materials on solid surfaces in well-drained area. Prevent materials mixing with foreign matter. Provide access for inspection.
 9. Payment will not be made for improperly stored equipment and materials.
 10. Provide equipment log including, as a minimum, the equipment identification, date stored, date of inspection/maintenance, date removed from storage, copy of Supplier's recommended storage guidelines, description of inspection/maintenance activities performed, and signature of party performing inspection/maintenance.
- E. Protection after installation:
1. Provide substantial coverings as necessary to protect installed products from damage from traffic and subsequent construction operations:
 - a. Remove covering when no longer needed.

- b. Corroded, damaged, or deteriorated equipment and parts shall be replaced before acceptance of the project.
2. Update equipment log on a monthly basis with description of maintenance activities performed in accordance with the Supplier's recommendation and industry standards and signature of party performing maintenance.

2.05 SPARE PARTS, MAINTENANCE PRODUCTS, AND SPECIAL TOOLS

- A. Provide spare parts, maintenance products, and special tools as required by Specifications.
- B. Box, tag, and clearly mark items.
- C. Store spare parts, maintenance products, and special tools in enclosed, weather-proof, and lighted facility during the construction period:
 1. Supplier is responsible for spare parts and special tools until acceptance by City.
 2. Protect parts subject to deterioration, such as ferrous metal items and electrical components with appropriate lubricants, desiccants, or hermetic sealing.
- D. Spare parts and special tools inventory list, see Appendix A:
 1. Equipment tag number.
 2. Equipment Supplier.
 3. Subassembly component, if appropriate.
 4. Quantity.
 5. Storage location.
- E. Large items:
 1. Weight: Greater than 50 pounds.
 2. Size: Greater than 24 inches wide by 18 inches high by 36 inches long.
 3. Stored individually.
 4. Clearly labeled:
 - a. Equipment tag number.
 - b. Equipment Supplier.
 - c. Subassembly component, if appropriate.
- F. Smaller items:
 1. Weight: Less than 50 pounds.
 2. Size: Less than 24 inches wide by 18 inches high by 36 inches long.
 3. Stored in spare parts box.
 4. Clearly labeled:
 - a. Equipment tag number.
 - b. Equipment Supplier.
 - c. Subassembly component, if appropriate.
- G. Spare parts and special tools box:
 1. Wooden box:
 - a. Size: 24 inches wide by 18 inches high by 36 inches long.
 2. Hinged wooden cover.
 - a. Strap type hinges.
 - b. Locking hasp.
 - c. Spare parts inventory list taped to underside of cover.

3. Coating: As specified in Section 09960.
4. Clearly labeled:
 - a. The words "Spare Parts and/or Special Tools."
 - b. Equipment tag number.
 - c. Equipment Supplier.

PART 3 EXECUTION

3.01 EXAMINATION

- A. Inspect components for shipping damage and conformance to Contract Documents.

3.02 COMMISSIONING

- A. As specified in Section 01756.

3.03 CLOSEOUT ACTIVITIES

- A. City may request advanced delivery of spare parts, maintenance products, and special tools:
 1. Deduct the delivered items from inventory and provide transmittal documentation.
- B. Immediately prior to the date of Substantial Completion, arrange to deliver spare parts, maintenance products, and special tools to City at a location on site chosen by the City:
 1. Provide itemized list of spare parts and special tools that matches the identification tag attached to each item.
 2. City and Engineer will review the inventory and the itemized list to confirm it is complete and in good condition prior to signing for acceptance.

3.04 ATTACHMENTS

- A. Appendix A - Spare Parts, Maintenance Products, and Special Tools Inventory List.
- B. Appendix B - Sample Substitution Request Form.

END OF SECTION

APPENDIX A
SPARE PARTS, MAINTENANCE PRODUCTS, AND SPECIAL TOOLS INVENTORY LIST

City: _____ Date: _____
 Supplier: _____ Project No.: _____
 Project Name: _____

Inventory List				
Spec Number: _____		Spec Title _____		
Equipment Tag No.: _____		Equipment Supplier: _____		
Quantity	Subassembly Component	Description	Supplier's Part Number	Storage Location

APPENDIX B
SUBSTITUTION REQUEST FORM

DOCUMENT 01600(01_60_00)
SUBSTITUTION REQUEST FORM

City: _____ **Date:** _____
Supplier: _____ **Project No.:** _____
Project Name: _____
To: _____ **From:** _____
Re: _____
Contract For: _____
Engineering Project Number: _____ **Substitution Request Number:** _____

Specification Information		
Title:	_____	
Number:	Page:	Article/Paragraph:
_____	_____	_____
Description:	_____	

Proposed Substitution				
Product:	_____			
Supplier:	_____			
Address:	_____	Phone:	_____	
Trade Name:	_____	Model No.:	_____	
Installer:	_____			
Address:	_____	Phone:	_____	
History:	New Product	2-5 years old	5-10 years old	More than 10 years old
Differences between proposed substitution and specified product:				
Point-by-point comparative data and impacts attached – REQUIRED BY ENGINEER				

Reason For Not Providing Specified Item	
Reason:	_____
Similar Installation:	_____
Project:	_____
Address:	_____ Date Installed: _____
City:	_____ Architect: _____
Proposed substitution affects other parts of Work:	
_____ No	_____ Yes, Explain: _____

Benefit to City For Accepting Substitution	
Savings:	_____ (\$)
Proposed substitution changes Contract Time:	
_____ No	_____ Yes (Add) (Deduct) _____ days

Supporting Data Attached	
_____ Drawings	_____ Product Data
_____ Reference Projects	_____ Samples
	_____ Tests
	_____ Reports
	Other: _____

Certifications	
The undersigned certifies:	
<ul style="list-style-type: none"> • Proposed substitution has been fully investigated and determined to be equal or superior in all respects to specified product. • Same warranty will be furnished for proposed substitution as for specified product, unless City requires a Special Warranty. • Same maintenance service and source of replacement parts, as applicable, is available. • Proposed substitution will have no adverse effect on other trades and will not affect or delay progress schedule. • Cost data as stated above is complete. Claims for additional costs related to accepted substitution which may subsequently become apparent are to be waived. • Proposed substitution does not affect dimensions and functional clearances. • Payment will be made for changes to building design, including Engineer design, detailing, and construction costs caused by the substitution. • Coordination, installation, and changes in the Work as necessary for accepted substitution will be complete in all respects. 	

Certifications	
Submitted by:	_____
Signed by:	_____
Firm Name	_____
Firm Address:	_____

Phone:	_____
Attachments:	_____

Engineer's Review And Action	
<input type="checkbox"/>	Substitution accepted - Make submittals in accordance with Specification Section 01330.
<input type="checkbox"/>	Substitution accepted as noted - Make submittals in accordance with Specification Section 01330.
<input type="checkbox"/>	Substitution rejected - Use specified materials.
<input type="checkbox"/>	Substitution Request received too late - Use specified materials.
Signed by:	_____ Date: _____

Additional Comments	
Additional Comments:	
<input type="checkbox"/>	Contractor
<input type="checkbox"/>	Subcontractor
<input type="checkbox"/>	Supplier
<input type="checkbox"/>	Supplier
<input type="checkbox"/>	Engineer
Other:	_____
Comments:	_____

SECTION 01610

PROJECT DESIGN CRITERIA

PART 1 GENERAL

1.01 SUMMARY

- A. Section includes: Project design criteria such as temperature and site elevation.

1.02 PROJECT DESIGN CRITERIA

- A. All equipment and materials for the project are to be suitable for performance in wastewater treatment plant environment and under following conditions:
 - 1. Design temperatures are:
 - a. Outdoor temperatures: - 9 to 43 degrees Celsius.
 - b. Indoor temperatures for the following buildings:
 - 1) Process areas and electrical rooms: 5 to 40 degrees Celsius.
 - 2. Moisture conditions: Defined in individual equipment sections.
 - 3. Site elevation: Approximately 164 feet above mean sea level.
 - 4. Other: Misty, humid environment in the UV facility subject to splashing.

PART 2 PRODUCTS

Not Used.

PART 3 EXECUTION

Not Used.

END OF SECTION

SECTION 01612

SEISMIC DESIGN CRITERIA

PART 1 GENERAL

1.01 SUMMARY

- A. Section includes: Seismic design criteria for the following:
 - 1. Anchorage of mechanical and electrical equipment.
- B. Related sections:
 - 1. Section 01410 - Regulatory Requirements.

1.02 REFERENCES

- A. American Society of Civil Engineers (ASCE):
 - 1. 7-10 - Minimum Design Loads for Buildings and Other Structures.

1.03 SYSTEM DESCRIPTION

- A. Design in accordance with the requirements of the building code as specified in Section 01410.
- B. Design of non-structural components and their connections to structures:
 - 1. Component amplification factor, a_p : In accordance with ASCE 7, Tables 13.5-1 and 13.6-1.
 - 2. Component response modification factor, R_p : In accordance with ASCE 7, Tables 13.5-1 and 13.6-1.
 - 3. Component Importance Factor, I_p :

Table 1: Component Importance Factor, I_p		
Component	Description	I_p
Electrical	Equipment and appurtenances provided and installed under Division 16, 17 and 11.	1.5

- C. Seismic Design Category (SDC).
- D. Seismic Design Category (SDC) for certification of mechanical and electrical equipment as required by ASCE 7:
 - 1. Wastewater Treatment Facility - UV Disinfection Facility
All areas: Seismic Design Category D.
- E. Design requirements: Anchorage of equipment to structures:
 - 1. Do not use friction to resist sliding due to seismic forces. Do not design or provide connections that use friction to resist seismic loads. Resist seismic forces through direct tension and/or shear on anchors and fasteners.
 - 2. Do not use more than 60 percent of the weight of the mechanical and electrical equipment for designing anchors for resisting overturning due to seismic forces.

3. Do not use more than 60 percent of the weight of the tank for resisting overturning due to seismic forces:
 - a. Do not use concrete anchors, flush shells, sleeve anchors, screw anchors, powder-actuated fasteners, or other types of post-installed mechanical anchors.

1.04 SUBMITTALS

- A. Shop drawings and calculations: Complete shop drawings and seismic calculations.
- B. Calculations shall be signed and stamped by a civil or structural engineer licensed in the State where the Project is located.

PART 2 PRODUCTS

Not Used.

PART 3 EXECUTION

Not Used.

END OF SECTION

SECTION 01756

COMMISSIONING AND PROCESS START-UP

PART 1 GENERAL

1.01 SUMMARY

- A. Section includes: Requirements for the Planning, Commissioning, and Process Start-Up Phases for the UV equipment/system and/or facility. See Section 11289 for additional requirements. In this Specification Section, Contractor is the Installation Contractor, to be selected by City at a later date, and Supplier relates to UV Equipment Supplier.
- B. Related sections:
 - 1. Section 01782 - Operation and Maintenance Data.
 - 2. Section 11289 - Low Pressure, High-Output UV Disinfection System.

1.02 DEFINITIONS

- A. Clean Water Facility Testing – Testing of complete facility utilizing clean water for purposes of confirming extended equipment/system operation prior to process start-up.
- B. Commissioning – The process of testing the installation for compliance with contract requirements and demonstrating, through documented verification, that the project has successfully met the Contract Documents requirements and the Project is ready for process start-up.
- C. Component – A basic building block of equipment, subsystems, and systems that requires installation or functional testing but does not have an electrical connection or internal electronics. (Examples: filter effluent piping and manual isolation valves).
- D. Device – A basic building block of equipment, subsystems, and systems that requires installation or functional testing and does have an electrical connection or internal electronics. (Examples: filter level transmitter or water-pump pressure transmitter).
- E. Equipment – An assembly of component(s) and devices(s) that requires installation or functional testing. (Examples: Pump, motor, VFD, Ozone Generator, UV Disinfection System, etc.).
- F. Facility – A grouping of process areas, systems, subsystems, equipment, components, and devices (Examples: treatment plant, pump station, etc.).
- G. Functional Testing – Testing performed on a completed subsystem to demonstrate that equipment/system meets Suppliers' calibration and adjustment requirements and other requirements as specified. Functional testing includes operating equipment/system manually in local, manually in remote (or remote manual), and automatically in remote (in remote auto).

- H. Installation Testing – Testing to demonstrate that subsystem component (piping, power, networks, devices, etc.) is ready and meets the project requirements in advance of functional testing. Installation testing also includes Suppliers’ certification of installation and other requirements as specified to prepare equipment/system for Functional Testing. Also referred to as Field Acceptance Testing.
- I. Instrumentation and Controls Performance Testing – Testing to prove the performance of the Instrumentation Process Control system by operating for an extended time period.
- J. Supplier’s Certificate of Source Testing – When applicable, the form is used during Source Testing for the Supplier to confirm that the applicable source tests have been performed and results conform to the Contract Documents. The form is provided at the end of this Section.
- K. Supplier’s Certificate of Installation and Functionality Compliance – The form is used during Installation Testing and Functional Testing. It is submitted at the end of Functional Testing to confirm that the equipment/system is installed in conformance with the Contract Documents and that it meets the Functional Testing requirements defined in the Contract Documents. The form is provided at the end of this Section.
- L. Phases – The work activities of testing, training, facility commissioning, and process start-up are grouped into the 3 distinct phases as defined in the table below:

Planning Phase	Commissioning Phase	Process Start-Up Phase
<ul style="list-style-type: none"> • City Training Plan and Schedule • Commissioning and Process Start-Up Schedule • Subsystem Testing Plan • Clean Water Facility Testing Plan 	<ul style="list-style-type: none"> • Source Testing • City Training • Installation Testing • Functional Testing • Clean Water Facility Testing • Closeout Documentation 	<ul style="list-style-type: none"> • Process Start-Up • Process Operational Period • Instrumentation and Controls Performance Testing

- M. Process Area – A grouping of systems, subsystems, equipment, components, and devices that divide a facility into functional areas. (Examples: Filter Process Area or Chemical Area).
- N. Process Operational Period – A period of time after completion of the process start-up set aside for final Operational Testing to verify facility performance meets the Contract Document requirements. This period may specifically limit other construction activities.
- O. Product – A system, subsystem, or component.
- P. Process Start-Up – Activities conducted after commissioning that are necessary to place systems or process areas into operational service.

- Q. Source Testing – Quality-control testing conducted at the source or point of assembly to demonstrate components, devices, equipment/systems, and software meet specified performance requirements prior to shipment. Also referred to as factory testing or factory acceptance testing (FAT).
- R. Subsystem – A building block of systems that consists of a grouping of components, devices, and equipment that perform a definable function. (Examples: Filter No. 1 Backwash Subsystem, Sedimentation Basin No. 1 Hoseless Sludge Removal Subsystem).
- S. System – A grouping of subsystems, equipment, components, and devices that perform a definable function. (Examples: Filter No. 1, Sedimentation Basin).

1.03 COMMISSIONING AND START-UP COORDINATOR (CSC)

- A. Installation Contractor shall designate and provide a CSC representative for this project for UV System start-up.
- B. Installation Contractor shall submit summary of the CSC's qualifications within 30 days of NTP:
 - 1. Include description of previous experience as a CSC on similar projects for the designated CSC and a list of references including phone numbers for review and City approval.
- C. Installation Contractor CSC responsibilities include the following:
 - 1. See additional requirements in Section 11289.
 - 2. Be regularly engaged and experienced in all aspects of commissioning and process start-up of water or wastewater pumping and treatment facilities, equipment/systems of similar size, type, and capacity as this project.
 - 3. Provide technical instruction for commissioning and process start-up.
 - 4. Direct the actual facility operation during Commissioning Phase and Process Start-Up Phase.
 - 5. Lead Contractor's efforts relating to testing, training, and process start-up of project facilities.
 - 6. Provide primary interface with Engineer and City for efforts relating to commissioning and process start-up of project facilities.
 - 7. Carefully review the additional testing requirements in the Contract Documents and coordinate with requirements specified in this Section.
- D. Designate and provide CSC assistants, as needed.

1.04 SERVICES OF SUPPLIER'S REPRESENTATIVES

- A. Qualification of Supplier's representative as specified in the Contract Documents technical Sections include the following:
 - 1. Authorized representative of the Supplier, factory trained and experienced in the technical applications, installation, operation, and maintenance of respective equipment/system with full authority by the equipment/system Supplier to issue the certifications required by the Supplier.
 - 2. Competent, experienced technical representative of equipment/system Supplier for assembly, installation, testing guidance, and training.
 - 3. Additional qualifications may be specified in the individual Sections.

4. Submit qualifications of the Supplier's representative no later than 30 days in advance of required observations.
 5. Representative subject to approval by City and Engineer.
 6. No substitute representatives will be allowed until written approval by City and Engineer has been obtained.
- B. Completion of Supplier on-site services: Engineer approval required.
- C. Supplier is responsible for determining the time required to perform the specified services:
1. Minimum times specified in the Contract Documents are estimates.
 2. No additional costs associated with performing the required services will be approved.
 3. Supplier required to schedule services in accordance with the Contractor's project schedule up to and including making multiple trips to project site when there are separate milestones associated with installation of each occurrence of Supplier's equipment.
- D. Supplier's on-site services as specified in the Contract Documents include the following:
1. Assistance during Commissioning Phase and Process Start-Up Phase.
 2. Provide daily copies of Supplier's representatives' field notes and data to Engineer.
 3. Other requirements as specified in the Contract Documents.

1.05 PLANNING PHASE

- A. Overview of Planning Phase:
1. Define approach and timing for Commissioning Phase and Process Start-Up Phase.
- B. City training and schedule:
1. Training outcomes:
 - a. City's operations, maintenance, and engineering staff have the information needed to safely operate, maintain, and repair the equipment/systems provided in the Contract Documents.
 2. Training objectives:
 - a. To instruct personnel in the operation and maintenance of the equipment/system. Instruction shall include step-by-step troubleshooting procedures with all necessary test equipment/system.
 - b. To instruct personnel in the removal, inspection, and cleaning of equipment/system as needed.
 - c. Training tailored to the skills and job classifications of the staff attending the classes (e.g., plant superintendent, treatment plant operator, maintenance technician, electrician, etc.).
 - d. Provide supporting documentation, such as vendor operation and maintenance manuals.
 3. Training schedule:
 - a. Schedule City's staff training within the constraints of their workloads. Those who will participate in this training have existing full-time work assignments, and training is an additional assigned work task, therefore,

scheduling is imperative. City staff work schedules regularly shift, as treatment facilities are typically operated on an around-the-clock basis.

4. Training plan:
 - a. Coordinate and arrange for Supplier's representatives to provide both classroom-based learning and field (hands-on) training, based on training module content and stated learning objectives.
 - b. Conduct classroom training at location designated by City.
 - c. Scope and sequence:
 - 1) Plan and schedule training in the correct sequence to provide prerequisite knowledge and skills to trainees:
 - a) Describe recommended procedures to check/test equipment/system following a corrective maintenance repair.
5. Training scheduling coordination:
 - a. CSC is responsible for the following:
 - 1) Coordinate schedule for training periods with the City's personnel and Supplier's representatives (instructors).
 - b. Complete City training no sooner than 15 calendar days prior to start of process start-up of each system.
6. Training sessions:
 - a. Provide training sessions for equipment/system as specified in the individual equipment/system Section.

C. Commissioning and Process Start-Up Schedule:

1. Commissioning overview:
 - a. Comply with Commissioning and Process Start-Up Roles and Responsibilities Matrix specified at the end of this Section.
2. Submittal due date:
 - a. Submit Commissioning and Process Start-Up Schedule not less than 60 calendar days prior to planned, initial commissioning of each subsystem or system.
3. Schedule requirements:
 - a. Provide detailed schedule of commissioning and process start-up activities including durations and sequencing requirements:
 - 1) Identify the following activities:
 - a) Commissioning Phase:
 - (1) Source Testing.
 - (2) City Training.
 - (3) Installation Testing.
 - (4) Functional Testing.
 - b) Process Start-Up Phase:
 - (1) Process Start-Up.
 - (2) Process Operational Period.
 - (3) Instrumentation and Controls Performance Testing.
 - b. Schedule services to avoid conflict with other on-site testing or other Suppliers' on-site services.
 - c. Verify that conditions necessary to allow successful testing have been met before scheduling services.

- D. Subsystem testing plans:
1. Provide separate testing plans for each individual subsystem and system that include the following:
 - a. Approach to testing including procedures, schedule, and recirculation requirements.
 - b. Test objective: Demonstrate subsystem meets the design requirements as specified in the technical Sections.
 - c. Test descriptions, forms, temporary systems (pumps, piping, etc.), shutdown requirements for existing systems, test forms, test logs, witness forms, and checklists to be used to control and document the required tests.
 - d. Test forms: Include, but not limited to, the following information:
 - 1) Tag and name of equipment/system to be tested.
 - 2) Test date.
 - 3) Names of persons conducting the test.
 - 4) Names of persons witnessing the test, where applicable.
 - 5) Test data.
 - 6) Applicable project requirements.
 - 7) Check-offs for each completed test or test step.
 - 8) Place for signature of person conducting tests and for the witnessing person, as applicable.
 - e. Define start-up sequencing of unit processes:
 - 1) Include testing of alarms, interlocks, permissives, control circuits, capacities, speeds, flows, pressures, vibrations, sound levels, and other parameters.
 - 2) Provide detailed test procedures setting forth step-by-step descriptions of the procedures for systematic testing of equipment/system.
 - 3) Demonstrate proper rotation, alignment, speed, flow, pressure, vibration, sound level, adjustments, and calibration:
 - a) Perform initial checks in the presence of and with the assistance of the Supplier's representative.
 - 4) Demonstrate proper operation of each control-loop function including mechanical, electrical, alarms, local and remote controls, instrumentation, and other equipment/system functions:
 - a) Generate signals with test equipment/system to simulate operating conditions in each control mode.
 2. Engineer approval of test plan is required prior to performing test:
 - a. Revise and update test plans based on review comments, actual progress, or to accommodate changes in the sequence of activities.
 - b. Submit test reports for each phase of testing for each equipment/system.
 - c. Engineer approval of preceding test reports is required prior to start of next test.
 - d. Tests will be rescheduled if test plan is not approved by the required deadline:
 - 1) Contractor is responsible for any resulting delay.
 3. Contractor is responsible to reproduce and distribute final test procedures:
 - a. Provide 3 copies for Engineer.
 4. Tests may commence only after Engineer has received approved test plan copies.

5. Submittals:
 - a. Submit test plans not less than 30 calendar days prior to planned installation testing of subsystem or system.
 - b. Completed Supplier's Certificate of Installation and Functionality Compliance.
 - c. Test procedures and forms: Provide signed-off copy of test forms and test reports upon completion of the test.
 - d. Test reports:
 - 1) Submit preliminary copies within 1 day after testing completion.
 - 2) Submit final copies and report within 14 days after testing completion.

1.06 COMMISSIONING PHASE

- A. Overview of Commissioning Phase:
 1. General:
 - a. UV Supplier will supervise Commissioning Phase and Equipment.
 - b. Include specified Source Testing, City Training, Installation Testing, Functional Testing, Clean Water Facility Testing, and Closeout Documentation required by this Section and the technical Sections.
 2. Contractor responsibilities:
 - a. Prior to testing, verify equipment protective devices and safety devices have been installed, calibrated, and tested.
 - b. Acceptable tests: Demonstrate the equipment/system performance meets the requirements stated in the Contract Documents:
 - 1) When the equipment/system fails to meet the specified requirements, perform additional, more detailed, testing to determine the cause, correct, repair, or replace the causative components and repeat the testing that revealed the deficiency.
- B. Source Testing:
 1. Also referred to as factory testing or factory acceptance testing (FAT).
 2. Test components, devices, and equipment/system for proper performance at point of manufacture or assembly as specified in the technical Sections.
 3. Notify the Engineer in writing when the equipment/system is ready for source inspection and testing.
 4. Source Test Plan:
 - a. As specified in this Section and other technical Sections.
 - b. Source Testing requirements as specified in technical Sections:
 - 1) City/Engineer will witness the testing. Include \$6,000 in Bid to pay City/Engineer travel to facility.
 - 2) Witnessed: 1 City's representative and 1 Engineer's representative present during testing, unless otherwise specified, and provide Supplier's Certificate of Source Testing.
 - c. Prepared by Contractor as a result of discussions and planning emerging from regularly conducted commissioning and process start-up meetings for source tests as specified in the Contract Documents.
 - d. Provide the following items for each Source Test:
 - 1) Purpose and goals of the test.
 - 2) Identification of each item of equipment/system, including system designation, location, tag number, control-loop identifier, etc.
 - 3) Description of the pass/fail criteria that will be used.

- 4) Listing of pertinent reference documents (Contract Documents and industry standards or Sections applicable to the testing).
 - 5) Complete description, including drawings or photographs, of test stands and/or test apparatus.
 - 6) Credentials of test personnel.
 - 7) Descriptions of test equipment to be used, product information, and all appropriate calibration records for the test equipment.
 - 8) Test set-up procedures.
 - 9) Detailed step-by-step test procedures:
 - a) The level of detail shall be sufficient for any witness with a rudimentary technical aptitude to be able to follow the steps and develop confidence that the tests were being performed as planned.
 - b) All steps are significant, and all steps shall be included in the procedures.
 - 10) Sample data logs and data recording forms.
 - 11) Sample computations or analyses with the results in the same format as the final report to demonstrate how data collected will be used to generate final results:
 - a) Complete disclosure of the calculation methodologies.
 - b) Include a sample for each type of computation required for the test and analysis of the results.
 - 12) Detailed outline of the Source Test report.
 - 13) Sample test reports.
 - e. Submit Source Test Plan and forms as specified in the technical Sections:
 - 1) Submit a copy of the Source Test Plan at least 21 days before any scheduled test date.
 - 2) Engineer approval of Source Test Plan required prior to beginning source testing.
 - 3) Schedule the testing after approval of the test procedures submittal.
 - f. Indicate the desired dates for source inspection and testing:
 - 1) Notify the Engineer of the scheduled tests a minimum of 15 days before the date of the test.
5. Test results:
- a. Prepare and submit test results with collected data attached.

C. Training for City Staff:

1. Training instruction format:
 - a. Instructors shall apply adult education best practices, emphasizing learner participation and activity.
 - b. Training delivery may include problem solving, question/answer, hands-on instruction, practice, evaluation/feedback tools, and lecture.
 - c. Visual aids and hands-on practice sessions must support training objectives.
 - d. Lecturing should be less than 30 percent of class time.
 - e. Conduct hands-on instruction according to the following descriptions:
 - 1) Present hands-on demonstrations of at least the following tasks:
 - a) Proper start-up, shutdown, and normal and alternative operating strategies.
 - b) Common corrective maintenance repairs for each group.
 - c) Describe recommended procedures to check/test equipment/system following a corrective maintenance repair.

- 2) Use tools and equipment provided by Supplier to conduct the demonstrations:
 - a) Submit requests for supplemental assistance and facilities with the Contractor's proposed lesson plans.
 - 3) Contractor remains responsible for equipment disassembly or assembly during hands-on training situations involving equipment disassembly or assembly by City's personnel:
 - a) Provide written certification of proper equipment/system operation to Engineer after completion of hands-on training.
2. Class agenda:
 - a. Include the following information in the agenda:
 - 1) Instructor name.
 - 2) Listing of subjects to be discussed.
 - 3) Time estimated for each subject.
 - 4) Allocation of time for City staff to ask questions and discuss the subject matter.
 - 5) List of documentation to be used or provided to support training.
 - b. City may request that particular subjects be emphasized and the agenda be adjusted to accommodate these requests.
 - c. Distribute copies of the agenda to each student at the beginning of each training class.
 3. Number of students:
 - a. Estimated maximum class size: 8 persons:
 - 1) City will determine the actual number of students.
 - 2) Engineer will provide an estimated headcount 1 week prior to the class, so that the instructor can provide the correct number of training aids for students.
 4. Instructor qualifications:
 - a. Provide instructors completely knowledgeable in the equipment/system for which they are training.
 - b. Provide instructors experienced in conducting classes.
 - c. Provide instructor's technical preparation and instructional technology skills and experience.
 - d. Sales representatives are not qualified instructors unless they possess the detailed operating and maintenance knowledge required for proper class instruction.
 - e. If, in the opinion of the City, an appropriately knowledgeable person did not provide the scheduled training, such training shall be rescheduled and repeated with a suitable instructor.
 5. Training aids:
 - a. Instructors are encouraged to use audio-visual devices, P&IDs, models, charts, etc., to increase the transfer of knowledge.
 - b. Instructors shall provide such equipment (televisions, video recorder/player, computer, projectors, screens, easels, etc.), models, charts, etc., for each class.
 - c. Instructor is responsible for confirming with Engineer and City in advance of each class that the classroom will be appropriate for the types of audiovisual equipment to be employed.
 6. Classroom documentation:
 - a. Trainees will keep training materials and documentation after the session.

- b. Operations and maintenance manuals, as specified in technical Sections:
 - 1) Provide a minimum of 2 copies of final Engineer-approved operations and maintenance manuals as specified in Section 01782 for use during the classroom instruction.
 - 2) City reserves the right to delay training for a particular equipment item if the operations and maintenance manuals for that equipment are incomplete, inaccurate, or otherwise unsuitable for use by the City's staff.
 - 3) No contract extensions or extra costs will be allowed for training delays due to operations and maintenance manual submittal delays.
- c. Provide supplemental documentation handouts to support instruction.
- d. Digitally record audio and video of each training session:
 - 1) Include classroom and field instruction with question and answering periods.
 - 2) Engineer approval required for producer of video materials from one of the following options:
 - a) Qualified, professional video-production company.
 - b) Contractor demonstrates satisfactory skill.
 - 3) Record in digital format and recording shall become property of the City:
 - a) Provide audio quality that is not degraded during the recording of the field sessions due to background noise, space, distance, or other factors.
 - 4) Video files shall be file format and delivery medium as directed and approved by City.
 - 5) Provide 2 complete sets of video materials, fully indexed and cataloged with printed labels stating session content and dates recorded.
 - 6) The Contractor shall provide a written release from all claims to the recorded training material produced, if required.
- e. Training modules:
 - 1) Provide a training module for each equipment category.
 - 2) Divide each training module's instructional content into discrete lesson plans.
- f. Lesson plans:
 - 1) Provide performance-based learning objectives.
 - 2) State learning objectives in terms of what the trainees will be able to do at the end of the lesson.
 - 3) Define student conditions of performance and criteria for evaluating instructional success:
 - a) Provide the following information.
 - 4) Instruction lesson plan outlines for each trade:
 - a) Provide specific components and procedures.
 - 5) Minimum requirements:
 - a) Hands-on demonstrations planned for the instructions.
 - b) Cross-reference training aids.
 - c) Planned training strategies such as whiteboard work, instructor questions, and discussion points or other planned classroom or field strategies.
 - d) Attach handouts cross-referenced by section or topic in the lesson plan.
 - e) Indicate duration of outlined training segments.

- 6) Provide maintenance-instruction lesson plans, instrumentation, and electrical aspects:
 - a) Equipment operation:
 - (1) Describe equipment's operating (process) function and system theory.
 - (2) Describe equipment's fundamental operating principles and dynamics.
 - (3) Identify equipment's mechanical, electrical, and electronic components and features.
 - (4) Identify support equipment associated with the operation of subject equipment.
 - (5) Detail the relationship of each piece of equipment or component to the subsystems, systems, and process.
 - (6) Cite hazards associated with the operations, exposure to chemicals associated with the component, or the waste stream handled by the component.
 - (7) Specify appropriate safety precautions, equipment, and procedures to eliminate, reduce, or overcome hazards.
 - b) Detailed component description:
 - (1) Define Preventative Maintenance (PM) inspection procedures required on equipment in operation, spot potential trouble symptoms (anticipate breakdowns), and forecast maintenance requirements (predictive maintenance):
 - (a) Review preventive-maintenance frequency and task-analysis table.
 - (2) Identify each component function and describe in detail.
 - (3) Where applicable, group relative components into subsystems.
 - (4) Identify and describe in detail equipment safety features, and permissive and controls interlocks.
- 7) Provide the following information in equipment troubleshooting lesson plans:
 - a) Define recommended systematic troubleshooting procedures as they relate to specific craft problems.
 - b) Provide component-specific troubleshooting checklists as they relate to specific craft problems.
- 8) Provide the following information in equipment Corrective Maintenance (CM) troubleshooting lesson:
 - a) Describe recommended equipment-preparation requirements as they relate to specific craft problems.
 - b) Identify and describe the use of any special tools required for maintenance of the equipment as they relate to specific craft problems.
 - c) Describe component removal/installation and disassembly/assembly procedures for specific craft repairs.
 - d) Perform at least 2 hands-on demonstrations of common corrective-maintenance repairs:
 - (1) Additional demonstrations may be required by the City.
 - e) Describe recommended measuring instruments and procedures, and provide instruction on interpreting alignment measurements, as appropriate.

7. Class logistics:
 - a. Delivery time minimum: 2 hours.
 - b. Delivery time maximum: 4 hours:
 - 1) Longer time requires Engineer approval.
 - c. Class agenda:
 - 1) Refreshment break: One 10-minute break.
 - 2) Meal break: One 45-minute break, unless otherwise specified.
 - 3) Schedule refreshment breaks and meal breaks to meet the class needs and City work rules.
 - d. Schedule specific sessions:
 - 1) Minimum of 30 days in advance to allow City staffing arrangements to take place.
 - 2) At the times requested by the City, within the period 7 a.m. to 7 p.m. Monday through Friday:
 - a) Times scheduled will be at City's discretion.
 - 3) City approval and confirmation required for session schedules.
 - 4) Provide minimum of 2 sessions for each class, unless otherwise noted:
 - a) The purpose of having multiple sessions on each class is to accommodate the attendance of as many City personnel working different shifts as possible.
8. Distribute Training Evaluation Form following each training session:
 - a. Training Evaluation Form is included in this Section.
 - b. Return completed Training Evaluation Forms to City's designated training coordinator immediately after session is completed.
 - c. Revise training sessions judged "Unsatisfactory" by a majority of attendees:
 - 1) Conduct training sessions again until a satisfactory rating is achieved at no additional cost to City.
9. Submittals:
 - a. Prior to the training session:
 - 1) Instructor qualifications: Due 30 calendar days prior to initial training session.
 - 2) Training course materials: Due 14 calendar days prior to initial training session:
 - a) Training agenda, lesson plan, presentation, and handouts.
 - b) Other audio-visual aids utilized during each training course.
 - c) Format: 2 electronic copies and 3 hard copies organized in notebooks.
 - b. Post-training session:
 - 1) Training course materials: Due 14 calendar days after class completion:
 - a) Video recordings.
 - b) Class attendance sheet.
 - c) Training agenda, final lesson plan, presentation, and handouts.
 - d) Other audio-visual aids utilized during each training course.
 - e) Provide materials for all sessions of the class in a single transmittal.
 - f) Format: 2 electronic copies and 3 hard copies organized in notebooks.

- D. Installation Testing:
1. UV Supplier will supervise subsystem testing according to approved Subsystem Testing Plans.
 2. Initiate the Supplier's Certificate of Installation and Functionality Compliance for all equipment:
 - a. Supplier's Certificate of Installation and Functionality Compliance form is included in this Section.
 - b. Supplier's Certificate of Installation and Functionality Compliance certifies the equipment meets the following requirements:
 - 1) Has been properly installed, adjusted, aligned, and lubricated.
 - 2) Is free of any stresses imposed by connecting piping or anchor bolts.
 - 3) Is able to be operated as necessary for Functional Testing.
 - c. Form shall be submitted after completion of Functional Testing, as specified in this Section.
- E. Functional Testing:
1. UV Supplier will supervise Functional Testing.
 2. Perform subsystem testing according to approved Subsystem Testing Plan.
 3. Notify the Engineer 5 days prior to when the Work is ready for Functional Testing:
 - a. Perform testing in the presence of the Engineer.
 4. Determine Functional Testing durations with City's input:
 - a. Durations will vary depending on the availability of water for testing.
 - b. Target minimum Functional Test duration: 8 hours:
 - 1) Identify equipment/system that cannot be tested for a minimum of 8 hours as specified in technical Sections.
 5. Perform Functional Testing as specified in technical Sections:
 - a. Perform Functional Testing in addition to the other tests specified in the technical Sections.
 - b. Perform Functional Testing to demonstrate that the component equipment functions as an entire system in accordance with the design requirements.
 - c. Perform Functional Testing to demonstrate that the unit process has operated in a manner necessary to demonstrate equipment/system functions manually in local, manually in remote (or remote manual), and automatically in remote (in remote auto).
 - d. Perform testing with Contractor-provided water.
 - e. Repair or replace parts that operate improperly and retest.
 - f. Submit testing results as specified in the technical Sections to the City and Engineer for approval of Functional Testing results.
 6. Provide completed Supplier's Certificate of Installation and Functionality Compliance forms for all equipment:
 - a. Supplier's Certificate of Installation and Functionality Compliance form is included in this Section.
 - b. Supplier's Certificate of Installation and Functionality Compliance certifies the equipment/system meets the following requirements:
 - 1) Is suitable for satisfactory full-time operation under full-load conditions.
 - 2) Operates within the allowable limits for vibration and noise.
 - 3) Electrical and instrumentation requirements:
 - a) Electrical equipment, instrumentation, and control panels are properly installed, calibrated, and functioning.

- b) Electrical Installation Testing is complete, and test results have been approved by the Engineer:
 - (1) Noted deficiencies have been corrected.
 - (2) Relays, circuit breakers, and other protective devices are set.
- c) Control logic for start-up, shutdown, sequencing, interlocks, control, and emergency shutdown has been tested and is properly functioning.
- d) Motor control is calibrated and tested.

F. Clean Water Facility Testing:

- 1. Utilize plant water.
- 2. Do not begin Clean Water Facility Testing until Engineer has approved submittals for Functional Testing requirements.
- 3. Test entire facility with recirculating water supply at the design flow for the largest single process or system train to ensure proper complete facility (equipment/system) hydraulic performance.
- 4. Perform testing in the presence of the Engineer unless such presence is expressly waived in writing.
- 5. The purpose of Clean Water Facility Testing is to confirm extended equipment/system operation prior to process start-up:
 - a. Testing shall occur for a minimum of 7 days with all systems operational to the extent possible.

G. Closeout documentation:

- 1. Submittals:
 - a. Provide records generated during Commissioning Phase and Process Start-Up Phase of Project:
 - 1) Required documents include but are not limited to:
 - a) Training documentation.
 - b) Supplier's Certificate of Source Testing.
 - c) Supplier's Certificate of Installation and Functionality Compliance.
 - d) Daily logs of equipment/system testing identifying tests conducted and outcome.
 - e) Test forms and documentation.
 - f) Functional Testing results.
 - g) Logs of time spent by Supplier's representatives performing services on the job site.
 - h) Equipment lubrication records.
 - i) Electrical phase, voltage, and amperage measurements.
 - j) Insulation resistance measurements.
 - k) Bearing temperature measurements.
 - 2) Data sheets of control-loop testing, including testing and calibration of instrumentation devices and setpoints. Format: 2 electronic copies and 3 hard copies organized in notebooks.
 - 3) Due date: Within 14 calendar days of Substantial Completion.
 - b. Provide Instrumentation and Control Performance Testing reports:
 - 1) Format: 2 electronic copies and 3 hard copies organized in notebooks.
 - 2) Due date: Within 7 calendar days of Instrumentation and Controls Performance testing completion.

PART 2 PRODUCTS

Not Used.

PART 3 EXECUTION

Not Used.

END OF SECTION

SUPPLIER'S CERTIFICATE OF SOURCE TESTING

CITY _____ EQPT/SYSTEM _____
PROJECT NAME _____ EQPT TAG NO. _____
PROJECT NO. _____ EQPT SERIAL NO. _____
SPECIFICATION NO. _____
SPECIFICATION TITLE _____

Comments: _____

I hereby certify Source Testing has been performed on the above-referenced equipment/system as defined in the Contract Documents, and results conform to the Contract Document requirements. Testing data are attached.

Date of Execution: _____, 20____

Supplier: _____

Supplier's Authorized Representative Name (*print*): _____

(Authorized Signature)

If applicable, Witness Name (*print*): _____

(Witness Signature)

**SUPPLIER'S CERTIFICATE OF
INSTALLATION AND FUNCTIONALITY COMPLIANCE**

CITY _____ EQPT/SYSTEM _____
PROJECT NAME _____ EQPT TAG NO. _____
PROJECT NO. _____ EQPT SERIAL NO. _____
SPECIFICATION NO. _____
SPECIFICATION TITLE _____

I hereby certify that the above-referenced equipment/system has been: (Check Applicable)

- Installed in accordance with Supplier's recommendations.
- Inspected, checked, and adjusted.
- Serviced with proper initial lubricants.
- Electrical/instrumentation and mechanical connections meet quality and safety standards.
- All applicable safety equipment has been properly installed.
- Functionally tested.
- System has been performance tested, and meets or exceeds specified performance requirements.

NOTES:

Attach test results with collected data and test report.

Attach written certification report prepared by and signed by the electrical and/or instrumentation subcontractor.

Comments: _____

I, the undersigned Supplier's representative, hereby certify that I am (i) a duly authorized representative of the Supplier, (ii) empowered by the Supplier to inspect, approve, and operate this equipment/system, and (iii) authorized to make recommendations required to ensure that the equipment/system furnished by the Supplier is complete and operational, except as may be otherwise indicated herein. I further certify that all information contained herein is true and accurate.

Date: _____, 20 ____

Supplier: _____

Supplier's Authorized Representative Name (*print*): _____

By Supplier's Authorized Representative: _____
(Authorized Signature)

COMMISSIONING AND PROCESS START-UP ROLES AND RESPONSIBILITIES MATRIX

NO.	TASK	CITY	INSTALLATION CONTRACTOR	ENGINEER
Commissioning Phase				
Source Testing				
1	Source Testing	Review	Lead	Witness, Review
Installation Testing				
2	Electrical Conductor Testing	No Action	Lead	Witness
3	Electrical Field Acceptance Tests	No Action	Lead	Witness
4	Instrument Field Calibration	No Action	Lead	Witness
5	Network Installation Testing	Witness	Lead	Witness
6	Loop Testing	Review	Lead	Witness
7	Pressure Testing	No Action	Lead	Witness
8	Leak Testing	No Action	Lead	Witness
9	Holiday Testing	No Action	Lead	Witness
10	HVAC Testing	No Action	Lead	Witness
11	Motor Electrical Testing	No Action	Lead	Witness
Functional Testing				
12	Network Operational Testing	Witness	Lead	Review
13	Preliminary Run Testing Local/Manual Control	Witness	Lead	Review
14	PCIS Functional Demonstration Testing - Local/Auto Control Testing - Remote/Manual Contact Testing - Alarm Testing - Control Loop Testing	No Action	Lead	Review
15	Subsystem Start-Up and Testing	Witness	Lead	Review
16	Equipment/System Start-Up and Testing	Witness	Lead	Review
17	HVAC Start-Up and Testing	Witness	Lead	Review
18	Corrosion Control Start-Up and Testing	Witness	Lead	Review
19	Wide Area Network Communications Testing	Support	Lead	Witness
20	Supplier's Certificate of Installation and Functionality Compliance	No Action	Lead	Witness, Review
Clean Water Facility Testing				
21	Test Water Management Plan Finalization	Support	Lead	Review
22	Clean Water Facility Testing	Witness	Lead	Witness, Review
Process Start-Up Phase				
Process Start-Up				
23	Commissioning Documentation and Data Review	Review	Support	Lead
24	Start-Up Go/No-Go Decision Criteria	Lead	Support	Review
25	Building and Fire Inspection Compliance Check	No Action	Lead	Witness

NO.	TASK	CITY	INSTALLATION CONTRACTOR	ENGINEER
26	HVAC Functionality Check	No Action	Lead	Witness
27	Start-Up Sequence Review	Support	Lead	Review
28	Temporary Testing Arrangement Finalization	Support	Lead	Support
29	Start-Up Forms Finalization	Support	Lead	Support
30	Operation Testing Plan Finalization	Review	Support	Lead
31	Test Water Management Plan Finalization	Support	Lead	Review
32	System Testing	Support	Lead	Witness
33	Control Loop Tuning and Optimization	Support	Lead	Witness
34	Process Area Start-Ups	Support	Lead	Witness
35	Facility-Wide Start-Up	Support	Lead	Witness
36	Process Control Systems Testing	Support	Lead	Witness
38	HVAC Final Testing, Adjust, and Balancing	Witness	Lead	Witness, Review
Process Operational Period				
39	Operational Testing	Support	Lead	Witness, Review
40	Final Testing Reports	Support	Lead	Review
41	Water Quality Testing and Documentation	Support	Lead	Review
Instrumentation and Control Performance Testing				
42	PCIS Performance Testing	Support	Lead	Review
Legend: Lead: Primarily responsible for organization, coordination, and execution of task, work, product, or result. Support: Assist the lead with organization, coordination, and execution of task, work, product, or result. Witness: Observe and document completion of task, work, product, or result. Review: As necessary to accept task, work, product, result. No Action: Limited or no involvement.				

SECTION 01782

OPERATION AND MAINTENANCE DATA

PART 1 GENERAL

1.01 SUMMARY

- A. Section includes: Preparation and submittal of Operation and Maintenance Manuals.
- B. Related section:
 - 1. Section 11289 - Low-Pressure, High-Output UV Disinfection System.

1.02 SUBMITTALS

- A. Submit Operation and Maintenance Manuals before field quality-control testing and before training of each piece of equipment or system.
- B. Submit 4 Manuals for each piece of equipment or system. Submit Manuals electronically until all comments from City and Engineer have been incorporated. Indicated section and tab divisions on electronic manuals. Final Manuals shall be submitted as a hard-copy and mailed to the City.
- C. Make manuals available at project site for use by construction personnel and City.
- D. Make additions and revisions to the Manuals in accordance with City's review comments.

1.03 OPERATION AND MAINTENANCE MANUALS

- A. Preparation:
 - 1. Provide Operations and Maintenance Manuals in 3-ring binders with rigid covers. Utilize numbered tab sheets to organize information.
 - 2. Provide original and clear text on reproducible non-colored paper.
 - 3. Provide all dimensions in English units.
- B. Contents of Operation and Maintenance Manuals:
 - 1. Refer to Specification Section 11289 for additional requirements. If there is a contradiction between this Section and Section 11289 concerning content, Section 11289 will govern.
 - 2. Cover page: Equipment name, equipment tag number, project name, City's name, appropriate date.
 - 3. Table of Contents: General description of information provided within each tab section.
 - 4. Equipment Summary Form: Completed form in the format shown in Appendix A. The Supplier's standard form will not be acceptable.
 - 5. Lubrication information: Required lubricants and lubrication schedules.
 - 6. Control diagrams:
 - a. Internal and connection wiring, including logic diagrams, wiring diagrams for control panels, ladder logic for computer-based systems, and connections

- between existing systems and new additions, and adjustments such as calibrations and set points for relays, and control or alarm contact settings.
- b. Complete set of 11-inch by 17-inch drawings of the control system.
 - c. Complete set of control schematics.
7. Programming: Copies of all Contractor-furnished programming.
 8. Start-up procedures: Recommendations for installation, adjustment, calibration, and troubleshooting.
 9. Operating procedures:
 - a. Step-by-step procedures for starting, operating, and stopping equipment under specified modes of operation.
 - b. Include safety precautions and emergency operating shutdown instructions.
 10. Preventative maintenance procedures: Recommended steps and schedules for maintaining equipment.
 11. Overhaul instructions: Directions for disassembly, inspection, repair, and reassembly of the equipment; safety precautions; and recommended tolerances, critical bolt torques, and special tools that are required.
 12. Parts list:
 - a. Complete parts list for all equipment being provided.
Catalog data for all products or equipment furnished including generic title and identification number of each component part of equipment:
 - 1) Include bearing manufacturer, model and ball or roller pass frequencies for every bearing.
 13. Spare-parts list: Recommended number of parts to be stored at the site and special storage precautions.
 14. Drawings:
 - a. Exploded view or plan and section views with detailed callouts.
 - b. Complete set of 11-inch by 17-inch drawings of equipment.
 - c. Provide electrical and instrumentation schematic record drawings.
 15. Source (factory) quality control test results: Provide copies of factory test reports as specified in Section 15958 or the equipment section.
 16. Field quality-control test results: After field-testing is completed, insert field-test reports as specified in Section 15958 or the equipment section.
 17. Equipment Summary Form:
 - a. Completed form in the format attached at the end of this Section.
 - b. Insert Equipment Summary Form after the tab sheet of each equipment section.
 - c. The Supplier's standard form will not be acceptable.

PART 2 PRODUCTS

Not Used.

PART 3 EXECUTION

Not Used.

END OF SECTION

APPENDIX A
EQUIPMENT SUMMARY FORM

1. EQUIPMENT ITEM _____
2. SUPPLIER _____
3. EQUIPMENT IDENTIFICATION NUMBER(S) _____
(Maps Equipment Number)
4. LOCATION OF EQUIPMENT _____
5. WEIGHT OF INDIVIDUAL COMPONENTS (OVER 100 POUNDS) _____

NAMEPLATE DATA

Apparent Power or Horsepower _____
Amperage _____
Voltage _____
Service Factor (S.F.) _____
Speed _____
ENC Type _____
Capacity _____
Other _____

7. SUPPLIER'S LOCAL REPRESENTATIVE
Name _____
Address _____
Telephone Number _____
8. MAINTENANCE REQUIREMENTS _____

9. LUBRICANT LIST _____

10. SPARE PARTS (Recommendations) _____

11. COMMENTS _____

SECTION 11289

LOW-PRESSURE, HIGH-OUTPUT ULTRAVIOLET DISINFECTION SYSTEM

PART 1 GENERAL

1.01 SUMMARY

- A. Section includes: Specification for the equipment associated with the Ultraviolet (UV) Disinfection Systems. Furnish all labor, materials, equipment, and appurtenances required to provide an open-channel, gravity-flow, low-pressure, high-output (LPHO) lamps, UV disinfection system complete with automatic cleaning system. The UV system is to be complete and operational with all control and appurtenant equipment as shown on the Drawings and specified herein. UV Disinfection System Supplier (hereafter called SUPPLIER) shall provide installation, start-up, and operator-maintenance training for the UV system as described in this Section. The SUPPLIER shall assist with commissioning and performance testing for the UV system as described in this Section.
- B. Related Sections:
1. The Contract Documents are complementary; what is called for by one is as binding as if called for by all.
 2. It is the CONTRACTOR's responsibility for scheduling and coordinating the Work of subcontractors, suppliers, and other individuals or entities performing or furnishing any of CONTRACTOR's Work.
 3. The following Sections are related to the Work described in this Section. This list of Related Sections is provided for convenience only and is not intended to excuse or otherwise diminish the duty of the CONTRACTOR to see that the completed Work complies accurately with the Installation Contract Document:
 - a. Section 01110 - Summary of Work.
 - b. Section 01330 - Submittal Procedures.
 - c. Section 01756 - Commissioning and Process Start-Up.
 - d. Section 01782 - Operation and Maintenance Data.
 - e. Section 16050 - Common Work Results for Electrical.
 - f. Section 16123 - 600-Volt or Less Wires and Cables.
 - g. Section 16150 - Low Voltage Wire Connections.
 - h. Section 16494 - Low Voltage Fuses.
 - i. Section 17055 - Packaged Control System.
- C. Provide complete UV Disinfection System that meets all the water quality requirements as set forth by the State of California Title 22 water recycling criteria for unrestricted reuse applications, the National Water Research Institute's (NWRI) Ultraviolet Disinfection Guidelines for Drinking Water and Water Reuse (Third Edition, 2012) (referred to herein as the NWRI UV Guidelines), and the specifications in this Section.
- D. NWRI Validation Testing (per the NWRI UV Guidelines) and Final Report (acceptable to the Engineer) for the UV reactor to be installed must be completed at the time of the installation bid. Suppliers listed in Form 1 shall only be accepted.

- E. The minimum UV equipment requirement is specified in Form 1 (at the end of this Section) remains unchanged. Design flow and UV transmittance are revised.

1.02 REFERENCES

- A. National Water Research Institute (NWRI), Ultraviolet Disinfection Guidelines for Drinking Water and Water Reuse, Third Edition, 2012.
- B. United States Environmental Protection Agency (EPA), Ultraviolet Disinfection Guidance Manual (UVDGM). 2006.
- C. California Code of Regulations: Title 22, DIV 4, Chapter 3, Article 1, 60301.
- D. Institute of Electrical and Electronics Engineers (IEEE), Standard 519 - IEEE Recommended Practice and Requirements for Harmonic Control in Electrical Power Systems, 2014.
- E. National Electrical Manufacturers Association (NEMA), NEMA 250 - Enclosures for Electrical Equipment (1,000 V Maximum), 2014.
- F. Underwriters Laboratories, Inc. (UL), UL 508A - Standard for Industrial Control Panels, 2013.

1.03 DEFINITIONS

- A. General: The terms listed below are used in this specification and shall have the following definitions:
 - 1. UV Bank: One or more UV modules that the entire reactor train flow must pass through. Each bank consists of:
 - a. High purity, quartz sleeves (one sleeve per lamp) to protect lamps from direct contact with the wastewater.
 - b. Each UV Bank shall be connected to its ballasts by means of a multi-conductor cable fitted with a waterproof plug.
 - c. UV intensity sensors to provide continuous monitoring of the reactor performance.
 - d. Automatic on-line cleaning system for periodic cleaning of the quartz sleeves.
 - e. Interconnection of electrical and control cabling between the UV lamps, sensors, cleaning mechanism, and the reactor ballast enclosures.
 - 2. UV Channel (synonymous with UV Train): The independent combination of the UV banks, and inlet and outlet level controlling arrangements located in a concrete channel.
 - 3. UV Disinfection Equipment System (synonymous with UV Disinfection System): The combination of all UV channels with associated controls and instrumentation.
 - 4. UV Intensity Control: The use of calibrated UV sensors, meeting the recommendations of the United States Environmental Protection Agency's (USEPA) Ultraviolet Disinfection Guidance Manual (UVDGM) (2006), to continuously monitor UV intensity within the reactor. The measured UV intensity is used to indicate relative lamp output due to effluent quality, lamp aging, fouling, and ballast power settings, and is used as an input for UV dose-pacing algorithm programmed into the UV system's PLC. For some UV systems, the sensor reading is not utilized for dose pacing, the use of the

- sensors to monitor and alarm the combined effect of lamp aging and sleeve fouling can be sufficient.
5. Attenuated Lamp Conditions: Conditions where the lamps are at the end of their guaranteed lives and the quartz sleeves are fouled (i.e., consistent with the Lamp Age Factor and Sleeve Fouling Factor).
 6. Lamp Age Factor: Reduction in available UV output at the end of the UV lamp life, as compared to a new UV lamp after 100 hours burn-in.
 7. Lamp Life: Total guaranteed operational time that the UV lamp can deliver a UV output that is greater than or equal to the Lamp Age Factor.
 8. Normalized Lamp Velocity: Flow velocity across a lamp (in gpm per lamp), calculated by the total expected flow in a UV channel (in gpm) divided by the total number of lamps in only one (1) bank in the channel.
 9. Sleeve Fouling Factor: The sleeve fouling factor is a measure of the sleeve's loss of irradiance over time (expressed as a percentage of the irradiance from a new and clean quartz sleeve). Periodic automatic and manual cleaning of the system is performed to achieve a factor greater than the Sleeve Fouling Factor.
 10. UV Intensity (UVI): The power per unit area passing through an area perpendicular to the direction of propagation. UV intensity is used to describe the magnitude of UV light in a UV reactor or in a bench-scale UV test.
 11. UV Transmittance (UVT): A measure of the fraction of incident light transmitted through the water column. The UVT is the ratio of the light entering the effluent to that exiting the effluent. UVT is represented as a percentage. UVT is typically quantified by spectrophotometric measurement at a wavelength of 253.7 nm using a one-centimeter path length.
 12. UV Module: The basic building block of a UV disinfection system. It is comprised of more than one UV lamp with a common electrical feed and/or cleaning system.
 13. UV Dose:
 - a. Reduction Equivalent Dose (RED): The dose that is assigned to the UV reactor under a given set of operating conditions that is based on Third-Party Reactor Validation Testing. The RED is equivalent to that measured with the collimated-beam apparatus for the same degree of inactivation of the test microorganism. RED is typically reported in millijoules per square centimeter (mJ/cm²).
 - b. Design RED: The RED delivered for a specific log inactivation of the test microorganism at the peak design flow at the design UVT and attenuated lamp conditions. The design RED is used to size the UV Disinfection System.
 14. UV Reactor: An independent combination of single or multiple UV bank(s) in series with a common mode of failure (e.g., electrical, cooling, cleaning system, etc.).
 15. UV Testing, Reports and References:
 - a. Bioassay: A microbiological procedure used to determine the inactivation of a specific microorganism after exposure to UV light through a specific UV reactor.
 - b. Checkpoint Bioassay: A bioassay test conducted on the full-scale UV System to determine disinfection performance. The checkpoint bioassay consists of a limited series of bioassay disinfection tests that attempt to show the statistical equivalency of the full-scale and NWR1 validated reactor performance. The results are documented in a third-party test report.

- c. NWRI validation testing: Testing completed on a full-scale UV reactor per the NWRI UV Guidelines that serves as the basis of design for this UV system. Testing is conducted to develop reactor dose delivery for various operational conditions. A third-party licensed civil engineer in the State of California must perform the testing.
 - d. Hydraulic and Alarm Testing: As specified herein and per Third Party Reactor Validation Testing Guidelines, testing shall be completed to verify that alarm, headloss, and hydraulics specifications are met. To ensure this, tests shall be run at minimum, average, peak and 120 percent of peak flow over the range of channel operating conditions specified herein.
 - e. Performance testing: A 15-day continuous test to demonstrate bacteriological compliance with State of California requirements. Performance testing to be performed by City based upon a testing plan prepared by the Supplier. Testing to be performed after the UV system expansion is completed.
16. Project Manager: SUPPLIER's personnel having a minimum of 5 years of experience in design and execution of wastewater UV systems to utilities.
17. Contractor: The installation contractor selected by City to install the equipment provided by SUPPLIER.

1.04 PROJECT MANAGEMENT AND QUALITY ASSURANCE

- A. The SUPPLIER shall assign a qualified and experienced project manager for the duration of the project from initial selection through start-up. This project manager shall remain the same throughout the duration of the project. Any changes in project management will require approval from the City and Engineer after they review the qualifications of the proposed candidates:
 - 1. The project manager shall act as the main point of communication between City, Engineer, Contractor, and SUPPLIER regarding the administration of the procurement proposal, installation contract, payment requests, interpretations of contract terms and conditions, warranty, technical aspects of the UV Disinfection Equipment System, including design criteria, materials selection, equipment, control systems, and coordination between SUPPLIER and other parties during the design, bidding, shop drawing submission and reviews, RFIs, and scheduling deliveries, field inspections, start-up, and performance testing during construction.

1.05 SYSTEM DESCRIPTION

- A. Provide a UV disinfection system complete with UV Banks, a control system, UV intensity sensors, automatic on-line cleaning system, power distribution system, online UV transmittance analyzer and accessories as specified herein or as required in order to have a complete and functioning system.
- B. Design Criteria:
 - 1. SUPPLIER shall provide UV disinfection equipment which meets the Performance Requirements, specified in this Section, based on the following conditions:
Influent Water Quality: Refer to Table 1 for the design criteria for the Laguna Treatment Plant:

Table 1 UV Design Criteria	
Peak Flow Rate, Million Gallons per day (MGD)	70.0
Average Daily Flow Rate (MGD)	20.0
Design UV Transmittance (%)	61.0
Average UV Transmittance (%)	64.0
Total Suspended Solids (mg/L)	< 5
Min. RED (mJ/cm ²), per NWRI 2012 UV Guidelines	100.3
Redundancy Requirement	1 bank per channel

- a. The UV Disinfection Systems shall meet the design criteria as specified herein and in Form 1:
 - 1) This minimum dose must be based upon the delivered UV dose equation developed based on the Supplier's NWRI 2012 validation testing results. The Engineer can apply the required correction factor to the Supplier's bioassay results based upon the Engineer's analysis of the Validation Testing and site conditions.
 - 2) Hydraulic Constraints:
 - a) SUPPLIER shall specify the maximum water surface elevation at which the UV system can operate (based on Third Party Reactor Validation Testing).
 - b) SUPPLIER shall specify the minimum water surface elevation that must be maintained at all times, in any channel that contains UV lamps that are turned "ON."
 - c) Maximum Acceptable Normalized Lamp Velocity (gpm/lamp): To be specified by Supplier and shall not exceed maximum value proven effective during Third-Party Validation Testing.
 - d) Minimum Acceptable Normalized Lamp Velocity: To be specified by Supplier and shall not be lower than the minimum value proven effective during Third-Party Validation Testing.
 - 3) Minimum Lamp Life: As stated in Form 1.
 - 4) Lamp Age Factor: As stated in Form 1, Maximum Value – 0.90.
 - 5) Sleeve Fouling Factor: As stated in Form 1, Maximum Value – 0.94.
 - 6) The UV sensors employed by Supplier must track the combined intensity loss due to lamp aging and sleeve fouling (attenuated lamp condition).
 - 7) Number of channels: Channel requirement is specified in Form 1.
 - 8) Banks per channel: Banks requirement is specified in Form 1, includes redundant bank.

C. Performance Requirements:

1. The UV disinfection system performance shall be guaranteed by the SUPPLIER to produce an effluent that meets or exceeds the following:
 - a. The ultraviolet disinfection system shall produce an effluent conforming with the following Title 22 discharge permits limits:
 - 1) Total coliform less than 2.2 MPN/100 mL based on a 7-day median:
 - a) Grab samples shall be taken in accordance with the microbiology sampling techniques found in the latest edition of

the Standard Methods for the Examination of Water and Wastewater.

- 2) 5- \log_{10} poliovirus reduction.
 2. Minimum RED:
 - a. Design each UV channel to deliver a minimum MS2 RED of 100 mJ/cm² at the Peak Flow assuming lamps at the end of lamp life, with fouled sleeves, and in an effluent with a UVT of 61 percent.
 3. The power factor shall be 98 percent or greater. Harmonic distortion shall be measured with all new UV banks in all channels at 100 percent rated load in accordance with a general system classification meeting the recommended maximum harmonic distortion levels in IEEE 519-2014 Tables 1, and 2 at the Point of Common Coupling (PCC). The PCC is defined as the line side of one Power Distribution Center (PDC). The short-circuit current (I_{SC}) for the Laguna Treatment Plant at the PCC is 50,000 amps at 480 volts. Utilize the load of the entire UV system for calculating the short circuit to demand load ratio.
 4. The requirements stated in Form 1 are minimum requirements. If the UV SUPPLIER determines more equipment is needed then the UV SUPPLIER must provide the additional equipment to meet the performance requirement.
- D. The SUPPLIER shall review the environmental conditions of Section 01610. The proposed UV channels shall be outdoors and the electrical enclosures shall be located either indoors or outdoors.
- E. Facility Constraints: All components of the UV system must fit within the footprint as shown in the Drawings, including flow split between UV channels and proper approach and exit lengths, electrical equipment, and reasonable operations and maintenance access.

1.06 SUBMITTALS

- A. Product Data and Shop Drawings: Equipment SUPPLIER shall submit, per Section 01330, the following:
1. Product data, including, but not limited to, the following:
 - a. Complete description in sufficient detail to permit an item-by-item comparison with the Specifications.
 - b. Descriptive information including catalog cuts and SUPPLIER's specifications for all components.
 - c. Written field electrical termination requirements and instructions as required for the Contractor to install a complete and operational system.
 - d. Sources for replacement lamps.
 - e. Third Party Reactor Validation Testing results and corresponding Engineering Report(s).
 - f. Number of lamps per module.
 - g. Number of modules per bank.
 - h. Total number of UV lamps.
 2. General Shop drawing submittal including, but not limited to:
 - a. Details of the UV Module/Bank, ballast enclosure, power distribution system with transformers as required, and control system.
 - b. Dimensions and installation requirements.
 - c. Information on the channel configuration, including but not limited to: widths, depths, lengths, and any other items necessary to confirm the proposed system will fit into the proposed UV channels.

3. Electrical data and shop drawings per DIVISIONS 16 and 17, including but not limited to 16050 and 17055 requirements:
 - a. Electrical Shop Drawings including but not limited to:
 - 1) Front exterior and interior panel layout drawings with bill of materials for all electrical and control panels. Coordinate with DIVISIONS 16 and 17, including but not limited to 16050 and 17055 requirements.
 - 2) Control schematics with wire numbers per DIVISIONS 16 and 17, including but not limited to 16050 and 17055 requirements.
 - 3) Detailed interface and interconnection drawings that indicate all UV system and external component and equipment connections.
 - 4) Detailed electrical wiring diagrams as required for the Contractor to install a complete operational system. Electrical wiring diagrams shall include, but not be limited to:
 - a) Source power feeder conductor quantities and sizes.
 - b) Control wiring quantities and sizes.
 - c) Signal cable quantities and sizes.
 - d) Power (kW), power factor and apparent power (kVA) for each UV Bank.
 - e) Master UV PLC power requirements.
 - f) Cut sheets for each electrical power and control device.
4. Instrumentation and Controls data and shop drawings per Section 17055, with requirements including but not limited to:
 - a. Loop drawings.
 - b. Control philosophy narrative with integration of the Third-Party Reactor Validation Testing results, including the use of the sensors to monitor and alarm the combined effect of lamp aging and sleeve fouling and/or the use of the sensors to continuously monitor UV dose based on inputs of flow, UV sensor intensity, and UV transmittance (UVT).
 - c. Provide system block diagram complete with all inter-equipment wiring and conduit requirements.
 - d. Electronic copy on a CD-ROM of the UV PLC system program.
 - e. Electronic copy on a CD-ROM of the HMI screens and program.
 - f. Systems must be supplied with PLCs or HMIs per Sections 17055.
 - g. Detailed memory map of data to be transferred from or to the Plant SCADA system.
5. List of spare parts to be provided by SUPPLIER.

B. Operation and Maintenance Manuals:

1. UV equipment SUPPLIER shall submit operation and maintenance manuals in accordance with Section 01782:
 - a. In addition to the requirements listed in the above referenced Section, the Operation and Maintenance Manuals shall include:
 - 1) Name, address, and telephone number of nearest SUPPLIER and spare parts warehouse.
 - 2) Procedure for calibration of duty UV intensity sensors.
 - 3) Special tools required for operation and maintenance.
 - 4) Reproducible prints of the Contract diagrams, schematics, and installation drawings for electrical and instrumentation work.
2. The ENGINEER will not approve an equipment unit before its manual has been accepted.

3. UV equipment SUPPLIER's copy of complete manuals shall be available at the site of the work for use by field personnel and ENGINEER during Hydraulic and Alarm Testing, and Performance Testing of equipment.
4. Step by step instructions for operation and maintenance of all equipment provided by SUPPLIER.

C. Quality Certification:

1. SUPPLIER shall submit Engineering Report of the proposed UV Disinfection System, including:
 - a. All raw data used to justify the conclusions of the Third-Party Reactor Validation Testing.
 - b. Test reactor configuration including tested parameters (e.g., flow rates, UV transmittance, number of reactors/lamps in operation, and type of water tested).
 - c. Collimated beam results.
 - d. Reactor validation results with regard to inactivation of the test organism.
 - e. Test results from headloss testing.
 - f. Recommended normalized lamp velocity range (flow/lamp) to meet the required Design RED.
 - g. Delivered RED equation developed based on SUPPLIER's Third- Party Reactor Validation Testing.
2. Hydraulic calculations demonstrating compliance with the hydraulic constraints specified herein.
3. Representative harmonic analysis calculations and reports for both voltage and current at the point of common coupling, defined as the input terminals to the power distribution center. Certification that voltage and current harmonic distortion levels are within IEEE 519 Standard limits at the point of common coupling when powered from utility power supply in accordance with Article 1.05.D.3.
4. SUPPLIER's UV equipment warranty including lamps, ballasts, quartz sleeves, wipers, and UV sensors, as specified herein.
5. SUPPLIER's performance warranty as specified herein.
6. Documentation of the successful completion and results of the Underwriter's Laboratory (UL) or equivalent testing shall be provided.
7. Initial Performance Test protocol to fulfill requirements outlined herein.

D. Closeout Submittals:

1. Written certification of proper UV system installation as outlined in Article 3.02, B herein.
2. Two copies of all UV PLC, operator interface, and other programs required for the maintenance of the UV system in native format on CD-ROM.

E. Other Qualification Requirement Submittals:

1. A statement listing any deviations or exceptions taken to these specifications. Include specification reference and proposed alternative with reason stated for exception.

1.07 QUALITY ASSURANCE

A. Qualification Requirements:

1. The UV equipment SUPPLIER shall demonstrate that the dose required in the performance specification can be met with the amount of equipment proposed.

The UV equipment SUPPLIER shall base sizing of UV system on a Third-Party Reactor Validation Testing calculation to meet the minimum UV design dose as specified herein. The UV equipment SUPPLIER's data and results shall be reviewed by the Engineer. The Engineer can apply the required correction factor to the SUPPLIER's bioassay results. The Engineer's review and opinion of the test protocol, pilot data, and pilot report conclusions shall be deemed final and shall be just cause for the rejection of the proposed equipment. In addition, bioassay calculations shall use one method for the calculation of gpm per lamp for all data, as defined herein as the "Normalized Lamp Velocity."

2. A statement by the UV equipment SUPPLIER listing any deviations or exceptions taken to these specifications shall be provided to the Engineer for the Engineer's review, opinion, and acceptance. The Engineer's final decision regarding the acceptance or denial of any deviations or exceptions shall be just cause for the rejection of the proposed equipment and require that the equipment SUPPLIER supply the disinfection equipment as specified herein.
3. Provide equipment labeled and listed by Underwriters Laboratory (UL) or another nationally recognized testing laboratory, furnished by a single SUPPLIER qualified and experienced in the production of similar equipment.

1.08 DELIVERY, STORAGE AND HANDLING

- A. If required by the Contractor's schedule, the SUPPLIER shall provide equipment in multiple separate freight shipments.
- B. Provide notification in writing to the City and Contractor of approximate delivery date(s) 6 weeks before delivery. Notify same of actual delivery date at least 7 days before delivery. Provide description and approximate weight of shipping container and required equipment for unloading. SUPPLIER shall coordinate delivery, unloading, and storage with Contractor.
- C. Moisture sensitive products shall be stored in weather tight enclosures. Weather tight enclosures must be a cargo container suitable for transport either by train or cargo ship. SUPPLIER will designate those items that need to be store in a moisture controlled environment. Crates covered in tarps are not acceptable. All damaged materials related to storage shall be replaced with new materials.
- D. SUPPLIER shall coordinate the delivery of equipment with Contractor. SUPPLIER shall revise schedule for delivering equipment packages if requested by Contractor without additional cost to Contractor.
- E. Storage:
 1. General: Contractor shall store, and handle in accordance with the SUPPLIER's printed instructions.
 2. Packing and Shipping: SUPPLIER shall deliver equipment to the project site in the original containers with seals unbroken and labeled with SUPPLIER's identification and number.
 3. Delivery: SUPPLIER shall deliver materials dry and undamaged to the Contractor. During the delivery process materials must be stored out of contact with the ground.
 4. Unpacking: The City shall review the shipping containers and advise the Contractor which containers can be destroyed.

1.09 PROJECT CONDITIONS

- A. Site Environmental Conditions:
 - 1. Refer to Section 01610.

1.10 SUPPLIER'S WARRANTY

- A. The equipment SUPPLIER shall warrant the City against defects in materials and workmanship in accordance with the INSTRUCTIONS TO PROPOSERS and the following:
 - 1. General Warranty:
 - a. The equipment furnished under this section shall be free of defects in materials and workmanship, including damages that may be incurred during shipping, storage, and installation, for a period of 2 years which shall commence after successful completion of the Initial Performance Test (Substantial Completion of the UV system).
 - b. All wiring in the channel exposed to UV light shall be warranted for 15 years by the SUPPLIER. If the wiring fails before 15 years have elapsed, the SUPPLIER shall be responsible for the replacement of the wires and the labor.
 - c. SUPPLIER shall guarantee that for components manufactured by the SUPPLIER, replacement parts shall continue to be available to the City for a minimum of 20 years from date of successful completion of Initial Performance Test. SUPPLIER shall guarantee that, if SUPPLIER or SUPPLIER's product line is sold, SUPPLIER shall make provisions such that all guarantees, warranties, and bonds will remain in effect and that replacement parts and operational support shall continue to be available to the City for the time period specified above.
 - d. No warranties shall be pro-rated, and all warranties shall include all costs associated with required site visits, inspections, equipment removal costs, and equipment installation costs.
 - e. All warranties and support shall be provided directly by the SUPPLIER and not the local manufacturer's representative.
 - 2. UV Lamp Warranty:
 - a. The UV lamps shall be warranted by the SUPPLIER against lamp failure as specified herein. Lamp failure occurs when the ratio of the available UV light output of the lamp to the UV light output of a new lamp after 100 hours of burn-in is less than the lamp age factor. The SUPPLIER shall provide a warranty for the performance of the UV lamp for a minimum period of operating hours per lamp as stated in Form 1, which shall commence after successful completion of the Initial Performance Test (Substantial Completion).
 - b. The SUPPLIER shall replace any lamp that fails before the end of the operating hours per lamp as stated in Form 1 at no cost to the City, with freight and insurance paid by SUPPLIER. Installation of the failed lamp can be performed by the City.
 - c. This guarantee shall be limited by the guaranteed number of start/stop cycles. The guaranteed lamp start/stop cycle shall be 4 stop/start cycles per 24-hour period over the life of the lamp. The automation associated with the UV equipment shall be programmed to prevent more than 4 start/stop cycles per day. Additionally, the automation system must log the operational hours for each individual lamp.

- d. The guaranteed lamp life shall not be limited by time periods when the plant is not in operation and/or when the UV system is shut down.
 - e. SUPPLIER shall ensure all returned UV lamps (old/new) are recycled upon receipt of the returned lamps at the manufacturing headquarters for the life of the UV Disinfection System (20 years after successful completion of the Initial Performance Test).
3. UV Ballast Warranty:
 - a. SUPPLIER shall guarantee all ballasts against failure for a minimum period of 5 years, which shall commence after successful completion of the Initial Performance Test (Substantial Completion of the UV system).
 - b. SUPPLIER shall replace any ballast that fails before the end of the designated warranty period at no cost to the City, with freight and insurance paid by SUPPLIER. Installation of the failed ballast can be performed by City.
 4. UV Quartz Sleeves Warranty:
 - a. SUPPLIER shall guarantee all quartz sleeves against failure for a minimum period of 5 years, which shall commence after successful completion of the Initial Performance Test (Substantial Completion of the UV system). Sleeve failure is defined as permanent loss of 10 percent sleeve transmittance relative to new sleeve transmittance.
 - b. SUPPLIER shall replace any quartz sleeve that fails before the end of the designated warranty period at no cost to the City, with freight and insurance paid by SUPPLIER. Installation of the failed quartz sleeve can be performed by City.
 5. UV Sensor Extended Warranty:
 - a. SUPPLIER shall guarantee all UV sensors against failure for a minimum period of 3 years, which shall commence after successful completion of the Initial Performance Test (Substantial Completion of the UV system). Sensor is deemed to have failed when the sensor no longer measures UV intensity or sensor does not meet the specified accuracy of less than 20 percent. Ad1
 - b. SUPPLIER shall replace any UV sensor that fails before the end of the warranty period at no cost to the City, with freight and insurance paid by SUPPLIER. Installation of the failed UV sensor can be performed by City.
 6. Performance Warranty:
 - a. The equipment furnished under this section, when operated within the conditions specified in the Contract Documents, will meet or exceed the performance requirements specified herein for a period of 3 years which shall commence after successful completion of the Initial Performance Test (Substantial Completion of the UV system).
 - b. If the UV equipment fails to meet design and performance criteria, the UV equipment SUPPLIER shall modify, change, or add equipment as necessary to meet performance criteria. SUPPLIER shall be responsible for any additional costs to Contractor or City due to changes (including but not limited to piping, mechanical, structural, or electrical changes) or additional equipment as necessary to meet performance requirements. This includes design, engineering, construction, as well as equipment.
 - c. The City shall make available the UV Disinfection System electronic data records of historical performance for SUPPLIER's review. The automation system shall log all relevant performance data and store it in the historical database.

- d. If the system fails to meet specified performance criteria during the Initial Performance Test, or the warranty period following the date of successful completion of the Initial Performance Test, and the SUPPLIER is unable to modify the system through the addition of UV banks or other elements, then the SUPPLIER shall be responsible for complete removal of nonconforming system and subsequent installation of UV disinfection products that are capable of meeting specified performance conditions.
- B. The equipment SUPPLIER shall warrant the City regarding power consumption as follows:
1. The SUPPLIER shall furnish a warranty stating that the installed UV system shall not exceed the maximum power consumption as specified in Form 1.
 2. If this maximum power usage is exceeded due to system modifications or by design, the SUPPLIER agrees to pay City the cost of upgrading any portion of the electrical system to accommodate the new maximum power consumption. This includes material, labor and engineering costs.
- C. End of Warranty Inspection:
1. Inspection:
 - a. SUPPLIER's representative shall perform a minimum of two day (sixteen hour) inspection of SUPPLIER's UV equipment, within 30 days prior to the 2-year anniversary date of the equipment warranty.
 - b. SUPPLIER shall ascertain or appraise the following:
 - a) Status of equipment and installation after normal usage.
 - b) Adherence to SUPPLIER's recommended maintenance and operation of equipment.
 - c) Quality of sleeve cleaning and recommended sleeve cleaning interval.
 - d) All electrical connections.
 - e) Calibration of duty UV sensors using reference UV sensors.
 - f) Operation of alarms.
 - g) UV transmittance monitors.
 - c. SUPPLIER shall make adjustments as necessary to restore equipment within original tolerances.
 - d. SUPPLIER shall submit a written letter report to the City covering the inspection items and including recommendations where applicable.

1.11 MAINTENANCE

- A. Special Tools:
1. Provide 1 set of all special tools required for operation and maintenance, and complete assembly or disassembly of the UV disinfection system.
 2. Lamp Testers: Two (2) Greenlee LT100 Lamp Testers.
- B. Spare Parts: The UV Disinfection System SUPPLIER shall furnish, at a minimum, the following spare parts and safety equipment for each system provided:
1. UV Lamps: Ten (10) percent additional.
 2. UV Ballasts (complete): Five (5) percent additional.
 3. Quartz Sleeves: Ten (10) percent additional.
 4. Lamp Sealing Rings or Holder Seals: Ten (10) percent additional.
 5. Lamp Plugs: Five (5) percent additional.
 6. Wiper or Wiper Rings (if applicable): Ten (10) percent additional.

7. UV Sensors: Ten (10) percent additional.
8. Proprietary Printed circuit boards: Five (5) percent additional of each type supplied with a minimum quantity of one (1).
9. Cleaning Solution (if applicable): One (1) full charge for 1 year after acceptance of Initial Performance Test.
10. Pump or Electric Motor with Gearbox used to drive cleaning system and/or UV module lift system: One (1) of each type used, if required for System.
11. Fans: Five (5) percent additional of each type supplied with a minimum quantity of one (1) of each type.
12. Fuses: Five (5) of each type of fuse used in the UV system.
13. Benchtop UV Transmittance Meter: One (1), manufactured by Real Tech Inc. (Model # UV254 P200).

1.12 WORK BY OTHERS

- A. The following items are provided by Contractor but shall be coordinated by the SUPPLIER during the Design Assistance provided by SUPPLIER to Engineer. These items will include:
 1. Structural:
 - a. Concrete channels for the UV reactors.
 - b. Foundation/housekeeping pads and additional housing for supplied UV disinfection equipment.
 - c. Protective coatings for concrete.
 - d. Anchor bolts will be provided and installed by Contractor; anchor bolt design by UV SUPPLIER.
 2. Mechanical:
 - a. Inlet and outlet gates used to isolate the channel from service shall be supplied and installed by the Contractor.
 - b. Magnetic flow meters used to measure the flow in each channel shall be supplied and installed by the Contractor.
 - c. Installation materials for instrumentation and automatic valves including but not limited to air/sample line tubing, fittings, and mountings.
 3. Electrical:
 - a. Electrical wiring interconnections (including wiring, conduits, transformers, distribution panels, breakers and other appurtenances required to provide power connections as needed) from the electrical power source to the UV disinfection equipment and system control panels. Contractor shall also be responsible for determining the correct wire sizing and coordinate this information with the UV SUPPLIER.
 - b. Ethernet communications connection to the City's Plant Control System.
 4. Other:
 - a. Receiving, unloading, and safe storage of equipment at site or a storage facility until ready for installation.
 - b. Raw materials and utilities during equipment testing.
 - c. Laboratory services, operating and maintenance personnel during equipment checkout, startup and operations.
 - d. Any onsite painting or touch-up painting of equipment supplied.

PART 2 PRODUCTS

2.01 SUPPLIERS

- A. The UV Disinfection System shall be manufactured by one of the following equipment manufacturers:
 - 1. Calgon Carbon C³500D.

2.02 GENERAL PRODUCT REQUIREMENTS

- A. Description of Work:
 - 1. The work under this section shall cover furnishing a complete and operational open-channel, gravity-flow, UV disinfection system. The system shall be complete with UV banks, power distribution, system control, level control weirs, UV detection system, and automatic cleaning system as shown on the Drawings and specified herein.
 - 2. The system shall utilize active control based on the Third-Party Reactor Validation Testing and using the following parameters:
 - a. UV intensity, as measured by a calibrated sensor technology meeting USEPA UVDGM standards.
 - b. Water quality (UVT).
 - c. Water flow.
 - d. Power (Ballast Power Level or Percent Lamp Current).
 - e. Based on these parameters, the system will automatically vary the UV lamp power proportionally to continuously meet the dose requirement.
 - 3. The dose delivered by the UV system shall be linearly variable within a minimum range of 60 to 100 percent of maximum power in both manual and automatic operating modes. If the variability differs between modes, the automatic mode of operation shall be the sole mode considered.
 - 4. The system shall be capable of continuous disinfection while automatically cleaning the UV lamp sleeves without reducing or shadowing the output of the lamps. For systems that require batch chemical cleaning, system redundancy can be used during the batch cleaning process to maintain the required dose.
 - 5. The UV sensor technology employed by the SUPPLIER must continuously track the combined intensity loss due to lamp aging and sleeve fouling and alarm when the intensity level drops to a set percentage of the intensity level of the system at full power with new lamps and clean sleeves. The target percentage is defined as the product of the lamp age factor and fouling factor (attenuated lamp condition) at the lamp's minimum power setting.
- B. General:
 - 1. Unless otherwise specified, all components in contact with the effluent and/or UV light shall be Type 316 stainless steel, Type 214 quartz glass, Viton or Teflon.
 - 2. All fasteners in contact with the effluent shall be Type 316 stainless steel.
 - 3. Unless otherwise specified, all metal components above the effluent shall be Type 304 stainless steel.
 - 4. All enclosures located outdoors shall be Stainless Steel - NEMA 4X (IP 66) and all located indoors shall be Mild Painted Steel -NEMA 12 (IP 52), unless specified otherwise.

5. All stainless steel components, enclosure panels, and welds in stainless steel subassemblies shall be cleaned, pickled and passivated to protect the stainless steel:
 - a. Following shop fabrication of stainless steel members, clean and passivate fabrications.
 - b. Finish requirements: Remove free iron, heat tint oxides, weld scale and other impurities, and obtain a passive finished surface.
 - c. Provide quality control testing to verify effectiveness of cleaning agents and procedures and to confirm that finished surfaces are clean and passivated:
 - 1) Conduct sample runs using test specimens with proposed cleaning agents and procedures as required to avoid adverse effects on surface finishes and base materials.
 - d. Pre-clean, chemically descale (pickle), and final clean fabrications in accordance with the requirements of ASTM A 380 to remove deposited contaminants before shipping:
 - 1) Passivation by citric acid treatment is not allowed:
 - a) If degreasing is required before cleaning to remove scale or iron oxide, cleaning (pickling) treatments with citric acid are permissible; however, these treatments shall be followed by inorganic cleaners such as nitric-hydrofluoric acid.
 - 2) Provide acid descaling (pickling) in accordance with Table A1.1 of Annex A1 of ASTM A 380.
 - 3) After pickling, final cleaning of stainless steel shall conform to Part II of Table A2.1 of Annex A2 of ASTM A 380.
 - e. After cleaning, inspect using methods specified for "gross inspection" in ASTM A 380.
 - f. Improperly or poorly cleaned and passivated materials shall not be shipped and will not be accepted at the job site.
6. All wiring exposed to UV light shall be Teflon-coated.
7. System shall include automatic cleaning system, system control panel(s), and accessories as specified.

2.03 DESIGN SUPPORT SERVICES

- A. The SUPPLIER shall provide design support services to the CITY and ENGINEER in order to fully integrate the selected UV disinfection system into the final contract documents for use by the CONTRACTOR.
- B. Scope of the services shall include but not limited to the following tasks:
 1. The SUPPLIER's team shall attend an initial three-day design and controls workshop to be conducted in the ENGINEER's office in Walnut Creek, CA.
 2. SUPPLIER team shall include the project manager, process specialist and controls engineer.
 3. SUPPLIER shall submit Technical Submittals as required to adequately define the UV disinfection system. The initial workshop shall be scheduled after the Technical Submittals have been submitted and reviewed by the CITY and ENGINEER.
 4. During this workshop, the following topics will be discussed:
 - a. Review and validate hydraulics, flow distribution between UV channels, and flow and level control measures.

- b. Review and validate Process and Instrumentation Diagrams (P&IDs) and electrical design relative to the UV System requirements.
 - c. Review and validate baffle plate selection, design criteria, and layout and provide approval.
 - d. Review and validate the whole UV disinfection process layout, design criteria, and provide approval.
 - e. Review and validate the UV disinfection equipment maintenance, removal, accessibility, and crane layout during the design.
 - f. Review and validate the UV support equipment and layout, including chemical systems, electrical equipment as well as process control equipment and ancillaries.
 - g. Review, validate and coordinate the operations and controls of the UV disinfection system.
 - h. Review and validate specifications for installation and testing of the UV System by CONTRACTOR.
5. For each design submittal, SUPPLIER shall provide up to 40 hours of time to review and provide comments on construction documents prepared by the ENGINEER during the design, at 60 and 90 percent design completion levels. (a total of 80 hours).
 6. Respond to ENGINEER's questions during the design.
 7. The SUPPLIER's team shall attend a final one-day design and controls workshop to be conducted in the ENGINEER's office in Walnut Creek, CA, prior to bidding for final coordination.
 8. The SUPPLIER shall provide an additional 80 hours of PLC and HMI programming to incorporate control, interface and display requirements not specifically requested in the specifications but agreed upon during the workshops.

2.03 DESIGN, CONSTRUCTION, AND MATERIALS – CALGON CARBON C³500D SYSTEM (As modified during February 2017 submittal review)

- A. System Manufacture and Construction:
 1. The UV disinfection system shall be manufactured by Calgon Carbon Corporation.
 2. System shall include automatic mechanical cleaning, master system control panel, power distribution center for each bank and accessories as specified.
- B. Lamp Array Configuration:
 1. The lamp array configuration shall be the uniform array with all lamps parallel to each other and to the flow. The lamps shall be evenly spaced in horizontal and vertical rows with centerline spacing equal in both directions.
 2. The single array pattern shall be continuous and symmetrical throughout the reactor.
 3. The system shall be designed for complete immersion of the UV lamps including both electrodes and the full length of the lamp tube in the effluent. Both lamp electrodes shall operate at the same temperature and be cooled by the effluent.
- C. UV Lamps:
 1. The lamps contained in the UV system must be the same LPHO amalgam lamps that were tested during system validation testing.

2. Electrical connections at one (1) end.
3. Each connection shall have a four (4) pin ceramic connector.
4. The lamp design shall be a LPHO amalgam lamps of the pre-heat start design.
5. The filament of the lamp shall be clamped design, significantly rugged to withstand shock and vibration.
6. Minimum UV lamp arc length shall be 57 inches.
7. Lamps shall not produce any ozone.
8. The lamp bases shall be of a durable construction resistant to UV and ozone.
9. The lamp design shall prevent electrical arcing between electrical connections in moist conditions.

D. Lamp End Seal and Lamp Holder:

1. The open end of the quartz sleeve shall be sealed by means of a Type 316 stainless steel nut which threads onto a coupling and compresses a sleeve O-ring.
2. The sleeve coupling nut shall have a knurled surface to allow a positive hand grip for tightening. The nut shall not require any tools for removal.
3. The quartz sleeve shall be held in place by means of an O-ring and compression washer.
4. The UV lamp rack shall be designed to isolate the individual lamps and to prevent moisture from coming in contact with the electrical connections of other lamps in the event of a seal failure or a quartz sleeve fracture.

E. Quartz Sleeves:

1. Type 214 clear fused quartz circular tubing as manufactured by General Electric or equal.
2. The sleeve wall thickness shall be at least 1.50 mm (nominal).
3. The quartz sleeve material shall be rated for 90 percent UV transmission and shall not be subject to solarization over its lifespan.
4. The quartz sleeves shall be fabricated with one end closed so that only the open end requires sealing.

F. UV Module (UVM):

1. Each UVM will consist of eight (8) lamps with the electronic ballasts powering these lamps mounted in the Power Distribution Center (PDC) located adjacent to the UV lamp bank. The UV module frame is fabricated from Type 316/304 stainless steel. All components in contact with the effluent are Type 316 stainless steel.
2. Each lamp shall be enclosed in its individual quartz sleeve.
3. The UVM shall be connected to receptacles on the Power Distribution Center (PDC) by means of two multi-conductor cables with modular repairable connectors. The cable connector and all of its components shall be field repairable. The connector shall be of a "Snap-On" design having no threads that may bind or be subject to cross threading. The connector shall also allow for visual confirmation that the connection is locked in place. Pins shall be made from a copper alloy with gold plating. The connector shall be coated with a corrosion resistant finish and all levers, bolts and screws shall be made of stainless steel. The connector shall meet IP 65 (UL574) requirements for direct water spray when mated.
4. At the point of exit from the UVM, the multi-conductor cable shall pass through a water resistant strain relief.

5. The UVM shall be designed so that when they are in place, in the UV banks with the grating removed, they shall support a live load of 300 lbs. without damage. The tops of the racks shall present a surface on which workers can stand to access the racks in the UV bank.
6. The UVM shall incorporate a protective shield to prevent UV light from radiating above the lamp bank during normal operation.
7. The UVM shall be designed to comply with NEMA 6P (IP 67) ratings.

G. UV Bank Support Rack:

1. Quantity: One per UV bank.
2. Design: Type 316 stainless steel, freestanding frame used to support one full UV bank in the channel or on the deck outside the channel. UV Banks and any required accessories shall be designed such that the entire bank can be lifted from the channel as single unit.
3. If the rack is part of the UV module support structure in the channel, it shall be designed such that the entire UV bank and rack can be lifted out of the channel as a single unit and placed on the deck area outside of the channel. A permanent guiding structure shall be installed in the channel to allow the UV bank and support rack to be easily set into the correct position when placed back in the channel. The guiding structure shall be precisely adjusted during installation. Once correctly in position the guiding structure shall be permanently fixed during installation to prevent any movement during the life of the UV Disinfection System. The removable rack shall not impact dose delivery or alter the lamp spacing that was tested during the Third-Party Reactor Validation Testing.

H. Automatic Cleaning System:

1. Each UV bank shall be equipped with an automatic mechanical cleaning system. The cleaning system shall maintain uniform wiping tension and cleaning over complete wiping length of the quartz sleeve and the UV sensors.
2. The proposed cleaning system utilizes stainless steel scrapers to keep the quartz sleeves clean. The stainless steel wire is wound like a spring and is assembled with Teflon spacers and stand-offs to form a scraper assembly. The quartz sleeve must be removed from the lamp rack to replace the scraper assembly.
3. When the cleaning system is not in use, the drive arm will be stationary and parked in the home position, UV module connector end.
4. The scrapers will be electrically actuated by an AC motor housed at the top of the UV module. Each UV module has its own cleaning motor.
5. The cleaning system shall have the capability of being operated in either manual or automatic mode. In automatic mode, the cleaning wipers shall be initiated and controlled by the operator interface.
6. Cleaning cycle intervals be field adjustable within the range of once per hour to once per week.

I. UV Intensity Detection System:

1. Each UV bank shall have a minimum of one UV intensity sensor.
2. The UV intensity sensor shall be submersible.
3. The UV intensity sensor shall not degrade after prolonged exposure to UV light.

4. The UV intensity sensor shall continuously measure only the germicidal portion of the light generated (253.7 nm plus or minus 20 nm). The sensor must have a minimum sensitivity of 90 percent of the germicidal light.
5. The UV intensity sensor shall be accurate within 5 percent.
6. The UV intensity shall be displayed at the HMI when prompted, and displayed in milliwatts per square centimeter.
7. The UV intensity sensor shall be factory calibrated to a national testing standard.
8. Sensor should be contained in its own quartz sleeve.

J. Electrical:

1. General:
 - a. Each UV bank shall be powered from the Power Distribution Center.
 - b. Each ballast shall drive 1 low-pressure, high-output lamp.
 - c. Power factor shall not be less than 98 percent.
 - d. SUPPLIER to supply all cabling between the lamps and ballasts. SUPPLIER shall provide all power interconnect and data cables and plugs between the UV modules and the Power Distribution Center.
 - e. UV SUPPLIER to perform all terminations between lamps and ballasts.
 - f. Electrical supply for the water level switch(es) will be provided by the System Control Center or the Power Distribution Center.
 - g. All enclosures located outdoors shall be NEMA 4X Stainless Steel Type 304 unless otherwise specified. All panels shall be self-supporting.
 - h. Harmonic distortion shall be measured with all new UV banks in all channels at 100 percent rated load in accordance with a general system classification meeting the recommended maximum harmonic distortion levels in IEEE 519-2014 Tables 1, and 2 at the PCC. If these levels cannot be achieved at the installed site, the SUPPLIER shall furnish and install all necessary active filters as manufactured by TCI or Schneider Electric series AccuSine filters to comply with IEEE 519-2014 at no additional cost to the City.

K. Power Distribution Center (PDC):

1. The electrical supply to each PDC shall be 480/277VAC, 3 Phase, 4 Wire (plus ground) connection.
2. Each PDC shall house all control gear, and electronic ballasts associated with one UV bank.
3. PDC enclosure material will be made of Stainless Steel Type 304 - NEMA 4X (IP 66).
4. All Power Distribution Centers to be UL approved or equivalent.
5. Data concentration shall be through integrated circuit boards located inside the PDC.
6. Fusing and ground detection circuits shall be located inside the PDC.
7. All PDC's shall be self-supporting.
8. Each UV module shall be protected by a panel mounted thermal magnetic circuit breaker device. Circuit breakers shall be mounted in the PDC. Each circuit breaker shall provide visual trip indication and be capable of regular testing. To ensure safe operation, provide with ground fault circuit interrupter.
9. The PDC shall provide power to the UV lamp modules via plug-in multi-pin connectors. This facilitates module removal from the UV channel for inspection and cleaning when required.

10. Each PDC shall include its own main breaker interlocked with the PDC door. The main breaker shall have a minimum interrupting capacity of 65 kA. This will allow maintenance personnel to perform any service work per local safety regulations.
11. The PDC shall be equipped with the necessary components to allow each bank of lamps to be controlled in either the Remote (Automatic) or Local (Manual) mode. Each PDC shall have a Control Card and Operator Station used to control and monitor the bank of lamps.
12. Each PDC shall operate as an independent unit. In UV systems that include multiple banks, the operation of each PDC shall not be affected by the operation of other PDC's.

L. System Control Center (SCC):

1. The UV control system shall include one Master UV PLC and associated enclosure for control and monitoring of the entire UV system. The master UV PLC shall be located in the UV building, as indicated on the Drawings. The Master UV PLC shall be provided and programmed as specified in Section 17055, the Drawings, and this Section.
2. The UV control system shall include six Channel Control Centers (CCC), one for each channel. The CCC will house the necessary PLC equipment to communicate with the five PDCs and all of the required inputs and outputs for each channel. The CCC will be mounted outdoors and shall be made of Stainless Steel Type 304 - NEMA 4X (IP 66).
3. Electrical supply to the SCC will be 120 volts, 1 phase. Furnish an uninterruptible power supply (UPS) installed inside the PLC enclosure as required. UPS shall conform to the requirements in Section 17055. Where SUPPLIER's equipment requires other voltages, SUPPLIER shall provide any transformers necessary for proper system operation.
4. UV System control and monitoring shall be provided through display touchscreen to allow complete operator interface. Hardwired panel devices and meters shall not be permitted.
5. The Master UV PLC control panel shall be provided with Human Machine Interface (HMI) as specified in Section 17055. Operator interface shall be menu-driven with automatic fault message windows appearing upon alarm conditions.
6. Bank status shall be capable of being placed either in Manual (ON/OFF) or Auto mode.
7. Banks shall be cycled in a lead/lag rotation through automatic control at the Master UV PLC for equal wear, and timed off to minimize bank cycling.
8. Elapsed time of each bank shall be recorded and displayed at the HMI when prompted.
9. Master UV PLC Panel shall be UL approved, rated NEMA 12. Panel shall be free standing.
10. Provide heating and cooling for the panel to meet the heating and cooling requirements of Section 17055.
11. The Master UV PLC shall be provided with all networking equipment required to properly receive and communicate information to and from the plant SCADA system.

M. Chemical Cleaning Tank:

1. The UV system supplier shall furnish a 304L stainless steel liner with drain stub and fiber-reinforced plastic (FRP) cover for installation by the Contractor.

- The module cleaning station should accommodate one complete UV bank of UV modules immersed in citric or phosphoric acid (5-10 percent concentration with pH between 2.0 and 3.0).
2. The location and elevation of the chemical cleaning tank located adjacent to the channels, as indicated on the Drawings.
 3. The chemical cleaning tank shall be provided with a drain connection.

2.04 ACCESSORIES

- A. Face Shields:
 1. Quantity: Four (4).
 2. Design: Block UV light wavelengths between 200 and 400 nm.
- B. Water Level Sensors:
 1. A minimum of two point ultrasonic level sensors, provided by SUPPLIER, shall be included for each channel and shall be as specified in Section 17055. Wiring of the level sensor shall ensure that each PDC is independently operated.
 2. During manual, automatic, and remote modes of system operation, the water level sensor shall ensure that the automatic cleaning system is disabled if the water level in the channel drops below an acceptable value.
- C. On-Line UV Transmittance (UVT) Monitor:
 1. Provided by SUPPLIER as specified in Section 17055.
 2. SUPPLIER shall supply all components necessary for mounting the UVT monitor as specified.
- D. Inlet Baffle Plate:
 1. Provide two inlet baffles per channel at upstream end of each UV channel at location as indicated on the Drawings and as designed by the UV equipment SUPPLIER.
 2. Design:
 - a. Designed to promote plug flow to the UV bank.
 - b. Located at upstream end of UV channel.
 - c. Designed to be removable.
 - d. Maximum headloss: 2.0 inches.
 3. Materials:
 - a. Plates: 316 stainless steel.
 - b. Guides: 316 stainless steel.
 - c. Anchor Bolts and Other Fasteners: 316 stainless steel.
- E. UV Module Support Racks (if applicable):
 1. Quantity: Two module racks.
 2. Design: Stainless steel, freestanding rack with integral brakes on all four legs that can be used to hang a UV module.
- F. UV Module Lifting Sling (if applicable):
 1. Quantity: Two.
 2. Design: Supplier's standard equipment and material.
- G. UV Bank Lifting Sling (if applicable):
 1. Quantity: Two.

2. Design: Supplier's standard equipment and material. Lifting sling shall be rated to handle load of entire UV bank including all UV modules and bank frame (if applicable).

2.05 LEVEL CONTROL WEIR

- A. Contractor shall provide the level control weir as shown on the Drawings.
- B. Design:
 1. The effluent level control weir shall be designed to:
 - a. Maintain the minimum water surface elevation as required for each Suppliers' equipment.
 - b. The UV Disinfection System meets the hydraulic constraints specified herein, under all flow conditions.
 - c. Head over the weir shall not be greater than 2.5 inches at the Peak Flow.
 - d. The level control weir shall be located as indicated on the Drawings.
- C. Materials:
 1. Weir: 316 stainless steel.
 2. Supports, Anchor Bolts and Other Fasteners: 316 stainless steel.

2.06 INSTRUMENTATION AND CONTROLS

- A. General:
 1. Network communication between the UV system and the existing Plant SCADA system shall be provided via an Ethernet connection. A separate Ethernet or communication connection shall be used for PLC communications to the Power Distribution Centers, if required.
 2. All instrumentation used in the UV disinfection system control or monitoring shall be individually fused or circuit breaker protected to minimize the effects of any single point of failure.
 3. The SUPPLIER shall design, provide hardware and software, install, and program the control system in accordance with Section 17055.
- B. Control System and Strategy:
 1. Programming – The UV Equipment SUPPLIER shall be responsible for preparing, writing, and testing all ladder logic associated with the UV control system.
 2. Components – UV Equipment SUPPLIER will provide PLC-based system control center with operator interface and interconnects for monitoring the system through the plant control system. The PLC outputs to the plant control system shall be via Ethernet communication. Provide all required hardware/software and programming.
 3. The system's HMI for the Master UV PLC shall provide manual-auto control of entire UV system.
 4. Provide a separate local-off-remote switch on each PDC enclosure. The PDC local-off-remote switch shall override the control of any other remote device.
 5. UV Disinfection System monitoring and control system shall be as defined in this Section and Section 17055.
 6. All electrical and instrumentation/controls shall be in accordance with Related Sections of Divisions 16 and 17 of the Specifications and meet the requirements of the Project P&IDs. Control and Instrumentation including

- documentation and labels shall conform to related Section 17055. Labeling and wire identification labels shall conform to relevant Sections of Division 16.
7. UV System Control Philosophy:
 - a. Final control philosophies are subject to approval by the Engineer and City.
 - b. The Master UV PLC shall control all the channels of the UV disinfection system. Monitored parameters including UV transmittance, flow, and UV intensity shall be used to operate each channel individually to deliver the setpoint dose. UV transmittance shall be monitored at the influent channel of the UV disinfection process. Flow shall be monitored at each channel. UV intensity shall be monitored for each UV bank.
 - c. All control philosophies shall use the dose equation included in the Engineering Report of the proposed UV Disinfection System, to continuously calculate the delivered dose of the system and automatically vary the lamp power and control the system as required to minimize energy use and deliver the target dose at all times. The dose equation and control philosophy shall be as follows:
 - 1) Dose as a function of flow, UVT, and UV intensity sensor value, directly in agreement with Third-Party Reactor Validation Testing results and approved by the Engineer. The control system shall generate an alarm when the delivered UV dose is less than the setpoint UV dose.
 - 2) Operator shall have the capability of increasing the number of duty channels by one via a pushbutton on the UV HMI or SCADA. The Operator shall also be able to remove this additional duty channel from the channel sequence.
 - 3) Operator shall be able to select the number redundant banks available in an online channel. If the number of available redundant banks is reduced below this setpoint then an additional duty channel shall be placed online.
 8. Control Strategy: The UV control system shall be programmed to control the UV system as follows:
 - a. General:
 - 1) The UV control system shall monitor and control all equipment as specified herein to ensure that the target UV dose of the UV process is delivered in each channel for the given flow, UVT, and attenuated lamp conditions.
 - 2) The PLC program shall have the dose equation that is included in the Engineering Report of the proposed UV Disinfection System.
 - 3) The target UV dose shall be an operator adjustable setpoint. The allowable target UV dose shall range from 50 percent of the design dose to 200 percent of the design dose. The design dose 100 mJ/cm².
 - 4) The Master UV PLC shall execute the following for the entire UV system:
 - a) Monitor the flow in the channel and UV intensity at each bank.
 - b) Monitor the level in each UV channel:
 - (1) Bring additional channel on-line, if available, if the water level in a channel exceeds the HIGH LEVEL.
 - c) Calculate the UV dose delivered in each channel as specified in Articles 2.06.B.7.c and 2.06.B.8.a.2).

- d) Control all UV equipment in the channel to deliver the target UV dose in the channel.
 - e) Control the automatic cleaning system.
 - f) Control the inlet gate of each channel.
 - g) Control the outlet gate of each channel.
 - h) Monitor UVT and UV Intensity (UVI).
 - i) Calculate and trend flow through the system.
 - j) Totalize the effluent flow measured in each channel.
 - k) Signal PDC's to start-up and shutdown as required. The Master UV PLC shall alternate the call sequence of the UV channels. The channels shall be sequenced in a "last on, first off" basis. If a channel fails to meet the target dose, the call sequence shall automatically proceed to the next available channel. If no additional channels are available then the system shall alarm.
 - l) When one channel is to be taken off-line in a multi-channel UV system, the Master UV PLC shall first determine whether the total influent flow can be treated in the remaining channels prior to taking a channel off-line.
 - m) The Master UV PLC shall open and close the inlet and outlet gates, and shall startup standby UV banks and channels as required.
 - n) The Master UV PLC shall monitor the operating hours of each UV channel. A separate HMI screen is required to indicate which UV banks have operated more than 12 hours in a day or more than an average of 8 hours per day over a 7 day period. This information will be used by operations to determine which UV channels need to be sampled for compliance.
- 5) Each channel shall be equipped with a magnetic flow meter to measure the flow in the channel. This information shall be sent to Plant SCADA from the Master UV PLC. The Master UV PLC shall use the measured flow to control the UV lamps within each channel to deliver the target dose. An alarm shall be triggered if the flow differential between the online channels exceeds a setpoint value. The default setpoint shall be 5 percent.
- 6) Level sensors provided must detect high and low water levels in the channel. Level sensors are wired to the PDC and/or SCC.
- b. Automatic Control: With all of the devices in at least two channels (inlet gate, UV banks, and outlet gate) set to Auto mode, the operator can place the UV system into "Auto" mode from the Master UV PLC or plant SCADA. This allows the Master UV PLC to control the UV system to deliver the target UV dose:
- 1) General:
 - a) The lead channel shall always be on-line.
 - b) Based on the measured flow through each channel, the Master UV PLC shall select the number of banks to be in service and the required power setting of each operating bank. The Master UV PLC shall be able to select the minimum and maximum flow through a channel in automatic mode. The selection of the service channels must be based upon the utilization of all channels in the service rotation.

- c) The Master UV PLC shall automatically rotate the lead channel based on a timer. The timer shall be operator adjustable and range from 24 to 200 hours. The automatic rotation of the lead channel shall be Enabled or Disabled via a pushbutton on the appropriate HMI screen.
 - d) The Master UV PLC shall monitor the power level (ballast power level or lamp current) of each UV lamp and minimize the total power required to deliver the target dose in the channel.
 - e) The number of ON/OFF cycles for any one UV bank shall not exceed four (4) times per 24 hours, on average.
- 2) Start-Up Procedure of a Channel: When a channel is required to be brought into service, the Master UV PLC will initiate the following Start-up Procedure:
- a) If an additional channel is required, the outlet gate of that channel shall open. Opening shall be done gradually or in phases to limit the inrush of water.
 - b) The Master UV PLC will monitor the Channel (Banks) effluent low level signals. If the low level signal(s) are not in alarm then turn ON all banks of lamps.
The Master UV PLC shall initiate an automatic cleaning cycle on the banks that have been placed on-line.
After the outlet gate is fully open and lamp warm-up mode expires open the inlet gate.
 - c) If an effluent low level alarm exists in any of the Banks in the channel after the outlet gate is fully open, then generate a Major Alarm, "Minimum Level Not Reached During Warm-up."
 - d) If channel that was placed in service is replacing another channel then after the inlet gate is fully open, close the inlet gate of the channel going offline. After the inlet gate is fully closed, close the outlet gate:
 - (1) The Master UV PLC shall initiate an automatic cleaning cycle on the banks that have been placed off-line.
After the outlet gate is fully closed, turn OFF all banks of lamps within the channel that is going off-line.
 - e) If the inlet gate for the channel that is being placed into service fails to open, then a fail status shall be generated at SCADA and the Master UV PLC. "Inlet Gate Position Failed" alarm is a Major alarm, ensure that the other channel is on-line.
 - f) If the outlet gate for the channel that is being placed into service fails to open, then a fail status shall be generated at SCADA and the Master UV PLC. "Outlet Gate Position Failed" alarm is a Major alarm, ensure that the other channel is on-line.
 - g) After the inlet gate is fully open, switch the Dose Pacing PID to Auto. The Master UV PLC shall optimize the percent ballast power level or lamp current to the UV lamps to deliver the target UV dose.
- 3) Shutdown Procedure of a Channel: When a channel is required to be taken out of service, the Master UV PLC shall initiate the following Shut-down Procedure to be executed by the Master UV PLC:
- a) The Master UV PLC shall calculate the new flow that will occur in each available channel when the channel that is being taken

- off-line is completely out of service AND isolated from the influent flow.
- b) If the number of operating channels is sufficient to treat the total flow with one less channel then the Master UV PLC will initiate the channel Shutdown Procedure detailed in items d) and e) below.
 - c) If the number of operating channels is not sufficient to treat the total flow with one less channel then the Master UV PLC will maintain the current number of operating channels and display an informational warning.
 - d) After each remaining channel is delivering the setpoint dose required for the current flow and additional flow, the inlet gate of the channel being taken off-line shall close. After the inlet gate is fully closed the outlet gate shall close:
 - (1) After the Master UV PLC has sent the close command to the outlet gate, the Master UV PLC shall initiate an automatic cleaning cycle on the banks that have been taken off-line.
 - e) Upon verification that the inlet and outlet gates have been closed, the Master UV PLC shall turn the UV lamps off in the channel being taken out of service.
- c. Upon Major (HIGH Priority) Alarm:
- 1) With the system in Auto mode, the Master UV PLC shall initiate the channel Shutdown Procedure specified herein under the following conditions after the next available channel has been placed in service:
 - a) All Major alarms generated by the Channel and their respective Banks will cause the next available channel to be placed in service and the channel with the Major alarm to be placed out of service.
 - b) If the Major alarm is a low level alarm then the respective Bank of lamps will automatically turn off. Any major alarm generated by the Channel is a Channel shutdown alarm. The next available channel is placed in service and the channel with the Major alarm is placed out of service.
 - c) If another channel is not available then the channel with the Major alarm will remain on-line and the Master UV PLC will generate a Major alarm, "Not Enough Banks Available."
 - d) If the other available channels have a Major alarm then the entire UV system, all banks, shall be placed on-line with the power to all the lamps set to 100 percent.
- d. Upon LOW UVT Alarm:
- 1) The UV system shall continue operating.
 - 2) The Master UV PLC shall trigger a Low UVT alarm at Plant SCADA.
 - 3) A Plant operator shall take a direct sample of effluent in the UV channels and shall measure the UVT with a portable UVT analyzer:
 - a) If UVT measured by the UVT analyzer in the channel is verifiable by the portable UVT analyzer, the UV system shall continue operating without modification.
 - b) If the UVT measured by the UVT analyzer is not verifiable by the portable UVT analyzer, the Plant operator shall, at the Master UV PLC, manually input the Default UVT value to be used to

operate the UV system. The operator shall then select to operate the UV system with the Default UVT at the Master UV PLC. The Default value of the manually entered UVT shall be 61 percent.

- e. Upon High Turbidity Alarm:
 - 1) Divert the filter effluent if any of the following conditions occur:
 - a) An average of 2 NTU or greater within a 24 hour period.
 - b) 5 NTU or greater more than 5 percent of the time within a 24 hour period.
 - c) 10 NTU or greater at any time.
 - 2) Sampling rate for average turbidity calculation shall be 15 minutes which represents 96 samples over a 24 hour period.
 - 3) If diversion capacity is no longer available then SCADA will send the UV system a Bypass signal that will force all available UV channels and banks online and at 100 percent output until the Bypass signal is deactivated.
- f. Upon Loss of Flow Signal Alarm:
 - 1) The Master UV PLC shall trigger a Loss of Flow Signal alarm at Plant SCADA and set the channel flow to the design flow rate. This will allow the UV system to respond while the channel is being rotated out of service.
- g. Upon Minor (LOW Priority) Alarm:
 - 1) The Master UV PLC shall continue normal operation, monitoring and controlling the equipment as needed to deliver the target dose.
- h. Power Failure:
 - 1) Power Failure as Indicated by Power Failure Relay PLC Inputs.
- i. Power Failure Recovery:
 - 1) Following a power failure, loss of power at all PDC's, the plant Master UV PLC shall initiate communications with all of the PDC's and restore the last state of operation prior to the power failure.
 - 2) The number of duty channels placed online after a power failure shall be based on an operator adjustable start-up flow.
 - 3) During a power failure only the inlet gates will close. The outlet gates shall remain in the same state as prior to the power failure.
- j. Out-of-Service (Maintenance) Mode:
 - 1) When Channel Out-of-Service mode is initiated at the Master UV PLC, the Master UV PLC shall execute the Shutdown Procedure as described in Article 2.06.B.8.b.3):
 - a) In Auto mode, the lead channel must remain on-line.
 - b) If there are an insufficient number of banks in the remaining channels to treat the total flow then the Shutdown Procedure shall not continue.
 - c) If there are sufficient number of banks in the remaining channels to treat the total flow then the Shutdown Procedure shall continue.
 - 2) When Bank Out-of-Service mode is initiated at the Master UV PLC, the Master UV PLC shall execute the following procedure:
 - a) If the requested bank is a duty bank then generate the message, "Requested Bank is not Available".
 - b) If the requested bank is a redundant bank in the channel and is offline then place that bank in Out-of-Service mode. This will

- allow plant maintenance staff to make minor repairs in the bank without having to rotate the duty channels.
- 3) While in Out-of-Service mode, the UV control system shall disregard all alarms associated with that channel/bank and treat the channel/bank as off-line with respect to monitoring and reporting values.
- k. Water Level:
- 1) During Manual and Automatic modes of system operation, the Master UV PLC shall ensure that the lamps in the channel extinguish automatically if the water level in the channel drops below an acceptable value. The acceptable water level is specific to each UV system and shall be specified by UV Manufacturer.
 - 2) During Manual and Automatic modes of system operation, the Master UV PLC shall ensure that the automatic cleaning system is disabled if the water level in the channel drops below an acceptable value specified by the UV Manufacturer.
- l. With the UV system in Manual mode, the UV system shall be operated through the local Master UV PLC HMI or Plant SCADA:
- 1) The operator shall have the ability to manually adjust the power (lamp current) of the individual UV banks as well as turn banks ON and OFF.
 - 2) The operator shall have the ability to manually open and close the inlet and outlet gates.
 - 3) The Master UV PLC shall continue to monitor the UV lamps and dose in manual mode.
 - 4) The safety devices shall continue to act as permissives in Manual mode to prevent any potential damages to the UV system.
- m. Alarms and Monitoring:
- 1) Provide HMI alarms and monitoring required as specified herein and on the P&IDs, and transmit all monitored information and alarms to the plant SCADA system.
 - 2) All analog alarm values (setpoints) shall be operator adjustable via the UV HMI and via the plant SCADA system.
- n. Monitoring and Controls:
- 1) Bank ON/OFF status for each bank, status, and action.
 - 2) Lamp Status and Alarm for each bank:
 - a) ON.
 - b) OFF.
 - c) WARM-UP.
 - d) FAILED.
 - e) ADJACENT LAMP FAILURE.
 - f) MULTIPLE LAMP FAILURE.
 - 3) UV Intensity (each bank), setpoints and value.
 - 4) Elapsed time per bank.
 - 5) Lamp run time for each lamp with the ability to reset counter, individually or all lamp timers within a bank.
 - 6) Number of starts per lamp.
 - 7) Cumulative number of ON/OFF cycles (each bank).
 - 8) Bank power (lamp current) process variable (PV) and setpoint (each bank).
 - 9) UV transmittance value.
 - 10) Provide the operator the ability to set the UVT value to manual and manually enter the UVT value based on laboratory testing.

- 11) Setpoint UV dose.
- 12) Flow rate (each channel).
- 13) Turbidity.
- o. Major (High Priority) Alarms:
 - 1) Inlet Gate FAIL – Fail to Open/Close.
 - 2) Outlet Gate FAIL - Fail to Open/Close.
 - 3) Module FAIL (circuit breaker/GFI trip).
 - 4) Bank FAIL to energize.
 - 5) LOW-LOW Intensity (intensity probe reading drops below an operator adjustable setpoint accessible at the Master UV PLC or from the SCADA).
 - 6) LOW Dose (delivered RED dose drops below an operator adjustable setpoint accessible at the Master UV PLC or from the SCADA).
 - 7) Channel HIGH Water Level.
 - 8) Channel LOW Water Level.
 - 9) Not Enough Banks Available FAIL.
 - 10) Adjacent Lamp FAIL (2 or more adjacent lamps fail), include location of lamps by bank and position.
 - 11) Multiple (Percent) Lamp FAIL (more than operator adjustable percentage setpoint lamps fail per bank). Default setpoint will be 5 percent.
 - 12) Power Fail. Alarm generated from external dry contact provided from each UV power distribution center.
 - 13) Loss of Flow Signal at SCC.
 - 14) Loss of UV Intensity Signal at PDC.
 - 15) Loss of UV Transmittance Signal at SCC.
 - 16) Communication Fail, Master UV PLC to SCADA.
 - 17) Communication Fail, Master UV PLC to UV PDC's.
 - 18) High Turbidity.
 - 19) Off-Spec Water Discharge.
- p. Minor (Low Priority) Alarms:
 - 1) LOW UV Intensity (intensity probe reading drops below an operator adjustable setpoint accessible at the UV HMI or from the SCADA).
 - 2) LOW UVT (UV transmittance drops below an operator adjustable setpoint accessible at the UV HMI or from the SCADA).
 - 3) Cleaning System Fail.
 - 4) Individual Lamp FAIL (include location of lamp by bank and position).
 - 5) Cabinet High Temperature.
 - 6) High Turbidity alarm is triggered if the average turbidity within a 24 hour period exceeds the operator adjustable setpoint. Setpoint default shall be 1.5 NTU.
- q. Screen Indicators:
 - 1) All inputs, monitoring and alarms listed in this specification must be shown visibly within the HMI screen. Additional items to be displayed on the HMI screen include:
 - a) Inlet Gate Open and Closed Indications.
 - b) Inlet Gate Manual/Automatic Status Indication.
 - c) Outlet Gate Open and Closed Indications.
 - d) Outlet Gate Manual/Automatic Status Indication.
 - e) Channel Flow.
 - f) UV Transmittance.
 - g) Bank ON/OFF Status.

- h) Bank Manual/Automatic Status.
- i) Bank Warming-up/Operating Status.
- j) Bank Elapsed Time.
- k) Individual Lamp Run Time.
- l) Number of starts per Bank.
- m) Dose Indication per Channel.
- n) UV intensity sensor indications (for each bank).
- o) Turbidity.

PART 3 EXECUTION

3.01 INSTALLATION

- A. Installation of the UV equipment shall be by the Contractor in accordance with the Installation Contract Documents, and SUPPLIER's engineering drawings and instructions. SUPPLIER shall supervise the installation of the UV equipment. The Contractor, in accordance with the Installation Contract Documents and the SUPPLIER's engineering drawings and instructions, shall install the equipment provided by the SUPPLIER under the UV Disinfection Equipment System Proposal.

3.02 FIELD EQUIPMENT CHECKS

- A. Equipment Checks: Prior to the Field Testing (as detailed below, including Hydraulic and Alarm Testing, Initial Performance Test, and other testing), the SUPPLIER shall check that all equipment is installed properly and functions as specified herein. The equipment checks shall include, but not be limited to:
 - 1. Proper installation and alignment of UV support structure defined as the concrete channels containing the UV banks and associated mounting brackets.
 - 2. Water tightness of all submerged equipment.
 - 3. Proper placement of UV lamp banks to assure specified water levels relative to the lamps.
 - 4. Electrical wiring and connections.
 - 5. Proper operation of instrumentation, alarms, and operating indicators associated with the UV equipment.
 - 6. Proper placement and operation of lamp driver/ballast and other equipment in the control panels.
 - 7. Adequate ventilation or cooling in the control panels.
 - 8. Proper operation of lamp bank shutoff switches and ground fault circuit interrupters.
- B. Upon completion of equipment checks, the SUPPLIER shall submit to the City written certification that all UV equipment and accessory equipment associated with the UV disinfection system have been properly installed, are in good condition, are functioning properly, and are in accordance with the Installation Contract Documents.

3.03 FACTORY ACCEPTANCE TESTING

- A. Perform factory testing as specified in Section 01756. The City shall participate in witness testing activities. This participation shall serve as a learning experience for operations and maintenance personnel. One factory visit by three (3) City's PERSONNEL/REPRESENTATIVES for total of 15 person days (including travel time, 5 days per person) must be performed to witness the testing activities. SUPPLIER shall reimburse the City for all travel and lodging cost.

3.04 FIELD TESTING

- A. Following the SUPPLIER's calibration of instruments, the SUPPLIER shall perform Component, System, and Operational Tests on the UV Disinfection Equipment System. It is the responsibility of the SUPPLIER and Contractor to jointly coordinate and arrange the times for testing and startup activities; however, the Contractor must confirm that these times are acceptable to the City.
- B. Calibration:
 - 1. Approximately 60 days prior to the Initial Performance Test, the SUPPLIER shall calibrate all instrumentation associated with the performance testing.
 - 2. If retesting is required, the SUPPLIER shall recalibrate instruments associated with the retest if they have not been calibrated within the previous 60 days and submit that information to the Engineer prior to retesting.
- C. Data Collection:
 - 1. Direct readings from the instruments shall be used in the calculations to determine conformance with the guaranteed performance requirements.
 - 2. Readings shall be obtained from digital trends from the UV Disinfection Equipment System PLCs and by manually recording the values directly from the instrument.
 - 3. Record (and round if necessary) to the level of accuracy of the instrument before any calculations.
 - 4. Collect manual instrument readings at 4-hour intervals during the Initial Performance Test and at 1-hour intervals during the Average Power Consumption Test.
 - 5. There shall be no adjustment to readings or calculations due to random or systematic instrumentation error or accuracy limitations.
 - 6. The SUPPLIER shall document all modifications, changes, or additions and amend the operations and maintenance manuals and record drawings to reflect the modifications.
 - 7. All modifications required as a result of Initial Performance Test failure must be completed within 90 days of the start of the original testing period.
- D. Retesting: The SUPPLIER shall be responsible for all retesting. SUPPLIER shall recalibrate all instrumentation associated with the retest in accordance with this Section, if the instrumentation has not been calibrated within the 60 days immediately prior to the retest:
 - 1. Reimburse the City for all City's costs associated with the retesting, including engineering fees and administration costs.

3.05 HYDRAULIC AND ALARM TESTING

- A. After the City accepts the SUPPLIER's written certification of proper installation of the UV Disinfection System as specified herein, the HYDRAULIC AND ALARM TESTING shall be performed to determine whether or not the equipment meets the hydraulic and alarm conditions specified herein. HYDRAULIC AND ALARM TESTING protocol shall be submitted to the Engineer for approval a minimum of 30 days prior to the scheduled UV system startup:
1. HYDRAULIC AND ALARM TESTING will occur over a period of several days and shall be performed by the SUPPLIER with the assistance of the City.
 2. Channel Level Control Tests: Water level in one channel shall be measured and plotted showing flow rate in MGD on the horizontal axis and water level in inches of water on the vertical axis. The level between the downstream bank of lamps and the weir shall be used to verify the performance specified in the Article 2.05.B.1.c. A minimum of five water level measurements shall be taken during this test at approximately 25, 50, 75, 100 and 120 percent of the design peak flow rate per channel. The water level data will be compared to the design level to ensure compliance.
 3. Headloss Tests: Headloss through one channel shall be measured and plotted on a curve showing flow rate in MGD on the horizontal axis and headloss in inches of water on the vertical axis. The level upstream of the first bank of lamps and the level downstream of the last bank of lamps shall be used to verify the estimated channel headloss specified in Form 1 of this Section. A minimum of five headloss measurements shall be taken during this test at approximately 25, 50, 75, 100 and 120 percent of the design peak flow rate per channel.
 4. Alarm testing shall include simulation of flow and water quality change, lamp and bank failures, sensor performance alarms and the proper maintenance of the minimum UV dose over a range of flow and water quality conditions, in accordance with this specification.

3.06 INITIAL PERFORMANCE TEST

- A. Following completion of the ALARM AND HYDRAULIC TESTING and calibration of all instruments, the SUPPLIER and the Contractor shall conduct the INITIAL PERFORMANCE TEST (IPT). The IPT shall be conducted to determine whether or not the equipment meets the Performance Test Requirements specified herein.
- B. The SUPPLIER and the Contractor shall provide the IPT Report within 10 working days of completion of the test period.
- C. To perform the test, the SUPPLIER and the Contractor shall operate the system continuously over a 15-day test period (about 5 days per channel for a five channel system operated two channels at a time), and collect and summarize data to demonstrate that the system meets the following Performance Test Requirements:
1. Net Production Capacity: System meets average daily flow and peak flow rate requirements as defined in this specification.
 2. Minimum Design Dose: System can deliver the minimum design UV dose as defined in this specification.
 3. UV Disinfected Effluent Water Quality: UV Disinfection system produces an effluent in complete compliance with requirements as specified in this specification.

4. Cleaning: The on-line, automatic cleaning system cleans the lamps as thoroughly and frequently as is required for the system to deliver the minimum design dose at all times. The cleaning system maintains the Sleeve Fouling Factor.
 5. Chemical Cleaning: one UV bank shall be chemically cleaned at the end of the IPT period. This cleaning shall restore the UV sleeves to its state of cleanliness at the onset of the IPT test. This shall be quantified by comparing the UV intensity measured at this bank at the onset of the IPT testing and after the chemical cleaning and adjusting for ambient UVT.
 6. No major changes in equipment or apparatus will be permitted during this test period. However, minor adjustments of equipment that would normally be expected during regular operation of the equipment in plant use may be made.
- D. SUPPLIER shall submit a detailed protocol to be followed for the IPT at least 21 days in advance. The protocol shall include the proposed laboratory to analyze the IPT samples. The protocol and laboratory requires written approval by the City before initiating the tests. The protocol shall specifically detail the operational mode of the system, sampling program, method and schedule, equipment and system monitoring data to be collected with each sampling, the daily (manual) log format, and all sampling and analytical procedures. Upon acceptance of the protocol by the City, the SUPPLIER shall commence the performance test. The SUPPLIER shall collect and process influent and effluent samples 2 times per day and test for turbidity, influent, and effluent Total Coliform, and transmittance for the test period.
- E. Successful completion of the IPT shall be defined as continuous operation over the IPT test period without a major failure in the system and demonstration that system meets all performance requirements established herein. Downtime resulting from City's operation will not be counted against the criteria of "continuous days of operation." If an individual train has a production capacity below 75 percent of its design production capacity for more than 24 hours, the IPT will be considered a failure.
- F. If during the IPT, the system fails or shuts down, the IPT shall then be rerun, as described above, and additional testing, labor, materials, equipment, etc., associated with correcting deficiencies in the UV system, including the repeated performance test, shall be borne by the SUPPLIER. Each repetition of the IPT shall be for a continuous period unless failure to meet performance requirements as defined in this specification has been documented and modifications have been accomplished.
- G. During the IPT, the City shall have the option of collecting samples for independent analyses to confirm measurements and analyses conducted by the SUPPLIER and the Contractor. The Engineer and the City shall have the option of witnessing all testing performed by the SUPPLIER and the Contractor. The SUPPLIER shall notify the Engineer a minimum of 2 weeks in advance of testing.
- H. If the UV Disinfection Equipment System fails to successfully complete the IPT, the SUPPLIER shall have the option of repeating the test two more times, with all costs borne by the SUPPLIER.
- I. Consequences to the SUPPLIER for failure to successfully complete the IPT are specified are listed in Article 1.10.A.6.d.

3.07 ELECTRICAL ACCEPTANCE TESTS

- A. Electrical Acceptance Tests: Verification of warranted power consumption shall be documented by electrical acceptance testing performed by the SUPPLIER with the oversight of the Engineer. This acceptance testing is separate and independent from the operational acceptance test described above, but may be conducted concurrently:
1. Electrical acceptance test shall consist of consecutive 8-hour measurement of kW usage and power factor on the UV bank(s) by the SUPPLIER.
Test Protocol: Banks or Modules of the UV system shall be operated with all lamps in operation at 100 percent power. During this acceptance test, the power consumption, power factor and harmonic values at maximum power shall be measured at the PCC and continuously recorded using a power meter/analyzer (provided by the SUPPLIER for the duration of electrical testing).
 2. The meters each shall provide accuracy of ± 0.25 percent, shall operate at frequencies between 47 to 63 Hz, and shall be furnished with a statement from the meter SUPPLIER attesting to its accuracy. The meters shall be connected to the PCC at a location acceptable to the City. In the event that SUPPLIER disputes results of the electrical acceptance testing SUPPLIER shall bear the entire cost of retesting by a third party mutually acceptable to City and SUPPLIER.
 3. If maximum power consumption exceeds the values provided in Form 1 (at the end of this Specification), the SUPPLIER shall make any and all modifications necessary to cause the system to meet the requirements, all without any additional cost to the City and meet the requirements of the Power Consumption Guarantee specified in Article 1.10.B.
 4. If the power factor is less than that as specified herein, the SUPPLIER shall provide any modifications necessary to adjust the power factor to meet the required power factor.
 5. The installed UV equipment shall comply with the maximum harmonic distortion levels in IEEE 519-2014 Tables 1, and 2 as measured at the PCC. If the harmonic values exceed those recommended in the IEEE 519-2014 Standards for a general system classification, the SUPPLIER shall provide all modifications necessary to cause the system to meet the requirements without any additional cost to the City. The short-circuit current (I_{sc}) at the PCC is 50,000 amps at 480 volts.

3.08 TRAINING OF CITY'S PERSONNEL AND SUPPORT SERVICES

- A. General Requirements:
1. Provide operations and maintenance training for items of mechanical, electrical and instrumentation equipment for each WWTP. Utilize SUPPLIER's representatives to conduct training sessions.
 2. Coordinate training sessions to prevent overlapping sessions.
 3. Provide Draft Operation and Maintenance Manual for specific pieces of equipment or systems prior to training session for that piece of equipment or system.
 4. Satisfactorily complete Alarm and Hydraulic Testing before beginning operator training.

5. Following City's acceptance of Certificate of Proper Installation, the SUPPLIER shall perform a comprehensive training of City's personnel at the site or a classroom designated by the Engineer.
6. The training provided by the SUPPLIER's representative shall consist of both classroom and field training.
7. The SUPPLIER shall give the City a minimum of 30 days' notice prior to initiation of training. The SUPPLIER shall provide the City a copy of the printed training material for review when notice is given.
8. The SUPPLIER shall designate and provide one or more persons to be responsible for coordinating and expediting training duties. The person or persons so designated shall be present at all training coordination meetings with the City.
9. The SUPPLIER's coordinator shall coordinate the training periods with City personnel and shall submit a training schedule for each component of the UV Disinfection Equipment System for which training is to be provided. Such training schedule shall be submitted not less than 30 calendar days prior to the time that the associated training is to be provided and shall be based on the current plan of operation.

B. Specific Requirements per UV System:

1. In addition to the time necessary to complete the requirements established elsewhere within these Specifications, the SUPPLIER's representative shall also provide onsite services at times designated by the City, for the minimum person-days listed below, travel time excluded.
2. Installation Supervision and Inspection: Minimum 10 person-days to handle various requests by the City, including during the unloading of UV disinfection equipment system (assume one trip) and for providing installation assistance for the UV Disinfection Equipment System (assume one trip).
3. Start-Up and Field-Testing: Minimum 20 person-days to handle various requests by the City, for assistance during startup activities (assume two trips).
4. Operator Training: Training shall consist of a minimum of total of 56 hours, for multiple classes, of hands-on lectures on the UV Disinfection Equipment System operation and the maintenance requirements, including lamp chemical cleaning and replacement and repair processes for lamps, ballasts, wipers, sleeves and ancillary equipment. Training shall take place before the Initial Performance Test. The field training shall cover all shifts.
5. Maintenance Service – Service Scheduling:
 - a. By City request any time during warranty period as specified on the Warranty Form.
6. SUPPLIER shall return for 2 additional days 1 year after final acceptance to review UV Disinfection System performance, operations, and maintenance.
7. Factory representatives of the SUPPLIER who have complete knowledge of the proper operation and maintenance of the equipment, shall be provided to instruct representatives of City on the proper start-up, operation, and maintenance.

C. The SUPPLIER shall include in proposal a price for the time and expenses listed above.

D. The SUPPLIER's representative shall be a qualified individual who has previously provided onsite services for the installation, testing, and startup of the SUPPLIER's identical system at a minimum of five wastewater treatment plant of similar size.

- E. Telephone: Include the following in lump sum price:
 - 1. Provide telephone support by means of a toll-free phone number for a minimum period of 3 years following installation and startup.
 - 2. Provide a list of three or more names of individuals qualified to support operation, and provide cell phone numbers for these individuals. At least one of the listed individuals shall be available at all times including nights, weekends, and holidays in the event of an emergency.

- F. Service Scheduling:
 - 1. By City, on request any time during warranty period as specified.
 - 2. Factory representatives of the SUPPLIER who have complete knowledge of the proper operation and maintenance of the equipment, shall be provided to instruct City on the proper start-up, operation, and maintenance:

Form 1				
Parameters			Calgon Carbon C³500D	
Design Factors				
End of Lamp Life Factor			0.85	
Fouling Factor			0.90	
Configuration				
Number of Channels			5	
Number of Banks/Channel			5	
Number of Modules/Bank			13	
Number of Lamps/Module			8	
Total Number of Lamps			2600	
Number of UV Sensors			25	
Number of Power Distribution Centers			25	
Number of System Control Centers			6	
Total Power Consumption (kW)			1660.8	
Headloss across UV Banks in Channel (inches)			1.8	
Lamp Type	Low-Pressure/ High-Output	Low-Pressure/ High-Output	Low-Pressure/ High-Output	Low-Pressure/ High-Output
Lamp Input, W/lamp			520	
Guaranteed Lamp Life, hours			16,000	
Ballast Characteristics				
Type of Lamp Driver/Ballast			Electronic	
Guaranteed Ballast Life, years			5	
Method of Control/Pacing			Dose Pacing	
Third Party Reactor Validation Testing Work Summary				
Bioassay Complete? (Yes/No)			Yes	
If Yes, which test organism			MS2/T1	
NWRI 2012 Approval? (Yes/No)			Yes	

END OF SECTION

SECTION 16050

COMMON WORK RESULTS FOR ELECTRICAL

PART 1 GENERAL

1.01 SUMMARY

- A. Section includes:
 - 1. General requirements applicable to all Electrical Work.
 - 2. General requirements for electrical submittals.

- B. Related sections:
 - 1. The Contract Documents are complementary; what is called for by one is as binding as if called for by all.
 - 2. It is the Contractor's responsibility for scheduling and coordinating the Work of subcontractors, vendors, SUPPLIER and other individuals or entities performing or furnishing any of Contractor's Work.
 - 3. The following sections are related to the Work described in this Section. This list of related sections is provided for convenience only and is not intended to excuse or otherwise diminish the duty of the Contractor to see that the completed Work complies accurately with the Contract Documents:
 - a. Section 01330 - Submittal Procedures - Procurement.
 - b. Section 01410 - Regulatory Requirements.
 - c. Section 01450 - Quality Control - Procurement.
 - d. Section 01600 - Product Requirements.
 - e. Section 01610 - Project Design Criteria.
 - f. Section 01612 - Seismic Design Criteria.
 - g. Section 01756 - Commissioning and Process Start-Up.
 - h. Section 01782 - Operation and Maintenance Data

- C. Interfaces to equipment, instruments, and other components:
 - 1. The Drawings, Specifications, and overall design are based on preliminary information furnished by various equipment manufacturers which identify a minimum scope of supply from the manufacturers. This information pertains to, but is not limited to, instruments, control devices, electrical equipment, packaged mechanical systems, and control equipment provided with mechanical systems.
 - 2. Submit all such changes and additions to the Engineer for acceptance.
 - 3. Review the complete set of Drawings and Specifications in order to ensure that all items related to the electrical power and control systems are completely accounted for. Include any such items that appear on the Drawings or in the Specifications from another discipline in the scope of Work:
 - a. If a conflict between Drawings and Specifications is discovered, refer conflict to the Engineer as soon as possible for resolution.
 - 4. Loop drawings:
 - a. Provide all electrical information required in the preparation of loop drawings including, but not limited to:
 - 1) Equipment terminal numbers.

- D. All electrical equipment and systems for the entire Project must comply with the requirements of the Electrical Specifications, whether referenced in the individual Equipment Specifications or not:
1. The requirements of the Electrical Specifications apply to all Electrical Work specified in other sections.
 2. Inform all vendors supplying electrical equipment or systems of the requirements of the Electrical Specifications.
 3. The Owner is not responsible for any additional costs due to the failure of the Contractor to notify all subcontractors and vendors of the Electrical Specifications requirements.
- E. Contract Documents:
1. General:
 - a. The Drawings and Specifications are complementary and are to be used together in order to fully describe the Work.
 2. Specifications:
 - a. The General and Supplementary Conditions of the Contract Documents govern the Work.
 - b. These requirements are in addition to all General Requirements.
 3. Contract Drawings:
 - a. The Electrical Drawings show desired locations, arrangements, and components of the Electrical Work in a diagrammatic manner.
 - b. Locations of equipment, control devices, instruments, boxes, panels, etc. are approximate only; exercise professional judgment in executing the Work to ensure the best possible installation:
 - 1) The equipment locations and dimensions indicated on the Drawings are approximate. Use the shop drawings to determine the proper layout, foundation, and pad requirements, etc. for final installation. Coordinate with all subcontractors to ensure that all electrical equipment is compatible with other equipment and space requirements. Make changes required to accommodate differences in equipment dimensions.

1.02 REFERENCES

- A. Code compliance:
1. As specified in Section 01410.
 2. The publications are referred to in the text by the basic designation only. The latest edition accepted by the Authority Having Jurisdiction of referenced publications in effect at the time of the bid governs.
 3. The standards listed are hereby incorporated into this Section:
 - a. American National Standards Institute (ANSI).
 - b. American Society of Civil Engineers (ASCE):
 - 1) ASCE 7 - Minimum Design Loads for Buildings and Other Structures.
 - c. ASTM International (ASTM).
 - d. Illuminating Engineering Society (IES). Institute of Electrical and Electronics Engineers (IEEE).
 - e. Insulated Cable Engineers Association (ICEA).
 - f. International Code Council (ICC).
 - g. International Code Council Evaluation Service (ICC-ES):
 - 1) AC 156 - Acceptance Criteria for Seismic Certification by Shake Table Testing of Non-Structural Components (ICC-ES AC 156).

- h. International Society of Automation (ISA).
- i. National Electrical Manufacturers Association (NEMA):
 - 1) 250 - Enclosures for Electrical Equipment (1000 V Maximum).
- j. National Fire Protection Association (NFPA):
 - 1) 70 - National Electrical Code (NEC).
- k. National Institute of Standards and Technology (NIST).
- l. Underwriters' Laboratories, Inc. (UL).

1.03 DEFINITIONS

- A. Definitions of terms and other electrical and instrumentation considerations as set forth by:
 - 1. IEEE.
 - 2. NETA.
 - 3. IES.
 - 4. ISA.
 - 5. NEC.
 - 6. NEMA.
 - 7. NFPA.
 - 8. NIST.
- B. Specific definitions:
 - 1. FAT: Factory acceptance test.
 - 2. ICSC: Instrumentation and controls subcontractor.
 - 3. LCP: Local control panel: Operator interface panel that may contain an HMI, pilot type control devices, operator interface devices, control relays, etc. and does not contain a PLC or RIO.
 - 4. PCM: Process control module: An enclosure containing any of the following devices: PLC, RTU, or RIO.
 - 5. PCIS: Process control and instrumentation system.
 - 6. RTU: Remote telemetry unit: A controller typically consisting of a PLC, and a means for remote communications. The remote communications devices typically are radios, modems, etc.
 - 7. Space: That portion of the panelboard or control panel that does not physically contain a device but is capable of accepting a device with no modifications to the equipment, i.e., provide all standoffs, bus, and hardware, as part of the space.
 - 8. Spare: That portion of the panelboard or control panel that physically contains a device with no load connections to be made.
 - 9. VCP: Vendor control panel: Control panels that are furnished with particular equipment by a vendor or SUPPLIER other than the ICSC. These panels may contain PLCs, RIO, OIT, HMI, etc.
 - 10. Unequipped space: That portion of the panelboard or control panel that does not physically contain a device, standoff, bus, hardware, or other equipment.

1.04 SYSTEM DESCRIPTION

- A. General requirements:
 - 1. The Work includes everything necessary for and incidental to executing and completing the Electrical Work indicated on the Drawings and specified in the Specifications and reasonably inferable there from.

- B. New system:
 - 1. REPLACEMENT OF EXISTING UV SYSTEM:
 - a. The following items are provided by the Contractor but shall be coordinated by the SUPPLIER during the Design Assistance provided by the SUPPLIER to the Engineer. These items include but are not limited to:
 - 1) Electrical wiring and interconnections (including wire, conduit and other appurtenances required to power connections as needed) from the electrical power source to the UV disinfection equipment and master control panel.
 - 2) Ethernet communications connection to the Owner's existing plant control system.
- C. Operating facility:
 - 1. The WWTP is an operating facility. Portions of this facility must remain fully functional throughout the entire construction period. In consideration of this requirement, comply with the following guidelines:
 - a. All outages must be of minimal duration and fully coordinated and agreed to by the Owner. Adjust the construction schedule to meet the requirements of the Owner. All changes in schedule and any needs to reschedule are included in the Work.
 - b. As weather and water demand conditions dictate, re-adjust the construction schedule to meet the demands placed upon Owner by its users.
 - c. Coordinate the construction and power renovation, bear all costs, so that all existing facilities can continue operation throughout construction.

1.05 SUBMITTALS

- A. Furnish submittals as specified in Section 01330 and this Section.
- B. General:
 - 1. Instruct all equipment SUPPLIER and vendors of submittals and operation and maintenance manuals of the requirements in this Section.
 - 2. Furnish the submittals required by each section in the Electrical Specifications.
 - 3. Adhere to the wiring numbering scheme specified by City throughout the Project:
 - a. Uniquely number each wire.
 - b. Wire numbers must appear on all Equipment Drawings.
- C. Use equipment and instrument tags, as indicated on the Drawings, for all submittals.
- D. Submittal organization:
 - 1. First page:
 - a. Specification section reference.
 - b. Name and telephone number of individual who reviewed submittal before delivery to Engineer.
 - c. Name and telephone number of individual who is primarily responsible for the development of the submittal.
 - d. Place for SUPPLIER or Vendor's review stamp and comments.

2. Next pages:
 - a. Provide confirmation of specification compliance in a tabular form that individually lists each specification section, paragraph, and subparagraphs and unequivocally states compliance with said requirement or takes exception to the requirement and lists the reason for said exception and offers alternative means for compliance.
 - b. Include a response in writing to each of the Engineer's comments or questions for submittal packages which are re-submitted:
 - 1) In the order that the comments or questions were presented throughout the submittal.
 - 2) Referenced by index section and page number on which the comment appeared.
 - 3) Acceptable responses to Engineer's comments are either:
 - a) Engineer's comment or change is accepted and appropriate changes are made.
 - b) Explain why comment is not accepted or requested change is not made.
 - c) Explain how requirement will be satisfied in lieu of comment or change requested by Engineer.
 - 4) Any re-submittal, which does not contain responses to the Engineer's previous comments shall be returned for Revision and Re-submittal.
 - 5) No further review by the Engineer will be performed until a response for previous comments has been received.
 3. Remaining pages:
 - a. Actual submittal data:
 - 1) Organize submittals in exactly the same order as the items are referenced, listed, and/or organized in the specification section.
 - 2) For submittals that cover multiple devices used in different areas under the same specification section, the submittal for the individual devices must list the area where the device is intended to be used.
- E. Operation and maintenance manuals:
1. As specified in Section 01782.
 2. Furnish the Engineer with a complete set of written operation and maintenance manuals 8 weeks before Functional Acceptance Testing.
- F. Material and equipment schedules:
1. Furnish a complete schedule and/or matrix of all materials, equipment, and apparatus, that are proposed for use:
 - a. Include sizes, names of manufacturers, catalog numbers, and such other information required to identify the items.
- G. Test reports:
1. As specified in Section 01330. Additional requirements for field acceptance test reports are specified in Sections 01756.
- H. Calculations:
1. Where required by specific Electrical Specifications:
 - a. Because these calculations are being provided by a registered professional engineer, they will be reviewed for form, format, and content but will not be reviewed for accuracy and calculation means.

1.06 QUALITY ASSURANCE

- A. Furnish all equipment listed by and bearing the label of UL or of an independent testing laboratory acceptable to the Engineer and the Authority Having Jurisdiction.

1.07 DELIVERY, STORAGE, AND HANDLING

- A. Shipping precautions:
 - 1. After completion of shop assembly and successful factory testing, pack all equipment in protective crates, and enclose in heavy duty polyethylene envelopes or secured sheeting to provide complete protection from damage, dust, and moisture.
 - 2. Place dehumidifiers, when required, inside the polyethylene coverings.
 - 3. Skid-mount the equipment for final transport.
 - 4. Provide lifting rings for moving without removing protective covering.
 - 5. Display boxed weight on shipping tags together with instructions for unloading, transporting, storing, and handling at the job site. Delivery and inspection.
 - 6. Deliver products in undamaged condition, in manufacturer's original container or packaging with identifying labels intact and legible. Include date of manufacture on label.
- B. Special instructions:
 - 1. Securely attach special instructions for proper field handling, storage, and installation to each piece of equipment before packaging and shipment.

1.08 PROJECT OR SITE CONDITIONS

- A. Site conditions:
 - 1. Provide an electrical, instrumentation and control system, including all equipment, raceways, and any other components required for a complete installation that meets the environmental conditions for the Site as specified in the General Requirements and below.
 - 2. Seismic load resistance:
 - a. Provide electrical equipment with construction and anchorage to supporting structures designed to resist site seismic loads as specified in Section 01612.
 - 3. Altitude, temperature and humidity:
 - a. As specified in Section 01610.
 - b. Provide all electrical components and equipment fully rated for continuous operation at this altitude, with no additional derating factors applied.
 - c. Provide additional temperature conditioning equipment to maintain all equipment in non-conditioned spaces subject to these ambient temperatures, with a band of 10 degrees Fahrenheit above the minimum operating temperature and 10 degrees Fahrenheit below maximum operating temperature, as determined by the equipment manufacturer's guidelines: Provide enclosures for electrical, instrumentation and control equipment, for the ULTRAVIOLET DISINFECTION SYSTEM regardless of SUPPLIER or subcontractor furnishing the equipment, that meet the requirements outlined in NEMA Standard 250 for the following types of enclosures:

4. NEMA Type 4X: Made from corrosion resistant materials (fiberglass reinforced plastic, 316 stainless steel or equal) and are intended for indoor or outdoor use, primarily to protect equipment from exposure to windblown dust and rain, splashing or hose directed water, ice formation and freezing, and corrosion. The usage of fiberglass reinforced plastic must receive specific engineering approval.

1.09 SEQUENCING

Not Used.

1.10 SCHEDULING

- A. General:
 1. As specified in Sections 01756.
 2. Testing requirements are specified in Section 01756 and other sections.
 3. Commissioning and Process Start-up requirements as specified in Section 01756.
- B. Pre-submittal conference:
 1. Before producing any submittals, schedule a pre-submittal conference for the purposes of reviewing the entire Project, equipment, control philosophy, schedules, and submittal requirements.
 2. The Contractor, electrical subcontractor, all vendors, and individual equipment manufacturers furnishing major pieces of equipment must attend.
- C. Factory acceptance testing (FAT):
 1. Where FAT is required for equipment covered by these Specifications, notify the Engineer in writing when the equipment is completed and ready for factory inspection and testing:
 - a. Indicate the desired dates for inspection and testing.
 - b. Schedule the FAT after approval of the FAT procedures submittal:
 - 1) Submit a copy of the test procedures including all forms at least 21 days before any scheduled test date.
 - 2) Notify the Engineer of the scheduled tests a minimum of 15 days before the date of the test.

1.11 WARRANTY

- A. Warrant the Electrical Work as specified in Document 11289:
 1. Provide additional warranty as specified in the individual Electrical Specifications.

1.12 SYSTEM START-UP

- A. Replace or modify equipment, software, and materials that do not achieve design requirements after installation in order to attain compliance with the design requirements:
 1. Following replacement or modification, retest the system and perform additional testing to place the complete system in satisfactory operation and obtain compliance acceptance from the Engineer.

1.13 OWNER'S INSTRUCTIONS

Not Used.

1.14 MAINTENANCE

- A. Before Substantial Completion, perform all maintenance activities required by any sections of the Specifications including any calibrations, final adjustments, component replacements or other routine service required before placing equipment or systems in service.
- B. Furnish all spare parts as required by other sections of the Specifications.

PART 2 PRODUCTS

2.01 MANUFACTURERS

- A. Provide similar items of same manufacturer throughout the electrical and instrumentation portion of the Project.
- B. Allowable manufacturers are specified in individual Electrical Specifications.

2.02 EXISTING PRODUCTS

Not Used.

2.03 MATERIALS

- A. Furnish all materials under this Contract that are new, free from defects, and standard products produced by manufacturers regularly engaged in the production of these products and that bear all approvals and labels as required by the Specifications.
- B. Provide materials complying with the applicable industrial standard as specified in Document 11289.
- C. Stainless steel:
 - 1. Where stainless steel is indicated or used for any portion of the Electrical Work, provide a non-magnetic, corrosion-resistant alloy, ANSI Type 316, satin finish.
 - 2. Provide exposed screws of the same alloys.
 - 3. Provide finished material free of any burrs or sharp edges.
 - 4. Use only stainless steel hardware, when chemically compatible, in all areas that are or could be in contact with corrosive chemicals.
 - 5. Use stainless steel hardware, when chemically compatible, in all chemical areas or areas requiring NEMA Type 4X construction.
 - 6. Do not use stainless steel in any area containing chlorine, gas or solution, chlorine products or ferric chloride.

2.04 MANUFACTURED UNITS

Not Used.

2.05 EQUIPMENT

Not Used.

2.06 COMPONENTS

Not Used.

2.07 ACCESSORIES

Not Used.

2.08 MIXES

Not Used.

2.09 FABRICATION

Not Used.

2.10 FINISHES

Not Used.

2.11 SOURCE QUALITY CONTROL

- A. Provide all equipment that is new, free from defects, and standard products produced by manufacturers regularly engaged in the production of these products.

PART 3 EXECUTION

3.01 EXAMINATION

- A. Review the site conditions and examine all shop drawings for the various items of equipment in order to determine exact routing and final terminations for all wiring and cables.

3.02 PREPARATION

Not Used.

3.03 INSTALLATION

- A. Equipment locations shown on Electrical Drawings may change due to variations in equipment size or minor changes made by others during construction:
 - 1. Verify all dimensions indicated on the Drawings:
 - a. Actual field conditions govern all final installed locations, distances, and levels.

2. Review all Contract Documents and approved equipment shop drawings and coordinate Work as necessary to adjust to all conditions that arise due to such changes.
 3. Make minor changes in location of equipment before rough in, as directed by the Owner or Engineer.
 4. Circuits of different service voltage:
 - a. Voltage and service levels:
 - 1) Low voltage: 120 V to 480 V.
 - 2) Instrumentation: Less than 50 VDC.
 - b. Install different service voltage circuits in separate raceways and junction boxes, manholes, hand holes, and pullboxes.
- B. Labeling:
1. Provide all nameplates and labels as specified by City.
- C. Equipment tie-downs:
1. Anchor all instruments, control panels, and equipment by methods that comply with seismic and wind bracing criteria, which apply to the Site.
 2. All control panels, SSCs, VCPs, LCPs, RTUs, PCMs, etc., must be permanently mounted and tied down to structures in accordance with the Project seismic criteria.

3.04 ERECTION, INSTALLATION, APPLICATION, CONSTRUCTION

Not Used.

3.05 REPAIR/RESTORATION

Not Used.

3.06 RE-INSTALLATION

Not Used.

3.07 COMMISSIONING AND PROCESS START-UP

- A. As specified in Section 01756.
- B. For Owner and Engineer witnessed FAT:
1. The Contractor is responsible for the Owner's and Engineer's costs associated with FAT as specified in Section 01756.
- C. Owner training:
1. As specified in Section 01756 and in this Section.

3.08 FIELD QUALITY CONTROL

- A. Inspection:
1. Allow for inspection of electrical system installation as specified in Section 01450.
 2. Provide any assistance necessary to support inspection activities.
 3. Engineer inspections may include, but are not limited to, the following:
 - a. Inspect equipment and materials for physical damage.

- b. Inspect installation for compliance with the Drawings and Specifications.
- c. Inspect installation for obstructions and adequate clearances around equipment.
- d. Inspect equipment installation for proper leveling, alignment, anchorage, and assembly.

B. Field acceptance testing (Functional Testing):

- 1. Notify the Engineer when the Electrical Work is ready for field acceptance testing.
- 2. Perform the field acceptance tests as specified in Section 11289.
- 3. Record results of the required tests along with the date of test:
 - a. Use conduit identification numbers to indicate portion of circuit tested.

3.09 ADJUSTING

Not Used.

3.10 CLEANING

Not Used.

3.11 PROTECTION

- A. Protect all Work from damage or degradation until Substantial Completion.
- B. Maintain all surfaces to be painted in a clean and smooth condition.

3.12 SCHEDULES

Not Used.

END OF SECTION

SECTION 16123

600-VOLT OR LESS WIRES AND CABLES

PART 1 GENERAL

1.01 SUMMARY

- A. Section includes:
 - 1. 600 volt class or less wire and cable.
 - 2. Instrumentation class wire and cable.
- B. Related sections:
 - 1. Section 01330 - Submittal Procedures.
 - 2. Section 01756 - Commissioning and Process Start-up.
 - 3. Section 16050 - Common Work Results for Electrical.

1.02 REFERENCES

- A. As specified in Section 16050.
- B. ASTM International (ASTM):
 - 1. B3 - Standard Specification for Soft or Annealed Copper Wire.
 - 2. B8 - Standard Specification for Concentric-Lay–Stranded Copper Conductors, Hard, Medium-Hard, or Soft.
- C. CSA International (CSA).
- D. Insulated Cable Engineers Association (ICEA):
 - 1. NEMA WC 70/ICEA S-95-658-1999 - Standard for Nonshielded Power Cables Rated 2000 Volts or Less for the Distribution of Electrical Energy.
 - 2. NEMA WC 57/ICEA S-73-532 - Standard for Control, Thermocouple Extension, and Instrumentation Cables.
- E. National Fire Protection Association (NFPA):
 - 1. 70 - National Electrical Code (NEC).
 - 2. 72 - National Fire Alarm and Signaling Code.
 - 3. 101 - Life Safety Code.
- F. Telecommunications Industry Association/Electronics Industry Association (TIA/EIA):
 - 1. 568-C.2 - Balanced Twisted-Pair Telecommunication Cabling and Components Standard.
- G. Underwriter's Laboratories Inc., (UL):
 - 1. 44 - Thermoset-Insulated Wires and Cables.
 - 2. 1424 - Standard for Cables for Power-Limited Fire-Alarm Circuits.
 - 3. 1569 - Standard for Metal-Clad Cables.
 - 4. 2196 - Standard for Tests for Fire Resistive Cables.
 - 5. 2225 - Standard for Cables and Cable-Fittings For Use in Hazardous (Classified) Locations.

1.03 DEFINITIONS

- A. As specified in Section 16050.
- B. Definitions of terms and other electrical considerations as set forth in the:
 - 1. ASTM.
 - 2. ICEA.

1.04 SYSTEM DESCRIPTION

- A. Furnish and install the complete wire and cable system:
 - 1. The UV System Vendor shall provide the cables to the devices specified in Specification Section 11289 - Low Pressure/High-Output Ultraviolet Disinfection Systems.

1.05 SUBMITTALS

- A. Furnish submittals as specified in Sections 01330 and 16050.
- B. Product data:
 - 1. Manufacturer of wire and cable.
 - 2. Insulation:
 - a. Type.
 - b. Voltage class.
 - 3. American wire gauge (AWG) size.
 - 4. Conductor material.
 - 5. Pulling compounds.
- C. Shop drawings:
 - 1. Show splice locations:
 - a. For each proposed splice location provide written justification describing why the splice is necessary.
- D. Test reports:
 - 1. Submit test reports for meg-ohm tests.

1.06 QUALITY ASSURANCE

- A. As specified in Section 16050.
- B. All wires and cables shall be UL listed and labeled.

1.07 DELIVERY, STORAGE, AND HANDLING

- A. As specified in Section 16050.

1.08 PROJECT OR SITE CONDITIONS

Not Used.

1.09 SEQUENCING

Not Used.

1.10 SCHEDULING

Not Used.

1.11 WARRANTY

- A. As specified in Section 16050.

1.12 SYSTEM START-UP

- A. As specified in Section 16050.

1.13 OWNER`S INSTRUCTIONS

Not Used.

1.14 MAINTENANCE

Not Used.

PART 2 PRODUCTS

2.01 MANUFACTURERS

- A. One of the following or equal:
 - 1. 600 volt class wire and cable:
 - a. General Cable.
 - b. Okonite Company.
 - c. Southwire Company.
 - 2. Instrumentation class wire and cable:
 - a. Alpha Wire Company.
 - b. Belden CDT.
 - c. General Cable BICC Brand.
 - d. Okonite Company.
 - e. Rockbestos Surprenant Cable Corporation.
 - 3. Network cables:
 - a. Belden CDT.
 - b. General Cable.
 - c. CommScope.

2.02 EXISTING PRODUCTS

Not Used.

2.03 MATERIALS

- A. Conductors:
 - 1. Copper in accordance with ASTM B3.

2.04 MANUFACTURED UNITS

- A. General:
 - 1. Provide new wires and cables manufactured within 1 year of the date of delivery to the Site.
 - 2. Permanently mark each wire and cable with the following at 24-inch intervals:
 - a. AWG size.
 - b. Voltage rating.
 - c. Insulation type.
 - d. UL symbol.
 - e. Month and year of manufacture.
 - f. Manufacturer's name.
 - 3. Identify and mark wire and cable as specified by City.
 - a. Use integral color insulation for Number 2 AWG and smaller wire.
 - b. Wrap colored tape around cable larger than Number 2 AWG.
- B. 600 volt class wire and cable:
 - 1. Provide AWG or kcmil sizes in accordance with the NEC:
 - a. Use 75 degree Celsius ampacity ratings.
 - b. Ampacity rating after all derating factors, equal to or greater than rating of the overcurrent device.
 - c. Provide Number 12 AWG minimum for power conductors.
 - d. Provide Number 14 AWG minimum for control conductors.
 - 2. Provide Class B stranding in accordance with ASTM B8:
 - a. Provide Class C stranding where extra flexibility is required.
 - 3. Insulation:
 - a. XHHW-2.
 - b. 90 degrees Celsius rating.
- C. Instrumentation class cable:
 - 1. Type TC.
 - 2. Suitable for use in wet locations.
 - 3. Voltage rating: 600 volts.
 - 4. Temperature rating:
 - a. 90 degrees Celsius rating in dry locations.
 - b. 75 degrees Celsius rating in wet locations.
 - 5. Conductors:
 - a. Insulation:
 - 1) Flame-retardant PVC, 15 mils nominal thickness, with nylon jacket 4 mils nominal thickness.
 - b. Number 16 AWG stranded and tinned.
 - c. Color code:
 - 1) Pair: Black and white.
 - 2) Triad: Black, white and red.
 - 3) Multiple pairs or triads:
 - a) Color-coded and numbered.

6. Drain wire:
 - a. 18 AWG.
 - b. Stranded, tinned.
7. Jacket:
 - a. Flame retardant, moisture and sunlight resistant PVC.
 - b. Ripcord laid longitudinally under jacket to facilitate removal.
8. Shielding:
 - a. Individual pair/triad:
 - 1) Minimum 1.35-mil double-faced aluminum foil/polyester tape overlapped to provide 100 percent coverage.
 - b. Multiple pair or triad shielding:
 - 1) Group shield: Minimum 1.35-mil double-faced aluminum foil/polyester tape overlapped to provide 100 percent coverage.
 - 2) Completely isolate group shields from each other.
 - 3) Cable shield: 2.35 mils double-faced aluminum and synthetic polymer backed tape overlapped to provide 100 percent coverage.
 - c. All shielding to be in contact with the drain wire.

D. Network cables:

1. Category 6:
 - a. General:
 - 1) Provide all Cat 6 cables meeting the standards set by TIA/EIA-568-C.2.
 - b. Conductors:
 - 1) 24 AWG solid bare copper conductors.
 - c. Insulation:
 - 1) Polyolefin.
 - 2) 4 non-bonded twisted pair cables formed into a cable core.
 - d. Color code:
 - 1) Pair 1: White/blue stripe and blue.
 - 2) Pair 2: White/orange stripe and orange.
 - 3) Pair 3: White/green stripe and green.
 - 4) Pair 4: White/brown stripe and brown.
 - e. Outer jacket:
 - 1) PVC with ripcord.
 - f. Electrical characteristics:
 - 1) Frequency range: 0.772-100 MHz.
 - 2) Attenuation: 32.1 dB/100 m.
 - 3) Near-end crosstalk (NEXT): 39.3 dB.
 - 4) Power sum NEXT: 37.3 dB.
 - 5) Attenuation to crosstalk ratio (ACR): 7.2 dB.
 - 6) Power sum attenuation to crosstalk ratio (PSACR): 5.3 dB/100 m.
 - 7) Equal level far-end crosstalk (ELFEXT): 22.8 dB.
 - 8) Power sum ELFEXT: 19.8 dB/100 m.
 - 9) Return loss: 17.3 dB.
 - 10) Propagation delay: 537 ns/100 m.
 - 11) Delay skew: 45 ns/100 m.
 - 12) Propagation delay (skew), max: 2.5 ns/100 m.

2.05 EQUIPMENT

Not Used.

2.06 COMPONENTS

Not Used.

2.07 ACCESSORIES

- A. Wire ties:
 - 1. One of the following or equal:
 - a. T&B "Ty-Rap" cable ties.
 - b. Panduit cable ties.

2.08 MIXES

Not Used.

2.09 FABRICATION

Not Used.

2.10 FINISHES

Not Used.

2.11 SOURCE QUALITY CONTROL

- A. Assembly and testing of cable shall comply with the applicable requirements of ICEA S-95-658-1999.
- B. Test Type XHHW-2 in accordance with the requirements of UL 44.

PART 3 EXECUTION

3.01 EXAMINATION

Not Used.

3.02 PREPARATION

Not Used.

3.03 INSTALLATION

- A. As specified in Section 16050.
- B. Color-coding:
 - 1. Color-coding shall be consistent throughout the facility.

2. The following color code shall be followed for all 240/120 volt and 208/120 volt systems:
 - a. Phase A - Black.
 - b. Phase B - Red.
 - c. Phase C - Blue.
 - d. Single phase system - Black for one hot leg, red for the other.
 - e. Neutral - White.
 - f. High phase or wild leg - Orange.
 - g. Equipment ground - Green.
 3. The following color code shall be followed for all 480/277 volt systems:
 - a. Phase A - Brown.
 - b. Phase B - Orange.
 - c. Phase C - Yellow.
 - d. Neutral - Gray.
 - e. Equipment ground - Green.
 4. The following color code shall be followed for all 120 VAC control wiring:
 - a. Power - Red.
 - b. Neutral - White.
 5. The following color code shall be followed for all general purpose DC control circuits:
 - a. Grounded conductors - White with blue stripe.
 - b. Ungrounded conductors - Blue.
 6. Switch legs shall be violet. Three-way switch runners shall be pink.
 7. Wires in intrinsically safe circuits shall be light blue.
 8. Wire colors shall be implemented in the following methods:
 - a. Wires manufactured of the desired color.
 - b. Continuously spiral wrap the first 6 inches of the wire from the termination point with colored tape:
 - 1) Colored tape shall be wrapped to overlap 1/2 of the width of the tape.
- C. Properly coat wires and cables with pulling compound before pulling into conduits:
1. For all Number 4 AWG and larger, use an approved wire-pulling lubricant while cable is being installed in conduit:
 - a. Ideal Products.
 - b. Polywater Products.
 - c. 3M Products.
 - d. Greenlee Products.
 - e. Or equal as recommended by cable manufacturer.
 - f. Do not use oil, grease, or similar substances.
- D. Neatly arrange and lace conductors in all switchboards, panelboards, pull boxes, and terminal cabinets by means of wire ties:
1. Do not lace wires in gutter or panel channel.
 2. Install all wire ties with a flush cutting wire tie installation tool:
 - a. Use a tool with an adjustable tension setting.
 3. Do not leave sharp edges on wire ties.
- E. Terminate stranded conductors on equipment box lugs such that all conductor strands are confined within the lug:
1. Use ring type lugs if box lugs are not available on the equipment.

- F. Splices:
1. Provide continuous circuits from origin to termination whenever possible:
 - a. Obtain Engineer's approval prior to making any splices.
 2. Lighting and receptacle circuit conductors may be spliced without prior approval from the Engineer.
 3. Where splices are necessary because of extremely long wire or cable lengths that exceed standard manufactured lengths:
 - a. Splice box NEMA rating requirements as specified in Section 16050.
 - b. Make splices in labeled junction boxes for power conductors.
 - c. Make splices for control and instrument conductors in terminal boxes:
 - 1) Provide terminal boards with setscrew pressure connectors, with spade or ring lug connectors.
 4. Leave sufficient slack at junction boxes and termination boxes to make proper splices and connections. Do not pull splices into conduits.
 5. Install splices with compression type butt splices and insulate using a heat-shrink sleeve:
 - a. In NEMA Type 4 or NEMA Type 4X areas, provide heat-shrink sleeves that are listed for submersible applications.
 6. Splices in below grade pull boxes, in any box subject to flooding, and in wet areas shall be made waterproof using:
 - a. A heat shrink insulating system listed for submersible applications.
 - b. Or an epoxy resin splicing kit.
- G. Apply wire markers to all wires at each end after being installed in the conduit and before meg-ohm testing and termination.
- H. Instrumentation class cable:
1. Install instrumentation class cables in separate raceway systems from power cables:
 - a. Install instrument cable in metallic conduit within non-dedicated manholes or pull boxes.
 - b. Install cable without splices between instruments or between field devices and instrument enclosures or panels.
 2. Do not make intermediate terminations, except in designated terminal boxes as indicated on the Drawings.
- I. Multi-conductor cable:
1. Where cable is not routed in conduit with a separate ground conductor, use one conductor in the cable as a ground conductor:
 - a) Use an internal ground conductor, if it is no smaller than as indicated on the Drawings and in accordance with NEC requirements for equipment ground conductor size.
 - b) Where 2 parallel cables are used, and the internal ground conductor in each cable does not meet NEC requirements for the combined circuit, use 4-conductor cable, with one of the full-sized conductors serving as ground.
- J. Signal cable:
1. Separate and isolate electrical signal cables from sources of electrical noise and power cables by minimum 12 inches.

- K. Wiring allowances:
 - 1. Equipment locations may vary slightly from the drawings. Include an allowance for necessary conductors and terminations for motorized equipment, electrical outlets, fixtures, communication outlets, instruments, and devices within 10 linear feet of locations indicated on the Drawings.

3.04 ERECTION, INSTALLATION, APPLICATION, CONSTRUCTION

Not Used.

3.05 REPAIR/RESTORATION

Not Used.

3.06 RE-INSTALLATION

Not Used.

3.07 COMMISSIONING AND PROCESS START-UP

- A. As specified in Section 01756.

3.08 FIELD QUALITY CONTROL

- A. As specified in Section 16050 and 11289.

3.09 ADJUSTING

Not Used.

3.10 CLEANING

Not Used.

3.11 PROTECTION

- A. As specified in Section 16050.

3.12 SCHEDULES

Not Used.

END OF SECTION

SECTION 16150

LOW VOLTAGE WIRE CONNECTIONS

1.01 SUMMARY

- A. Section includes:
 - 1. Wire connecting devices.
 - 2. Terminations.
 - 3. Splices.

- B. Related sections:
 - 1. The Contract Documents are complementary; what is called for by one is as binding as if called for by all.
 - 2. It is the Contractor's responsibility for scheduling and coordinating the Work of subcontractors, vendors, and other individuals or entities performing or furnishing any of Contractor's Work.
 - 3. The following sections are related to the Work described in this Section. This list of related sections is provided for convenience only and is not intended to excuse or otherwise diminish the duty of the Contractor to see that the completed Work complies accurately with the Contract Documents:
 - a. Section 01330 - Submittal Procedures.
 - b. Section 01756 - Commissioning and Process Start-up.
 - c. Section 16050 - Common Work Results for Electrical.
 - d. Section 16123 - 600-Volt or Less Wires and Cables.

1.02 REFERENCES

- A. As specified in Section 16050.

- B. ASTM International (ASTM):
 - 1. D 3005 – Standard Specification for Low-Temperature Resistant Vinyl Chloride Plastic Pressure-Sensitive Electrical Insulating Tape.

- C. CSA International (CSA):
 - 1. C22.2 - No.197-M1983 (R2208) - PVC Insulating Tape.

- D. Underwriters Laboratories, Inc. (UL):
 - 1. 510 - Standard for Polyvinyl Chloride, Polyethylene, and Rubber Insulating Tape.

1.03 DEFINITIONS

- A. As specified in Section 16050.

1.04 SYSTEM DESCRIPTION

- A. Provide a complete system of wiring connectors, terminators, fittings, etc. for a complete wiring system suitable for the cables and conductors used.

1.05 SUBMITTALS

- A. Furnish submittals as specified in Sections 01330 and 16050.
- B. Product data:
 - 1. Catalog cut sheets.
 - 2. Installation instructions.

1.06 QUALITY ASSURANCE

- A. As specified in Section 16050.
- B. All materials shall be UL listed.

1.07 DELIVERY, STORAGE, AND HANDLING

- A. As specified in Section 16050.

1.08 PROJECT OR SITE CONDITIONS

- A. As specified in Section 16050.

1.09 SEQUENCING

Not Used.

1.10 SCHEDULING

Not Used.

1.11 WARRANTY

- A. As specified in Section 16050.

1.12 SYSTEM START-UP

- A. As specified in Section 16050.

1.13 OWNER'S INSTRUCTIONS

Not Used.

1.14 MAINTENANCE

Not Used.

PART 2 PRODUCTS

2.01 MANUFACTURERS

- A. Manufacturers for each type of technology are specified with the equipment in this Section.

2.02 EXISTING PRODUCTS

Not Used.

2.03 MATERIALS

Not Used.

2.04 MANUFACTURED UNITS

Not Used.

2.05 EQUIPMENT

- A. Control connections:
 - 1. Use insulated ring type wire terminators for connections to all screw terminals:
 - a. With chamfered/funneled terminal barrel entry.
 - b. Deep internal serrations.
 - c. Long barrel design to reduce electrical resistance and increased insulator-barrel surface area to ensure that the insulator remains in contact with the barrel.
 - d. Electroplated-tin copper conductor.
 - e. Manufacturer: The following or equal:
 - 1) Thomas and Betts, Stakon.
 - 2. For process equipment connections work from manufacturer's drawings.
- B. Joints, splices, taps, and connections:
 - 1. 600-volt conductors:
 - a. Use solderless connectors.
 - b. Use only plated copper alloy connectors or lugs:
 - 1) Aluminum connectors or lugs are not acceptable for copper conductors.
 - c. Under those specific conditions where aluminum conductors have been allowed or are specified then the connectors for aluminum conductors shall be specifically designed for that purpose.
 - d. For wire Number 10 AWG and smaller use compression splice caps, with insulating caps:
 - 1) Manufacturer: The following or equal:
 - a) Buchanan 2006S or 2011S, with 2007 or 2014 insulating caps.
 - e. For wire Number 8 AWG and larger, use heavy duty copper compression connectors:
 - 1) Manufacturer: One of the following or equal:
 - a) Burndy.
 - b) Thomas and Betts.
 - f. Heat shrink tubing:
 - 1) Suitable for indoors, outdoors, overhead, direct burial or submerged applications.
 - 2) Minimum shrink ratio: 4 to 1.
 - 3) Continuous operating temperature: -55 degrees Celsius to 110 degrees Celsius.
 - 4) Internally applied adhesive sealant.

- 5) Cross-linked polyolefin:
 - a) Manufacturers, one of the following or equal:
 - (1) 3M ITCSN.
 - (2) Thomas & Betts Shrink-Kon.
 2. Instrumentation class cable splices:
 - a. Suitable for indoor, outdoors, weather exposed, direct buried, or submersed applications.
 - b. Utilizing an epoxy, polyurethane, and re-enterable compounds.
 - c. For use with shielded or unshielded plastic- and rubber-jacketed, signal, control, and power cables rated up to 1 kilovolt.
 - d. Two-part mold body with tongue and groove seams and built in spacer webbing.
 - e. Manufacturer: The following or equal:
 - 1) 3M - Scotchcast 72-N.
- C. Insulating tape:
1. General purpose insulating tape:
 - a. Minimum 7 mil vinyl tape.
 - b. Suitable for application in an ambient of -18 degrees Celsius (0 degrees Fahrenheit).
 - c. Operating range up to 105 degrees Celsius (220 degrees Fahrenheit).
 - d. Flame retardant, hot- and cold- weather resistant, UV resistant.
 - e. For use as a primary insulation for wire cable splices up to 600 VAC.
 - f. Meeting and complying with:
 - 1) ASTM D 3005 Type I.
 - 2) UL 510.
 - 3) CSA C22.2.
 - g. Manufacturer: The following or equal:
 - 1) 3M - Scotch Number Super 33+.
 2. General-purpose color-coding tape:
 - a. Minimum 7 mil vinyl tape.
 - b. Suitable for application on PVC and polyethylene jacketed cables.
 - c. For use indoors and outdoors in weather protected enclosures.
 - d. Available with the following colors:
 - 1) Red.
 - 2) Yellow.
 - 3) Blue.
 - 4) Brown.
 - 5) Gray.
 - 6) White.
 - 7) Green.
 - 8) Orange.
 - 9) Violet.
 - e. For use as phase identification, marking, insulating, and harnessing.
 - f. Meeting and complying with:
 - 1) UL 510.
 - 2) CSA C22.2.
 - g. Manufacturer the following or equal:
 - 1) 3M - Scotch Number 35.

2.06 COMPONENTS

Not Used.

2.07 ACCESSORIES

Not Used.

2.08 MIXES

Not Used.

2.09 FABRICATION

Not Used.

2.10 FINISHES

Not Used.

2.11 SOURCE QUALITY CONTROL

Not Used.

PART 3 EXECUTION

3.01 EXAMINATION

Not Used.

3.02 PREPARATION

Not Used.

3.03 INSTALLATION

- A. As specified in Section 16050.
- B. Load connections:
 - 1. Connect loads to the circuits as indicated. Color-code all branch circuits as specified in Section 16123.
- C. Zero to 600-volt systems:
 - 1. Make all connections with the proper tool and die as specified by the device manufacturer.
 - 2. Use only tooling and dies manufactured by the device manufacturer.
 - 3. Insulate all connections and splices with Scotch 33+ tape and Scotchfill, or pre-molded plastic covers, or heat shrink tubing and caps.
 - 4. Number all power and control wires before termination.

- D. Motor connections (600 volts and below):
 - 1. Terminate wires with compression type ring lugs at motors.
 - 2. Connection at both the motor leads and the machine wires shall have ring type compression lugs.
 - 3. Cover bolted connectors with a heat shrinkable, cross-linked polyolefin material formed as a single opening boot:
 - a. In damp and wet locations, use a complete kit containing mastic that shall seal out moisture and contamination.
 - b. Shrink cap with low heat as recommended by manufacturer.
 - 4. Wire markers shall be readable after boot installation.
 - 5. Manufacturer: The following or equal:
 - a. Raychem MCK.

3.04 ERECTION, INSTALLATION, APPLICATION, CONSTRUCTION

Not Used.

3.05 REPAIR/RESTORATION

Not Used.

3.06 RE-INSTALLATION

Not Used.

3.07 COMMISSIONING AND PROCESS START-UP

- A. As specified in Section 01756.

3.08 FIELD QUALITY CONTROL

- A. As specified in Section 16050.

3.09 ADJUSTING

Not Used.

3.10 CLEANING

Not Used.

3.11 PROTECTION

- A. As specified in Section 16050.

3.12 SCHEDULES

Not Used.

END OF SECTION

SECTION 16494
LOW VOLTAGE FUSES

PART 1 GENERAL

1.01 SUMMARY

- A. Section includes:
 - 1. Fuses: 600 volt class and lower.

- B. Related sections:
 - 1. The Contract Documents are complementary; what is called for by one is as binding as if called for by all.
 - 2. It is the Contractor's responsibility for scheduling and coordinating the Work of subcontractors, vendor, and other individuals or entities performing or furnishing any of Contractor's Work.
 - 3. The following sections are related to the Work described in this Section. This list of related sections is provided for convenience only and is not intended to excuse or otherwise diminish the duty of the Contractor to see that the completed Work complies accurately with the Contract Documents:
 - a. Section 01330 - Submittal Procedures.
 - b. Section 01756 - Commissioning and Process Start-up.
 - c. Section 16050 - Common Work Results for Electrical.

1.02 REFERENCES

- A. As specified in Section 16050.

1.03 DEFINITIONS

- A. As specified in Section 16050.

1.04 SYSTEM DESCRIPTION

- A. Fuses for overcurrent protection and/or current limiting applications as indicated on the Drawings.

1.05 SUBMITTALS

- A. Furnish submittals as specified in Sections 01330 and 16050.

- B. Product data:
 - 1. Catalog cut sheets.
 - 2. Complete fuse schedule.
 - 3. Manufacturer original 11-inch by 17-inch, time current curves for all fuses furnished.

- C. Shop drawings:
 - 1. Include drawings of spare fuse cabinets.

1.06 QUALITY ASSURANCE

- A. As specified in Section 16050.
- B. All low voltage fuses shall be UL listed and labeled.

1.07 DELIVERY, STORAGE, AND HANDLING

- A. As specified in Section 16050.

1.08 PROJECT OR SITE CONDITIONS

- A. As specified in Section 16050.

1.09 SEQUENCING

Not Used.

1.10 SCHEDULING

Not Used.

1.11 WARRANTY

- A. As specified in Section 16050.

1.12 SYSTEM START-UP

- A. As specified in Section 16050.

1.13 OWNER'S INSTRUCTIONS

Not Used.

1.14 MAINTENANCE

- A. Spare parts:
 - 1. Provide 3 spare fuses for each size and type used or supplied under any Section of the Contract Documents.
 - 2. Provide spare fuse cabinet(s):
 - a. Metal cabinet with hinged door and shelves or fuse holders.
 - b. Gray enamel finish.
 - c. Mount near equipment and label "Spare Fuses" on face of cabinet.
 - d. Suitable pocket inside door of each cabinet with typewritten spare fuse inventory in clear plastic protective insert.
 - e. Provide as many cabinets as required to hold entire spare fuse inventory.

PART 2 PRODUCTS

2.01 MANUFACTURERS

- A. One of the following or equal:
 - 1. Ferraz Shawmut.
 - 2. Littelfuse.
 - 3. Bussmann.

2.02 EXISTING PRODUCTS

Not Used.

2.03 MATERIALS

Not Used.

2.04 MANUFACTURED UNITS

- A. General:
 - 1. Provide durable, readily visible label inside each fuse enclosure, clearly indicating the correct type, size, and ratings of replacement fuse:
 - a. Label shall not cover or interfere with equipment manufacturer's instructions.
 - 2. Affix a label indicating recommended torque for fuse mounting bolts or studs to the inside of fuse access doors.
 - 3. To ensure selective coordination of protective devices:
 - a. Provide fuses for new facilities by the same manufacturer.
 - b. Provide fuses for renovations of the same manufacturer as existing fuses.
 - 4. Provide fuses rated for the voltage and available short circuit current at which they are applied.
- B. Fusing of control circuits:
 - 1. Provide:
 - a. RK1 fuses installed in UL listed Class CC fuse blocks as specified in the Contract Documents.
 - 2. Provide minimum protection for control circuits in accordance with the latest revision of UL Standard 508 for Industrial Control.
 - 3. Fuse both the primary and secondary circuit of control power transformers:
 - a. Fuse ratings shall be in accordance with NEC requirements.

2.05 EQUIPMENT

Not Used.

2.06 COMPONENTS

Not Used.

2.07 ACCESSORIES

Not Used.

2.08 MIXES

Not Used.

2.09 FABRICATION

Not Used.

2.10 FINISHES

Not Used.

2.11 SOURCE QUALITY CONTROL

Not Used.

PART 3 EXECUTION

3.01 EXAMINATION

Not Used.

3.02 PREPARATION

Not Used.

3.03 INSTALLATION

- A. As specified in Section 16050.
- B. General:
 - 1. Install fuses properly aligned, electrically and mechanically secure.
 - 2. Evenly torque mounting bolts and nuts to ASTM recommendations for type and diameter of mounting bolts or studs provided.
 - 3. Paralleling of fuses is not permitted.
 - 4. Install fuses so that the fuse nameplate and rating are easily readable in the equipment.
- C. Replace fuses, on all phases, for any fuses that opened during start-up and testing.
- D. After completion of testing, deliver spare fuses in quantities specified:
 - 1. Fuses shall be new, in manufacturer's original packaging, and stored in a clean, dry location.
- E. Install spare fuse cabinets where instructed by the Owner.

3.04 ERECTION, INSTALLATION, APPLICATION, CONSTRUCTION

Not Used.

3.05 REPAIR/RESTORATION

Not Used.

3.06 RE-INSTALLATION

Not Used.

3.07 COMMISSIONING AND PROCESS START-UP

A. As specified in Section 01756.

3.08 FIELD QUALITY CONTROL

A. As specified in Section 16050.

3.09 ADJUSTING

Not Used.

3.10 CLEANING

A. As specified in Section 16050.

3.11 PROTECTION

A. As specified in Section 16050.

3.12 SCHEDULES

Not Used.

END OF SECTION

SECTION 17055

PACKAGED CONTROL SYSTEM

PART 1 GENERAL

1.01 SUMMARY

A. Section includes:

1. General requirements for a Master Control Panel (MCP) designed to monitor and control all skids and ancillary equipment furnished for each skid, local control panels at each skid, local control panels for other furnished equipment, and field instruments required for a complete package control system.

B. Related sections:

1. Section 01330 - Submittal Procedures.
2. Section 01410 - Regulatory Requirements.
3. Section 01612 - Seismic Design Criteria.
4. Section 01756 - Commissioning.

1.02 REFERENCES

A. Code compliance:

1. As specified in Section 01410:
 - a. The publications are referred to in the text by basic designation only. The latest edition accepted by the Authority Having Jurisdiction of referenced publications in effect at the time of Bid governs.
2. The following codes and standards are hereby incorporated into these Specifications:
 - a. Institute of Electrical and Electronics Engineers:
 - 1) C62.41.1 - IEEE Guide on the Surge Environment in Low-Voltage (1000V and less) AC Power Circuits.
 - b. International Society of Automation (ISA):
 - 1) 5.4 - Instrument Loop Diagrams.
 - 2) 20 - Specification Forms for Process Measurement and Control Instruments, Primary Elements, and Control Valves.
 - c. National Electrical Manufacturer's Association (NEMA):
 - 1) 250 - Enclosures for Electrical Equipment (1,000 Volts Maximum).
 - d. National Fire Protection Association (NFPA).
 - e. Underwriters Laboratories Inc. (UL):
 - 1) 508C - Power Conversion Equipment.
 - 2) 489 - Molded-Case Circuit Breakers, Molded-Case Switches, and Circuit-Breaker Enclosures.
 - 3) 913 - Standard for Intrinsically Safe Apparatus and Associated Apparatus for Use in Class I, II, III, Division 1, Hazardous (Classified) Locations.
 - 4) 1283 - Standard for Electromagnetic Interference Filters.
 - 5) 1449 - Transient Voltage Surge Suppressors.

1.03 DEFINITIONS

- A. Definitions of terms and other electrical and instrumentation considerations as set forth in the:
1. Factory Mutual or FM Global (FM).
 2. Institute of Electrical and Electronic Engineers (IEEE).
 3. InterNational Electrical Testing Association (NETA).
 4. International Electrotechnical Commission (IEC).
 5. International Organization for Standardization (ISO).
 6. International Society of Automation (ISA).
 7. National Electrical Code (NEC).
 8. National Fire Protection Association (NFPA).
 9. National Institute of Standards and Technology (NIST).
 10. Underwriter Laboratories (UL).
- B. NEMA:
1. Type 1 enclosure in accordance with NEMA 250.
 2. Type 3R enclosure in accordance with NEMA 250.
 3. Type 4 enclosure in accordance with NEMA 250.
 4. Type 4X enclosure in accordance with NEMA 250.
 5. Type 6 enclosure in accordance with NEMA 250.
 6. Type 6P enclosure in accordance with NEMA 250.
 7. Type 12 enclosure in accordance with NEMA 250.
- C. Specific definitions:
1. Control circuit: Any circuit operating at 120 volts alternating current (AC) or direct current (DC) or less, whose principal purpose is the conveyance of information (including performing logic) and not the conveyance of energy for the operation of an electrically powered device.
 2. Panel: An instrument support system that may be either a flat surface, a partial enclosure, or a complete enclosure for instruments and other devices used in process control systems. Unless otherwise specified or clearly indicated by the context, the term "panel" in these Contract Documents is interpreted as a general term, which includes flat surfaces, enclosures, cabinets and consoles.
 3. Power circuit: Any circuit operating at 90 volts (AC or DC) or more, whose principal purpose is the conveyance of energy for the operation of an electrically powered device.
 4. Signal circuit: Any circuit operating at less than 50 volts AC or DC, which conveys analog information or digital communications information.
 5. Digital Bus: A communication network, such as Profibus, Foundation Fieldbus, or DeviceNet, allowing instruments and devices to transmit data, control functions and diagnostic information.
 6. 2-Wire transmitter (loop powered): A transmitter that derives its operating power supply from the signal transmission circuit and requires no separate power supply connections. As used in this Section, 2-wire transmitter refers to a transmitter that provides 4 to 20 mA current regulation of a signal in a series circuit with an external 24 VDC driving potential:
 - a. Field Bus Communications signal or both.
 7. Powered transmitters: A transmitter that requires a separate power source (120 VAC, 240 VAC, etc.) in order for the transmitter to develop its signal. As used in this Section, the produced signal may either be a 4 to 20 mA current signal, a Digital Bus communications signal or both.

8. Hardwired control: Control circuitry that does not utilize software to initiate functionality.
9. Hardwired interlocks: A safety or protective feature that will interrupt operation of the equipment in all operating modes with no required operator intervention.
10. Software interlocks: A safety or protective feature that will interrupt operation of the equipment when the RTU has control.
11. The term “panel” in this Section is interchangeable with the term “enclosure.”

D. Acronym definitions:

1. CCS: The PCS central computer system (CCS) consisting of computers and software. The personal computer-based hardware and software system that includes the operator interface, data storage, data retrieval, archiving, alarming, historian, reports, trending, and other higher level control system software and functions.
2. DPDT: Double-pole, double-throw.
3. ES: Enterprise system: Computer based communications or data sharing system utilized for non-process control functions such as E-mail, sharing files, creating documents, etc.
4. FAT: Factory acceptance test also known as Source Test.
5. HART: Highway addressable remote transducer.
6. HOA: Hand-Off-Auto control function that is totally PLC based. In the Hand mode, equipment is started or stopped, valves are opened or closed through operator direction under the control of the PLC software. In the Auto mode, equipment is started or stopped and valves are opened or closed through a control algorithm within the PLC software. In the Off mode, the equipment is prohibited from responding from the PLC control.
7. HMI: Human machine interface is a software application that presents information to an operator or user about the state of a process, and to accept and implement the operators control instructions. Typically information is displayed in a graphical format.
8. ICSC: Instrumentation and control system contractor: Subcontractor who specializes in the design, construction, fabrication, software development, installation, testing, and commissioning of industrial instrumentation and control systems.
9. IJB: Instrument junction boxes: A panel designed with cord sets to easily remove, replace or relocate instrument signals.
10. I/O: Input/Output.
11. IP: Internet protocol or ingress protection.
12. LCP: Local control panel: Operator interface panel that may contain an HMI, pilot type control devices, operator interface devices, control relays, etc. and does not contain a PLC or RIO.
13. LAN: Local area network: A control or communications network that is limited to the physical boundaries of the facility.
14. LOI: Local Operator Interface is an operator interface device consisting of an alphanumeric or graphic display with operator input functionality. The LOI is typically a flat panel type of display mounted on the front of an enclosure with either a touch screen or tactile button interface.
15. LOR: Local-Off-Remote control function. In the Remote mode, equipment is started or stopped, and valves are opened or closed through the PLC based upon the selection of the HOA. In the Local mode, equipment is started or stopped, valves are opened or closed based upon hardwired control circuits completely independent of the PLC with minimum interlocks and permissive

- conditions. In the Off mode, the equipment is prohibited from responding to any control commands.
16. NJB: Network junction box. An enclosure that contains multiple access points to various networks within the facility. Networks could be Ethernet, Ethernet/IP, Fieldbus, RIO etc.
 17. P&ID: Process and instrumentation diagram.
 18. PC: Personal computer.
 19. PCIS: Process control and instrumentation system: Includes the entire instrumentation system, the entire control system, and all of the Work specified in the Instrumentation and Control Specifications and depicted on the Instrumentation Drawings.
 20. PCM: Process control module: An enclosure containing any of the following devices: PLC, RTU, or RIO.
 21. PCS: Process Control System: A general name for the computerized system that gathers and processes data from equipment and sensors and applies operational controls to the process equipment. It includes the PLCs and/or RIOs, LOIs, HMIs, both LCPs, VCPs and all data management systems accessible to staff.
 22. PJB: Power junction box: An enclosure with terminal blocks that distribute power to multiple instruments.
 23. PLC: Programmable logic controller.
 24. RIO: Remote I/O device for the PLC consisting of remote I/O racks, or remote I/O blocks.
 25. RTU: Remote telemetry unit: A controller typically consisting of a PLC, and a means for remote communications. The remote communications devices typically are radios, modems, etc.
 26. SCADA: Supervisory control and data acquisition system: A general name for the computerized system that gathers and processes data from sensors and equipment located outside of the facility, such as wells, lift stations, metering stations etc.
 27. SPDT: Single-pole, double-throw.
 28. SPST: Single-pole, single-throw.
 29. UPS: Uninterruptible power supply.
 30. VCP: Vendor control panel: Control panels that are furnished with particular equipment by a SUPPLIER or vendor other than the ICSC. These panels may contain PLCs, RIO, LOI, HMI, etc.
 31. WAN: Wide area network: A control or communications network that extends beyond the physical boundaries of the facility.

1.04 SYSTEM DESCRIPTION

- A. Master control panel (MCP):
 1. PLC processor, power supply, I/O backplanes, I/O modules and communications modules sized for connected I/O and required spares.
 2. LOI on the face of the MCP enclosure for monitoring and control of the package control system.
 3. Ethernet communication equipment to provide communications with plant PCS system.
 4. Uninterruptable power supply.

5. The MCP shall exercise control over all aspects of the package control system.
 6. All PLC and LOI programming required for fully functional package control system.
- B. Other control panels:
1. Provide each skid or train with a control panel.
 2. Provide other control panels at the supplier's discretion.
 3. I/O modules and equipment necessary to interface with the MCP.
 4. Additional LOIs on individual unit skid local control panels at the supplier's discretion.
- C. Field instruments for process and equipment monitoring.

1.05 SUBMITTALS

- A. General:
1. Submit as specified in Section 01330.
 2. Furnish submittals that are fully indexed with a tabbed divider for every component.
 3. Sequentially number pages within the tabbed sections. Submittals and Operations and Maintenance manuals that are not fully indexed and tabbed with sequentially numbered pages, or are otherwise unacceptable, will be returned without review.
 4. Edit all submittals and operation and maintenance manuals so that the submittal specifically applies to only the equipment furnished. Neatly cross out all extraneous text, options, models, etc. that do not apply to the equipment being furnished, so that the information remaining is only applicable to the equipment being furnished.
- B. Pre-bid information:
1. Suppliers of packaged systems shall provide sufficient information to the Contractor to allow an adequate estimate of the Electrical and Instrumentation Work associated with the installation of the packaged system.
 2. To the extent practical, packaged systems shall be factory assembled and wired. Information on packing splits and other anticipated field wiring requirements shall be provided to the Contractor prior to the bid.
 3. The Contractor shall be responsible to obtain the necessary information to accurately estimate the electrical connections to the packaged system equipment.
- C. Product data:
1. General:
 - a. Submitted for non-custom manufactured material specified in this and other sections and indicated on shop drawings.
 - b. Furnish sufficient information to evaluate the suitability of the proposed material or equipment for the intended use, and for compliance with these Specifications.
 - c. Include:
 - 1) Catalog cuts.
 - 2) Bulletins.
 - 3) Brochures.

- 4) Quality photocopies of applicable pages from these documents.
 - 5) Identify on the data sheets the project name, applicable specification section, and paragraph.
 - 6) Identify model number and options for the actual equipment being furnished.
- d. Legibly cross out options that do not apply or equipment not intended to be supplied.
2. Material and equipment schedules:
 - a. Furnish a complete schedule and/or matrix of all materials, equipment, apparatus, and instruments that are proposed:
 - 1) Include sizes, names of manufacturers, catalog numbers, and such other information required to identify the items.
 3. Instrument data sheets:
 - a. Furnish fully completed data sheets, both electronically in Microsoft Word or Excel and in hardcopy, for each instrument and component according to ISA 20. Include the following information on the data sheet:
 - 1) Component functional description specified in this Section and indicated on the Drawings.
 - 2) Manufacturers model number or other product designation.
 - 3) Tag number specified in this Section and indicated on the Drawings.
 - 4) System or loop of which the component is a part.
 - 5) Location or assembly at which the component is to be installed.
 - 6) Input and output characteristics.
 - 7) Scale range with units and multiplier.
 - 8) Requirements for electric supply.
 - 9) Requirements for air supply.
 - 10) Power consumption.
 - 11) Response timing.
 - 12) Materials of construction and of component parts that are in contact with, or otherwise exposed to, process media, and or corrosive ambient air.
 - 13) Special requirements or features, such as specifications for ambient operating conditions.
 - 14) Features and options that are furnished.
- D. Shop drawings:
1. General:
 - a. Show all interfaces between any of the following: instruments, vendor control panels, electrical equipment, control valves, and other equipment related to the control work provided.
 2. Shop drawing requirements:
 - a. Front, side, and, rear elevations, and top and bottom views, showing all dimensions.
 - b. Locations of conduit entrances and access plates.
 - c. Component layout and identification.
 - d. Schematic and wiring diagrams with wire numbers and terminal identification.
 - e. Connection diagrams, terminal diagrams, internal wiring diagrams, conductor size, etc.
 - f. Anchoring method and leveling criteria, including manufacturer's recommendations for the seismic specified in Section 01612.
 - g. Weight.

- h. Finish.
 - i. Nameplates with legends:
 - 1) Temperature limitations, as applicable.
3. Loop drawings:
- a. Submit loop drawings for every analog, discrete, signal and control circuit:
 - 1) Provide a loop drawing submittal that completely defines and documents the contents of each monitoring, alarming, interlock, and control loop for supplier provided equipment.
 - b. Show every instrument and I/O point on at least one loop diagram.
 - c. Provide a complete index in the front of each bound volume:
 - 1) Index the loop drawings by systems or process areas.
 - d. Provide drawings showing definitive diagrams for every instrumentation loop system:
 - 1) Show and identify each component of each loop or system using requirements and symbols from ISA S5.4 as amended by the Contract Drawings, as defined by the most recent revision in ISA.
 - 2) Furnish a separate drawing sheet for each system or loop diagram.
 - e. In addition to the ISA S5.4 requirements, show the following details:
 - 1) Functional name of each loop.
 - 2) Reference name, drawing, and loop diagram numbers for any signal continuing off the loop diagram sheet.
 - 3) Show all terminal numbers, regardless of the entity providing the equipment.
 - 4) MCC panel, circuit, and breaker numbers for all power feeds to the loops and instrumentation.
 - 5) Designation of and, if appropriate, terminal assignments associated with, every manhole, pull-box, junction box, conduit, and panel through which the loop circuits pass.
 - 6) If a circuit is continued on another drawing show the name and number of the continuation drawing on the loop drawing. Provide complete references to all continuation drawings.
4. Control panel drawings:
- a. Layout drawings:
 - 1) Submit panel, enclosure, and cabinet layout drawings for all items provided.
 - 2) As a minimum, include the following information:
 - a) To scale front, side, and plan views.
 - b) Dimensions.
 - c) Interior and exterior arrangements.
 - d) Mounting information, including conduit entrance location.
 - e) Finish data.
 - f) Tag number and functional name of items mounted in and on each panel, console, and cabinet.
 - g) Nameplate legend including text, letter size, and colors.
 - b. Wiring and piping diagrams:
 - 1) Submit panel wiring and piping diagrams for every panel that contains wiring and/or piping.
 - 2) Include the following information:
 - a) Name of panel.
 - b) Wiring and piping sizes and types.
 - c) Terminal strip numbers.
 - d) Wire tags and labels.

- e) Functional name and manufacturer's designation for items to which wiring and piping are connected.
 - f) Electrical control schematics in accordance with ANSI standards.
 - c. Calculations:
 - 1) Provide installation details based on calculated shear and tension forces:
 - a) Calculations shall be signed and sealed by a Professional Engineer licensed in the state where the cabinets and panels will be installed.
 - 2) For assembled enclosures and other equipment with a weight of 200 pounds or more, provide calculations for:
 - a) Weight including panel internal components.
 - b) Seismic forces and overturning moments.
 - c) Shear and tension forces in connections.
 - 3) Cooling calculations, to include but not limited to:
 - a) Highest expected ambient temperature for the enclosure's location.
 - b) Internal heat load.
 - c) Exposure to direct sunlight.
 - d) Dimensions of the enclosure in inches.
 - e) Maximum desired temperature inside the enclosure.
 - d. Seismic panel construction:
 - 1) Seismic anchorage: Provide seismic design calculations and installation details for anchorage of all panels, enclosures, consoles, etc. to meet seismic requirements as specified in Section 01612:
 - a) Stamped by a Professional Engineer registered in the state where the Project is being constructed.
 - 2) For floor mounted free standing panels weighing 200 pounds or more (assembled, including contents), submit calculations, data sheets, and other information to substantiate that panel, base, and framing meet minimum design strength requirements and seismic requirements at the project site. Calculations shall be signed and sealed by a Professional Engineer.
 - 5. Schematic diagrams:
 - a. Submit schematic diagrams for all electrical equipment in ladder diagram format.
 - b. Include device and field connection terminal numbers on all schematic diagrams.
- E. Process control and LOI software submittal:
1. A complete listing of the PLC system point I/O database:
 - a. Include for each data point, relevant parameters such as range, contact orientation, limits, incremental limits, I/O card byte, I/O hardware address, and PLC assignment.
 - b. Organize on a site-by-site basis, separate by point type.
 - c. In addition to the active I/O points, list the implemented spare I/O points and the available I/O points remaining on each card, as well as other defined future points specified or shown.
 2. Preliminary LOI screens, including pop-ups, trends, and alarm screens. Provide electronic and hard copy.

3. Final LOI screens for use by the ICSC in developing graphic screens for WTP PCS system. Provide electronic and hard copy.
4. Provide a complete, documented listing of all PLC codes.

F. Testing:

1. For each test specified in this Section, prepare and submit complete test plans, test procedures, test forms, test binders, and test reports, and other submittals, as specified below.
2. Submit manufacturer's certifications and manufacturer's field reports where required.
3. Submit Test plans, procedures, forms, and binders for approval by the Engineer before scheduling or performing tests.
4. Additional test form and test procedure requirements are specified with individual test requirements.

1.06 QUALITY ASSURANCE

- A. Furnish all equipment listed by and bearing the label of the UL or of an independent testing laboratory acceptable to the Engineer and the authority having jurisdiction.

1.07 DELIVERY, STORAGE, AND HANDLING

A. Shipping precautions:

1. After completion of shop assembly and successful Source Testing, pack all equipment, cabinets, panels, and consoles in protective crates and enclose in heavy duty polyethylene envelopes or secured sheeting to provide complete protection from damage, dust, and moisture.
2. Place dehumidifiers when required, inside the polyethylene coverings.
3. Skid-mount the equipment for final transport.
4. Provide lifting rings for moving without removing protective covering.
5. Display boxed weight on shipping tags together with instructions for unloading, transporting, storing, and handling at the job site.

B. Tagging:

1. Tag each component and/or instrument to identify its location, instrument tag number, and function in the system.
2. Firmly attach a permanent tag indelibly machine marked with the instrument tag number, as given in the tabulation, on each piece of equipment provided as part of this Section.
3. Tag instruments immediately upon receipt in the field.
4. Prominently display identification on the outside of the package.

1.08 PROJECT OR SITE CONDITIONS

- A. Provide instruments suitable for the installed site conditions including, but not limited to, material compatibility, site altitude, site seismic conditions, humidity, and process and ambient temperatures.

1.09 SEQUENCING (NOT USED)

1.10 SCHEDULING

- A. The supplier shall schedule a coordination meeting with the City and Engineer:
 - 1. The meeting shall take place during the design and control workshops.
 - 2. The supplier shall bring sample LOI graphic screens, including pop-up, trends, and alarm screens.
 - 3. Sample LOI graphic screens shall be reviewed and discussed.

1.11 WARRANTY

- A. As specified in Document 00701.

1.12 SYSTEM STARTUP (NOT USED)

1.13 CITY'S INSTRUCTIONS (NOT USED)

1.14 COMMISSIONING (NOT USED)

1.15 MAINTENANCE

- A. Provide the following spare PLC hardware for the PLC equipment in the MCPs and LCPs:
 - 1. 1 spare CPU for every type of CPU in the system.
 - 2. 2 spare I/O modules for every type of I/O module in the system.
 - 3. 2 spare power supplies for every power supply in the system.
 - 4. 1 spare network and/or communications card for every network or communications card in the system.
 - 5. 1 spare remote adaptor for every remote adaptor in the system.
 - 6. 1 spare backplane for every backplane size in the system.
- B. Provide 5 spare fuses of each type and rating furnished.

PART 2 PRODUCTS

2.01 GENERAL

- A. Signal transmission:
 - 1. Analog signals:
 - a. Furnish analog measurements and control signals that vary in direct linear proportion to the measured variable, unless otherwise indicated.
 - b. Furnish electrical analog signals outside control panels that are 4 to 20 mA 24 VDC, except as indicated.
 - c. Analog signals within enclosures may be 1 to 5 VDC.
 - d. Electrically or optically isolate all analog signals from other signals.
 - e. Discrete input signal: 24 VDC or 120 VAC according to the supplier's discretion.
 - f. Discrete output signals:
 - 1) Output type according to the supplier's discretion.
 - 2) Provide external terminal block mounted fuse with blown fuse indication for all discrete outputs.
 - 3) Interposing relays:
 - a) Provide interposing relays as required.

- g. Furnish regulated analog signals that are not affected by changes in supply voltage or load resistance within the unit's rating.
- h. Maintain the total 4 to 20 mA loop impedance to 10 percent below the published value at the loop operating voltage.
- i. Where necessary, reduce loop impedance by providing current-to-current (I/I) isolation amplifiers for signal re-transmission.

B. Discrete circuit configuration:

- 1. Configure discrete control circuits to fail safe, on loss of continuity or loss of power.
- 2. Alarm contacts: Fail to the alarm condition.
- 3. Control contacts fail to the inoperative condition unless otherwise indicated on the Drawings.

C. Grounding:

- 1. Provide control panels with a signal ground bus, isolated from the power ground bus:
 - a. Provide multiple panels in one location with a common point for signal ground bus connection to ground.
- 2. Single point ground shields and measurement loops at the source panel external terminals, unless otherwise noted, by bonding to the control panel signal ground bus.
- 3. Provide isolating amplifiers within control panels for field equipment possessing a grounded input or output, except when the panel circuit is galvanically isolated.

2.02 CONTROL PANEL

A. General:

- 1. PLC processor, power supply, I/O backplanes, and modules sized for connected I/O and required spares.
- 2. A LOI shall be provided on the face of the MCP enclosure for monitoring and control of the system. The MCP shall exercise control over all aspects of the system. Each unit shall be equipped with a control panel containing I/O modules and necessary interface with the MCP.
- 3. Ethernet communication equipment to provide communications with plant PCS system.
- 4. The MCP shall continuously monitor all operating parameters, and shall respond to alarms and emergency conditions by shutting down or activating system components. The MCP shall indicate alarm conditions locally at the LOI.
- 5. The MCP shall be capable of sending and receiving equipment status signals, analog data and alarms, and receiving both discrete and analog control signals from the plant PCS system via Ethernet.
- 6. The plant PCS system will be configured to store data for the system for reports and alarm generation. System manufacturer shall provide information on register addresses on all data, which are to be transmitted. The data register shall be contiguous for each data type.
- 7. Uninterruptible power supply.
- 8. All PLC and LOI programming required for fully functional package control system.

2.03 PROGRAMMABLE LOGIC CONTROLLERS (PLC) HARDWARE

- A. PLC hardware shall be:
 - 1. Siemens S7 no equals or substitutions. See Attachment No. 1 for parts list.
- B. General:
 - 1. Install all communications modules in the PLC backplane.
- C. Installed spare requirements:
 - 1. I/O points:
 - a. 20 percent spare capacity for each type of I/O signal at the MCP.
 - b. 20 percent spare capacity for each type of I/O signal at the local control panels.
 - c. Wire all spare I/O points to field terminal blocks in the corresponding panel.
 - d. Space shall be available in the MCP to support the future addition of 20 percent additional spare I/O.
 - 2. PLC backplane capacity:
 - a. At the MCP, 25 percent or 3 spare backplane slots, whichever is greater.
 - b. At the local control panels, 1 spare backplane slot.
 - 3. PLC memory:
 - a. 50 percent spare memory.

2.04 UNINTERRUPTIBLE POWER SUPPLY (UPS)

- A. General:
 - 1. Provide UPS at MCP.
 - 2. Provide UPS power at LCPs, either via UPS in the MCP, or via separate UPS mounted in each LCP.
 - 3. The minimum VA rating of the UPS shall be greater than or equal to 1.5 times the connected load or 700 VA, whichever is greater.
 - 4. The battery shall be sized to provide minimum 15 minutes runtime at full load.
 - 5. Provide calculations showing run time and VA loading of the UPS.
- B. UPS shall be one of the following:
 - 1. Free-standing UPS, 700-3,000 VA:
 - a. Emerson Network Power - Liebert GXT 2U (700 - 3000 VA).
 - b. Eaton Corporation - Powerware 9130 (700 - 3000 VA).
 - 2. Free-Standing UPS, above 3 kV:
 - a. Emerson Network Power - Liebert GXT2-6000RT208 (6 kVA).
 - b. Emerson Network Power - Liebert GXT2-10000RT208 (10 kVA).
 - c. Eaton Corporation - Powerware 9125 (5.0 and 6.0 kVA).
 - d. Eaton Corporation - Powerware 9155 (8 and 10 kVA).
- C. Provide manual maintenance bypass switch:
 - 1. 700 to 3,000 VA units: One of the following or equal:
 - a. Liebert Micropod 2U.
 - b. Powerware Powerpass 9125.
 - 2. Above 3,000 VA units: By manufacturer of UPS, with connections matched for operation with UPS.

2.05 HUMAN MACHINE INTERFACE (LOI) HARDWARE

- A. General:
 - 1. NEMA Type 4X rated.
 - 2. LOI shall communicate directly with PLC processor via dedicated communication cable.
 - 3. Provide color touch-screen type display.
- B. LOI shall be one of the following:
 - 1. Siemens.

2.06 PLC AND LOI PROGRAMMING

- A. General:
 - 1. The PLC programming software system shall be manufactured by the PLC hardware manufacturer.
 - 2. Provide one licensed copy of PLC programming software to the City.
 - 3. The LOI programming software system shall be manufactured by LOI hardware manufacturer.
 - 4. Provide one licensed copy of LOI programming software to the City.
- B. Coordination with plant control system:
 - 1. Coordinate with the City to determine the requirements for data transfer between the packaged system controls and the plant process control system.
 - 2. Supplier shall program MCP to aggregate the data into contiguous registers for efficient transfer to the plant process control system.
 - 3. Minimum data transfer shall be as indicated on the P&IDs and in the control strategies. Supplier shall supplement the I/O requirements with setpoints and virtual I/O required to implement the control strategies as specified in this Section.
 - 4. Unless otherwise stated, the packaged control system shall provide data to the plant control system with data in engineering units.
- C. General programming requirements:
 - 1. Use variable names or aliases derived from tag and loop identification on the P&IDs for all process values.
 - 2. Program slew rates for all setpoints to limit the effect of updated setpoints on the process:
 - a. Provide for control setpoints and manual speed and position selections.
 - b. Store new setpoints in one register, and gradually ramp the actual setpoint register at the slew rate until it reaches the new value.
 - c. Provide operator access to change slew rates through the controls system.
 - 3. Saved setpoints:
 - a. Provide an operator selection to save all setpoint values.
 - b. Provide an operator selection to restore all setpoints to the last saved value.
 - 4. Calculated values:
 - a. Program calculations such that division by zero errors cannot occur.

- b. Prevent calculations from generating values that exceed the limits of the equipment or data type structures (integers) internal to the PLC.
 - c. Configure counting functions (start counts and operation counts) to allow a minimum of 10,000 counts and to rollover to zero at an even decimal interval (1 followed by 4 or more zeros).
 - 5. Timers:
 - a. Provide programmable settling and proving timers in all control sequences for starting and stopping of equipment to allow the process to settle down before proceeding with any additional control functions.
 - 6. PLC status:
 - a. Furnish all information that depicts the status of all enclosures containing PLC or I/O in the control system, including but not limited to the following:
 - 1) PLC cabinet over-temperatures from high temperature switch.
 - 2) Intrusion status on all enclosures equipped with intrusion switches.
 - 3) AC power failure.
 - 4) DC power supply failure.
 - 5) UPS failure signal.
 - 7. PLC system communication status:
 - a. Furnish a minimum of 1 screen to display all communication errors and status within the control system network:
 - 1) Communication between PCS and PLC.
 - 2) PLC to RIO.
 - 3) Display status of each node, and summary of failures over the past 60 minutes.
 - b. Generate a communications alarm if any communication fault is detected.
 - c. In the event of communications loss:
 - 1) Continue normal operation at each PLC with last known shared values.
- D. Common control functions:
 - 1. Incorporate common control functions into all control loops and devices and into the control programming, whether or not specifically specified in the specific control descriptions or elsewhere in the Contract Documents.
 - 2. Alarms:
 - a. Generate alarms within the PLC logic.
 - b. Indicate alarms at PCS and the LOI. Enable acknowledgement from the LOI.
 - c. Once the alarm is acknowledged by an operator, display alarm conditions in a steady state (not flashing) while the alarm condition is still present:
 - 1) Use interlocks and proving timers to prevent alarms from operating due to power loss, except for loss of power alarms.
 - 3. Where run time accumulation is required, integrate accumulated run time to the nearest 0.1 hours whenever the running status input indicates that the equipment is running:
 - a. Display total run time in hours.
 - 4. For all monitored analog values:
 - a. Maintain trends in PCS.
 - b. Totalize flows:
 - 1) Display totals on the HMI and LOI.

5. Analog data processing:
 - a. Engineering units conversion:
 - 1) Use engineering units for all analog point values. Convert analog inputs to engineering units.
 - b. Analog magnitude checking:
 - 1) Provide clamps to prevent operator-entered values (setpoints, etc.) that fall outside acceptable limits.
6. I/O filtering and processing:
 - a. Analog input filtering:
 - 1) Provide RTU programming for each analog input to implement an adjustable first order filter, for the purpose of smoothing out spikes and other noise for analog transmitter input signals. By default, shall configure analog inputs with no filtering affect.
 - 2) Monitor analog input signal quality:
 - a) Over range: The input value is above the normal range (typically over 21 mA).
 - b) Under range: The input value is below the normal range (typically under 3 mA, indicating a probable broken connection).
 - c) Generate alarms for over or under range inputs.
 - d) Do not use over- or under-range values for control or calculation purposes:
 - (1) Where a second instrument is provided to monitor the same condition (a redundant instrument, or additional instruments furnished for averaging or different operating modes), and has a valid signal, use that input for control.
 - (2) Otherwise, hold all outputs affected by the signal at their last values before the signal went out of range.
 - 3) Digital input filtering (proving timer):
 - a) Provide an adjustable time delay function (0-10 seconds) on discrete input for the purpose of de-bouncing. By default, discrete inputs shall be configured with de-bounce timers set to zero seconds.
7. LOI/HMI HAND-OFF-AUTO:
 - a. Where indicated, provide HAND-OFF-AUTO and START-STOP selections accessed from an LOI or HMI for operators with sufficient security, to provide the following operating modes:
 - 1) AUTO: The normal, Automatic control mode of the strategy which allows full PLC control in response to process conditions and programmed sequences.
 - 2) HAND: Enables Manual control where control decisions are made by an operator through the START-STOP, OPEN/CLOSE, or other selections as indicated.
 - 3) OFF: Automated control is disabled and PLC calls for all associated equipment to stop and valves to close or go to their identified safe state.
8. Display the current status of all operator selections (HAND/AUTO, START/STOP, etc.) on the LOI.
9. Motor control:
 - a. Display current REMOTE status on the screens.
 - b. Monitor the device's running status:
 - 1) Display the current status (running or stopped) on the screens.

2.07 PANELS, ENCLOSURES, AND PANEL COMPONENTS

- A. General:
 - 1. Provide instruments and other components performing similar functions of the same type, model, or class, and from one manufacturer.
 - 2. It shall be the responsibility of the supplier to design and size all panels.
 - 3. Design panels to fit in the space as indicated on the Drawings.

- B. Requirements:
 - 1. Each panel will be fed by a 120-volt single-phase AC panel power circuit with a dedicated utility circuit. Panel designs shall include control power transformers, power supplies and distribution components required to derive all necessary control voltages.
 - 2. Unless otherwise indicated on the Drawings, instruments provided as part of the packaged system shall be powered from supplier provided control cabinets.

- C. Panels/enclosures:
 - 1. Manufacturers: One of the following:
 - a. Rittal.
 - b. Hoffman Engineering.
 - c. Saginaw Control & Engineering.
 - 2. Panel assembly:
 - a. General guidelines for panel fabrication include:
 - 1) Continuous welds ground smooth.
 - 2) Exposed surfaces free of burrs and sharp edges.
 - 3) Base formed of heavy channel iron, either galvanized or powder coated, minimum 1/2-inch holes at 12-inch spacing to accommodate anchoring of freestanding enclosures to floor.
 - b. Provide stiffeners for back mounting panels in enclosures larger than 4 feet. In addition, secure the panels in place by collar studs welded to the enclosure.
 - 3. In addition to the requirements specified above, the following requirements for NEMA Type 4X stainless steel enclosures apply:
 - a. Minimum 14 gauge, Type 304 stainless steel.
 - b. Captive stainless steel cover screws threaded into sealed wells.
 - c. Finish: Unpainted, brushed finish.
 - d. Specifically designed for use with flange-mounted disconnect handles where required or as indicated on the Drawings.
 - 4. General wiring requirements:
 - a. Wiring methods: Wiring methods and materials for panels shall be in accordance with the NEC requirements for general purpose (no open wiring) unless otherwise specified.
 - b. Install all components in accordance with the manufacturer's instructions included in the listing and labeling.
 - c. Where the electrical power supply voltage to the control panel is more than 120 VAC, provide the panel with a control power transformer and flange mounted disconnect:
 - 1) Mechanically interlock the disconnect switch with the control enclosure doors so that no door can be opened unless the power is disconnected. Reactivate power once all doors are closed.

- 2) Disconnect shall remove power from all power and control circuits, except for externally wetted signal and control signals. Externally powered circuits shall be grouped together, labeled, and provided with finger safe barriers.
 - d. Control panels supplied with 120 VAC:
 - 1) Provide an internal breaker with the line side terminals covered by a barrier.
 - 2) Provide a nameplate prominently positioned on the control panel identifying the location of the power source and a warning statement requiring the source to be disconnected before opening the door to the enclosure.
 - e. Provide a nameplate on the cover of the control panel identifying all sources of power supply and foreign voltages within the control panel.
 - f. Provide transformers, protective devices and power supplies required to convert the supply voltage to the needed utilization voltage.
 - g. Provide surge protection device on input supply power.
 - h. Provide nonmetallic ducts for routing and organization of conductors and cables:
 - 1) Provide separate ducts for signal and low voltage wiring from power and 120 VAC control wiring.
 - i. Provide 1/2-A fuse for each 4-20 mA circuit.
 - j. Provide 5-A fuse for each discrete input loop.
 - k. Conductors and cables shall be run from terminal to terminal without splice or joints. Exceptions:
 - 1) Factory applied connectors molded onto cables shall be permitted. Such connectors shall not be considered as splices or joints.
 - l. The control panel shall be the source of power for all 120 VAC devices interconnected with the control panel including, but not limited to:
 - 1) Solenoid valves.
 - 2) Instruments mounted both in the control panel and remotely connected to the control panel.
- D. Thermal management:
- 1. Provide heating, cooling, and dehumidifying devices in order to maintain all instrumentation and control devices to within an acceptable range.
 - 2. Provide enclosure temperature sensor:
 - a. Manufacturer: One of the following:
 - 1) Omega, EWS Series.
 - 2) TCS Basys Controls, TS Series.
- E. Pilot devices:
- 1. General:
 - a. Provide operator pushbuttons, switches, and pilot lights, from a single manufacturer.
 - b. Size:
 - 1) 30.5 millimeters.
 - c. Heavy duty.
 - d. Pushbuttons:
 - 1) Contacts rated:
 - a) NEMA Type A600.
 - 2) Furnish 1 spare normally open and normally closed contact with each switch.

- e. Selector switches:
 - 1) Contacts rated:
 - a) NEMA Type A600.
 - b) Knob type.
 - 2) Furnish 1 spare normally open contact and normally closed contact with each switch.
 - 3) Provisions for locking in the OFF position where lockout provisions are indicated on the Drawings.
 - f. Pilot lights:
 - 1) Type:
 - a) LED.
 - 2) Push to test.
2. Indoor and outdoor areas:
- a. NEMA Type 4/13.
 - b. Manufacturer: One of the following or equal:
 - 1) Allen-Bradley Type 800T.
 - 2) Square D Class 9001 Type K.
 - 3) General Electric Type CR104P.
 - 4) IDEC TWTD.
- F. Relays:
- 1. General:
 - a. For all types of 120 VAC relays, provide transient surge protection across the coil of each relay.
 - b. For all types of 24 VDC relays, provide a free-wheeling diode across the coil of each relay.
 - 2. General purpose:
 - a. NEMA A300 rated for standard relays and NEMA B300 for latching.
 - b. Plug-in type.
 - c. LED indication for relay energized.
 - d. Touch safe design: All connection terminals to be protected against accidental touch.
 - e. Provide additional (slave/interposing) relays when the following occurs:
 - 1) The number or type of contacts shown exceeds the contact capacity of the specified relays.
 - 2) Higher contact rating is required in order to interface with starter circuits or other equipment.
 - f. DIN rail mounting on 35-mm rail.
 - g. Ice Cube type relays shall be provided with retainer clips to secure relay in socket.
 - h. Manufacturer: One of the following:
 - 1) Phoenix Contact PLC series.
 - 2) Potter and Brumfield Type KRP or KUP.
 - 3) IDEC R* series. (* = H, J, R, S, U).
 - 4) Allen-Bradley Type 700 H Series.
 - 5) Schneider Electric/Square D Type K.
 - 3. Time delay:
 - a. Provide time delay relays to control contact transition time.
 - b. NEMA A300 rated.
 - c. Minimum timing range: 0.1 seconds to 10 minutes.

- d. Manufacturer: One of the following:
 - 1) Agastat Type Series 7000.
 - 2) Allen-Bradley Type 700HR.

G. Terminal blocks:

- 1. Din rail mounting on 35-mm rail.
- 2. Suitable for specified AWG wire.
- 3. Rated for 30 amperes at 600 volts.
- 4. Screw terminal type.
- 5. Finger safe protection for all terminals for conductors.
- 6. Construction: Polyamide insulation material capable of withstanding temperature extremes from - 40 degrees Celsius to 105 degrees Celsius.
- 7. Terminals: Plainly identified to correspond with markings on the diagrams:
 - a. Permanent machine printed terminal identification.
- 8. Identify terminals suitable for use with more than 1 conductor.
- 9. Provide minimum 10 percent spare terminals.
- 10. Manufacturer: One of the following:
 - a. Phoenix Contact UK5 Series.
 - b. Entrelec M4/6.
 - c. Allen-Bradley Series 1492.
- 11. Fuses (holders) and circuit breakers:
 - a. Fuse holders:
 - 1) Modular type:
 - a) DIN rail mounting on 35-mm rail.
 - b) Touch safe design: All connection terminals to be protected against accidental touch.
 - c) Incorporates blown fuse indicator.
 - d) UL 489 rated, as applicable.
 - 2) Provide nameplate identifying each fuse:
 - a) As specified in Section 16075.
 - 3) Manufacturer: One of the following:
 - a) Phoenix Contact.
 - b) Entrelec.
 - c) Allen-Bradley 1492-FB Series B.

H. Transient/surge protection devices:

- 1. Provide surge protection device (SPD) for power entrances:
 - a. Nominal 120 VAC with a nominal clamping voltage of 200 volts.
 - b. Non-faulting and non-interrupting design.
 - c. A response time of not more than 5 nanoseconds.
- 2. Control panel power system level protection, non-UPS powered:
 - a. Design to withstand a maximum 10 kA test current of an 8/20 μ s waveform according to IEEE C62.41.1-2002 Category C Area.
 - b. Provide both normal mode noise protection (between current carrying conductors) and common mode (between current carrying conductor and neutral) surge protection.
 - c. DIN rail mounting.
 - d. Visual status indication of MOV status on the input and output circuits.
 - e. Meeting the following requirements:
 - 1) Response time: Less than or equal to 100 ns.
 - 2) Attenuation: Greater than or equal to - 40 dB at 100 kHz as determined by a standard 50 ohms insertion test.

- 3) Safety approvals:
 - a) UL 1283 (EMI/RFI Filter).
 - b) UL 1449 2nd Edition.
 - f. Manufacturer: One of the following:
 - 1) Phoenix Contact type SFP TVSS/Filter.
 - 2) Liebert Accuvar Series.
 - 3) Islatrol.
 - 3. Data and signal line protectors – panel mounted:
 - a. Surge protection minimum requirements: Withstand a 10 kA test current of an 8/20 μ s waveform in accordance with IEEE C62.41.1-2002 Category C Area.
 - b. DIN rail mounting on 35-mm rail (except field mounted SPDs).
 - c. SPDs consisting of 2 parts:
 - 1) A base terminal block.
 - 2) A plug protection module:
 - a) Replacing a plug does not require the removal of any wires nor interrupt the signal.
 - b) Base and plug coded to accept only the correct voltage plug.
 - d. SPD manufacturer: One of the following:
 - 1) Phoenix Contact Plugtrab Series.
 - 2) Joslyn JMD Series.
 - 4. Data and signal line protectors – field mounted:
 - a. Surge protection minimum requirements: Withstand a minimum 10 kA test current of an 8/20 μ s waveform in accordance with IEEE C62.41.1-2002 Category C Area.
 - b. Manufacturer: One of the following:
 - 1) Phoenix Contact Pipetrab.
 - 2) Boxtrab.
 - 3) Joslyn JMD Series.
- I. Power supplies:
 - 1. Design power supply systems so that either the primary or backup supply can be removed, repaired, and returned to service without disrupting the system operation.
 - 2. Convert 120 VAC to 24 volt DC or other DC voltages required.
 - 3. Provide power supplies configured as fully redundant units consisting of 2 power supplies connected with an automatic switchover unit with alarm contacts monitored by the PLC.
 - 4. Sized to provide 40 percent excess rated capacity.
 - 5. UL 508C listed to allow full rated output without de-rating.
 - 6. Provide fuse or short-circuit protection.
 - 7. Provide a minimum of 1 set of dry contacts configured to change state on failure for monitoring and signaling purposes.
 - 8. Output regulation: Within 0.05 percent for a 10 percent line change or a 50 percent load change:
 - a. With remote voltage sensing.
 - 9. Operating temperature range: 0 degrees Celsius to 50 degrees Celsius.
 - 10. Touch safe design: All connection terminals to be protected against accidental touch.

11. Manufacturer: One of the following:
 - a. Phoenix Contact Quint series.
 - b. IDEC PS5R series.
 - c. Sola.
 - d. Acopian.

- J. Limit switches:
 1. NEMA 4X.
 2. AC contact rating 120 V, 10 A.
 3. DC contact rating 125 V, 0.4 A.
 4. DeviceNet compatible as indicated in the Drawings.
 5. Provide robust actuation mechanism not prone to degradation.
 6. Provide complete actuator mechanism with all required hardware.
 7. Allows for contact opening even during contact weld condition.
 8. UL approved.
 9. Operating temperature range: -18 degrees to +110 degrees Celsius (0 degrees to 230 degrees Fahrenheit).
 10. Manufacturer:
 - a. Allen-Bradley 802.
 - b. Eaton E47, E49, E50.
 - c. ABB equal.

- K. Provide a folding shelf for enclosures that contain programmable controllers. The shelf shall be mounted on the inside surface of the door, capable of supporting a laptop computer.

- L. Protection:
 1. Provide disconnecting, short-circuit, and overcurrent protection for all control panels.
 2. Provide a separate protective device for each 120 VAC powered electrical device:
 - a. Each 120 VAC control loop and instrument shall have an individual circuit breaker within its respective control panel and clearly identified for function.
 - b. Each 120 VAC and 24 VDC PLC output shall have its own individual fuse external of the I/O card with blown fuse indication:
 - 1) Size external fuse to open before any I/O card mounted fuses.
 3. Provide dedicated single-pole circuit breakers, one for the panel luminaire(s), and one for the panel receptacle(s):
 - a. 15 amperes, 120 VAC.

- M. Conductors and cables:
 1. Power and control wiring:
 - a. Materials: Stranded, soft annealed copper.
 - b. Insulation: 600 V Type MTW.
 - c. Minimum sizes:
 - 1) Primary power distribution: 12 AWG.
 - 2) Secondary power distribution: 14 AWG.
 - 3) Control: 16 AWG.
 - d. Color:
 - 1) AC power (line and load): BLACK.
 - 2) AC power (neutral): WHITE.

- 3) AC control: RED.
 - 4) DC power and control: BLUE.
 - 5) Foreign voltages: YELLOW.
 - 6) Ground: GREEN.
2. Signal cables:
- a. Materials: Stranded, soft annealed copper.
 - b. Insulation: 600 V, PVC outer jacket, 16 AWG paired triad overall aluminum shield (tape), with copper drain wire.
 - c. Color:
 - 1) 2 conductor:
 - a) Positive (+): BLACK.
 - b) Negative (-): WHITE or RED.
 - 2) 3 Conductor:
 - a) Positive (+): BLACK.
 - b) Negative (-): RED.
 - c) Signal: WHITE.
 - d. Insulate the foil shielding and exposed drain wire for each signal cable with heat shrink tubing.
- N. Receptacles:
1. Provide one duplex receptacle located every 4 feet of enclosure width, spaced evenly along the back mounting panels.
 2. GFCI, 125-volt, single-phase, 15-ampere.
- O. Grounding:
1. Provide the following:
 - a. Grounding strap between enclosure doors and the enclosure.
 - b. Equipment grounding conductor terminals.
 - c. Bond multi-section panels together with an equipment grounding conductor or an equivalent grounding bus.
 2. Design so that removing a device does not interrupt the continuity of the equipment grounding circuit.
 3. Provide an equipment-grounding terminal for each incoming power circuit, in the vicinity of the phase conductor terminal.
 4. Size ground wires in accordance with NEC and UL Standards, unless noted otherwise.
 5. Connect the door stud on the enclosures to an equipment-grounding terminal within the enclosure using an equipment-bonding jumper.
 6. Bond together all PLC (remote or local) processor racks, and conductive enclosures of power supplies and connect to the equipment grounding circuit.

2.08 FIELD INSTRUMENTS

- A. General:
1. Instrument housing shall be rated NEMA Type 4 or 4X.
 2. Wetted materials shall be compatible with process fluid and manufacturer's recommendations for the intended service.
 3. For analog field instruments, provide local LCD display.
 4. Provide sunshades for all transmitters located outdoors.
 5. Provide all hardware for instrument mounting.
 6. Factory calibrate each instrument at a facility that is traceable to the NIST.

- B. Ultrasonic Point Sensor Ultrasonic point sensor with 120/230VAC supply and at least 2 Form-C dry contacts as outputs to monitor high and low effluent level.
 - 1. Water Level Sensor - Point:
 - a. One of the following or equal:
 - 1) Endress+Hauser
 - 2) Siemens Pointek

- C. UV transmittance monitors:
 - 1. Manufacturer's, one of the following or equal:
 - a. YSI.
 - b. HACH
 - 2. General:
 - a. UV transmittance meter systems shall measure the UV transmittance of wastewater.
 - b. Continuous monitoring of UV transmittance independent of UV intensity sensor.
 - c. Integrated in channel or tank with the radiation source immersed in water.
 - d. Lamp and sensor quartz sleeve shall have an automatic cleaning mechanism.
 - e. Measurement of UV transmittance to specify water quality.
 - 3. Performance requirements:
 - a. 3 percent full scale accuracy.
 - 4. Element:
 - a. UV radiation source:
 - 1) Mercury lamp.
 - b. UV sensors:
 - c. Calibrated selectivity greater than 99 percent at 254 nanometer. Non-aging, temperature stability up to 70 degrees Celsius for continuous operation.
 - d. UV transmission (1 centimeters) measurement range: 5 to 100 percent.
 - e. No battery backup required.
 - f. NEMA Type 4X/IP 65 weatherproof corrosion resistant enclosure.
 - g. Neither pump nor pipe work required.
 - h. Direct in-channel measurement without the need of a filter.
 - i. Stainless steel quartz tube protector.
 - 5. Transmitter:
 - a. NEMA Type 4X/IP65 thermoplastic cabinet with instrumentation window.
 - b. Wall mounting.
 - c. Display of UV transmission (percent).
 - d. RS-232 serial interface.
 - e. Analog output, selectable 0 to 20 milliamperes (mA) or 4 to 20 mA.
 - f. Maximum distance to junction box: 25 feet.
 - 1) Power supply:
 - a) 120 VAC.
 - 2) Outputs:
 - a) Isolated 4 to 20 mA DC.

2.09 ACCESSORIES (NOT USED)

2.10 CONTROL SYSTEM SOURCE TEST

- A. Source Test - General:
1. Right of observation: The City retains the right to observe all Source test activities including any and all subsystem preparation, pretests, troubleshooting, retests, warm-up, and software modification and/or update.
 2. The City reserves the right to test any specified function, whether or not explicitly stated in the test submittal.
 3. Costs for repeating testing: The supplier shall pay for Engineer's and other City's representatives' travel, subsistence for witnessing the repetition of failed tests.
 4. Correction of deficiencies: Any deficiencies observed during the test shall be corrected and retested before completion of the test.
 5. Any changes and/or corrections shall be noted on the test forms. Engineer shall witness the revisions and/or corrections prior to leaving the test site.
 6. If the corrections and/or revisions are too extensive to be made while the Engineer is scheduled to be at the Source test site, the Source Test shall be, at the Engineer's sole discretion, considered failed, and the test shall be restarted at a later date. All costs for the re-test shall be borne by the supplier.
- B. Testing simulation:
1. The Source shall make use of hardware simulators that contain switches, pilot lights, variable analog signal generators, and analog signal level displays, which shall be connected to the I/O points of the PLCs and controllers provided. All inputs and outputs shall be simulated and proper control and system operation shall be validated.
- C. Panel inspections:
1. The Engineer to inspect each control panel for completeness, workmanship, fit and finish, and compliance with the Contract Documents and the approved shop drawings.
 2. Inspection to include, as a minimum: Layout, mounting, wire and data cable routing, wire tags, power supply, components and wiring, I/O components layout (including terminals, wiring and relays), device layout on doors and front panels, and proper ventilation operation.
- D. I/O test:
1. Verify that I/O is properly wired to field terminals and is properly mapped into the PLC and operator displays.
 2. Test forms to include, but not be limited to:
 - a. PLC and panel number.
 - b. I/O type.
 - c. I/O tag name.
 - d. Panel terminal block numbers.
 - e. Rack/slot/number of I/O point.
 - f. Check-off for correct response for each I/O point.
 - g. Space for comments.
 - h. Initials of individual performing test.
 - i. Date test was performed.
 - j. Witness' signature lines.

- E. Control logic test:
1. The purpose of this test is to verify that all software functions and logic work as specified, along with any hardwired logic or functions in the tested control panels.
 2. Testing requirements:
 - a. Demonstrate each function described in the general and specific control description. Demonstrate in detail how each function operates under a variety of operating scenarios. Test to verify the application of each general control strategy function to each specific control strategy or loop description.
 - b. Demonstrate the proper operation of the programming and configuration for each control strategy or loop description. Test each strategy or loop description on a sentence-by-sentence and function-by-function basis. Loops with similar or identical logic must each be tested individually.
 3. Test forms:
 - a. Include the fully revised and approved for the loop being tested.
 - b. Identify the cause and effect as each I/O point is toggled through the simulator. Check boxes shall be provided to track proper and/or improper operation of the loop.
 - c. Any deficiencies or operational changes shall be noted on the forms for correction and documentation.
 - d. Include signature and date lines.

PART 3 EXECUTION

3.01 EXAMINATION (NOT USED)

3.02 PREPARATION (NOT USED)

3.03 INSTALLATION

- A. Field instruments installation:
1. Install field instruments as specified in the Contract Documents and in accordance with API 550 and 551 and the manufacturer's instructions.
 2. Mount field instruments so that they can be easily read, readily approached, and easily serviced, and so they do not restrict access to mechanical equipment:
 - a. Mount field instruments on a pipe stand or local panel, if they are not directly mounted.
 3. Make connections from rigid conduit systems to field instruments with PVC coated flexible conduit:
 - a. Type of flexible conduit required for the area classification.
 - b. Maximum length of 18 inches.
 4. Connect field instruments with cable as specified in the Electrical Specifications, except when the manufacturer requires the use of special cable, or otherwise specified in this Section:
 - a. Special cable applications shall be in accordance with the NEC.
 5. Verify the correctness of each installation:
 - a. Polarity of electric power and signal connections.
 - b. Ensure all process connections are free of leaks.

- B. Process sensing lines and air tubing:
 - 1. Install individual tubes parallel and/or perpendicular to and near the surfaces from which they are supported.
 - 2. Provide supports for rigid tubing at intervals of not more than 3 feet.
 - 3. Slope horizontal runs of instrument tubing at a minimum of 1/16th-inch per foot to allow for draining of any condensate.
 - 4. Bends:
 - a. Use proper tool.
 - b. Make bends for parallel lines symmetrical.
 - c. Make bends without deforming or thinning the walls of the tubing.
 - 5. Square-cut and clean all ends of tubing before being inserted in the fittings.
 - 6. Provide bulkhead fittings at all panels requiring pipe and/or tubing entries.
 - 7. Use stainless steel tubing for all piping hard piped from the air header, unless otherwise indicated on the Drawings or not compatible with the fluids or atmosphere in the area:
 - a. Use flexible connections only on moving equipment and under the constraint that the length shall be less than 1.5 times maximum travel of the equipment.
- C. Instrument tagging:
 - 1. Provide all field-mounted instruments with nameplates:
 - a. Nameplates engraved with the instrument's full tag number as indicated on the Drawings:
 - 1) Affix tags with stainless steel wire fasteners.
 - 2. Provide all back of panel instruments with nameplates:
 - a. Engraved with the instrument's full tag number.
 - 3. Provide all front of panel instruments with a nameplate:
 - a. Engraving to include the following:
 - 1) Instrument's full tag number.
 - 2) Service description.
 - b. Nameplates:
 - 1) Secure nameplates to the panel with stainless steel screws.
 - 2) Use an approved adhesive if screws would violate the NEMA or other ratings of the enclosure.
- D. Cable and conductor termination:
 - 1. Terminate all cables and conductors on terminal blocks.
 - 2. Terminal block enclosures:
 - a. Suitable for the area classification.
- E. Surge protection:
 - 1. Provide outdoor field instrument loops with voltage surge protection units installed on the instruments.
 - 2. Individually fuse each 4-20 mA DC loop with a 1/16 ampere fuse between power supplies and receiver surge protectors.
 - 3. Provide voltage surge protection for 4-wire transmitters and analyzers:
 - a. Protect both power source and signal loop.

3.04 ERECTION, INSTALLATION, APPLICATION, CONSTRUCTION (NOT USED)

3.05 REPAIR/RESTORATION (NOT USED)

3.06 RE-INSTALLATION (NOT USED)

3.07 FIELD QUALITY CONTROL

A. General:

1. Failure testing:
 - a. In addition to demonstrating correct operation of all specified features, demonstrate how the system reacts and recovers from abnormal conditions including, but not limited to:
 - 1) Equipment failure.
 - 2) Operator error.
 - 3) Communications sub-system error.
 - 4) Power failure.
 - 5) Process equipment failure.
 - 6) High system loading conditions.

B. Loop check/validation:

1. Check all control loops under simulated operating conditions.
2. Provide "end-to-end" tests:
 - a. Test PLC/controller inputs and outputs from field device to all operator displays and pilot devices.

C. Pre-commissioning (functional) test:

1. General:
 - a. Commence pre-commissioning tests after completion of all loop check/validation tests:
 - 1) Pre-commissioning to demonstrate proper operation of all systems with process equipment operating over full operating ranges under conditions as closely resembling actual operating conditions as possible.
2. Control logic operational validation:
 - a. The purpose of control logic validation is to field test the operation of the complete control system, including all parts of the system, all control panels (including vendor control panels), all control circuits, all control stations, all monitored/controlled equipment, and final control elements.
3. Loop tuning:
 - a. Optimally tune all electronic control stations and software control logic incorporating proportional, integral, or derivative control. Apply control signal disturbances at various process variable levels and adjusting the gain, reset, or rate settings as required to achieve proper response.
4. Pre-commissioning validation sheets:
 - a. Document each pre-commissioning test on an approved test form.
 - b. Document loop tuning with a report for each loop, including two-pen chart recordings showing the responses to step disturbance at a minimum of 3 setpoints or process rates approved by the Engineer. Show tuning parameters on the charts, along with time, date, and sign-off by supplier and Engineer.

5. Pre-commissioning certification:
 - a. Document via a certified report the completion of all pre-commissioning and test activities:
 - 1) Including all test forms with test data entered, submitted to the Engineer with a clear and unequivocal statement that all pre-commissioning test requirements have been satisfied.
- D. Performance/reliability/operational tests:
 1. After successful completion of the pre-commissioning test as accepted by the Engineer and City, the performance test can proceed.
- E. The performance test may be performed concurrently with the 7-day operational test specified in Section 01756.

3.08 CLEANING

- A. Vacuum clean all control panels and enclosures before start-up and again after final completion of the project.
- B. Clean all panel surfaces.
- C. Return to new condition any scratches and/or defects.
- D. Wipe all instrument faces and enclosures clean.
- E. Leave wiring in panels in a neat, clean, and organized manner.

3.09 DEMONSTRATION AND TRAINING

- A. Training:
 1. Provide system maintenance and operator training courses for all the instrumentation, control systems furnished.
 2. Training course requirements:
 - a. Operator training:
 - 1) Operator's training shall include:
 - a) Control system overview: Architecture, equipment functions, software components, etc.
 - b) Display navigation, overview, and types of displays.
 - c) Process and equipment monitoring and control: Basic principles and operation.
 - d) Logging ON and OFF the system and description of the security and access system.
 - e) Alarm subsystem.
 - f) Trending: Provide a thorough session on how to use all trending functions.
 - b. PLC hardware training:
 - 1) Furnish training on PLC hardware and on related components, including battery backup equipment, UPSs, LOI hardware, control circuits, and analog circuits.
 - 2) Furnish training on PLC hardware principles, product features, proper installation, operation, troubleshooting, and maintenance.
 - 3) PLC training may be provided by manufacturer's certified trainers.

- c. PLC software training:
 - 1) Furnish training on PLC software:
 - a) Training covers the programming conventions, new standardized software modules, specific control strategy programs, and documentation created for the work performed under this Contract.
- d. LOI hardware and software training:
 - 1) Provide the following:
 - a) Overview of hardware and firmware, including starting, stopping, and PLC interface.
 - b) Configuration of tag database.
 - c) Creating, editing, and saving display screens.
 - d) Troubleshooting.
- e. Instrumentation training:
 - 1) Furnish training covering all instruments and control panels.
 - 2) Train maintenance staff in the use, cleaning, calibration, maintenance, and troubleshooting of all the instruments furnished within this project.
 - 3) Furnish training on the operation of new hardwired controls.

3.10 SCHEDULES

- A. The provided information does not necessarily include all required instruments. Furnish all instruments identified on the Contract Drawings or in the Contract Specifications. If an instrument is shown on one of these documents, it shall be considered to be shown on all.
- B. Produce completed Instrument data sheets for all instruments required under this Contract:
 - 1. Submit all instrument data sheets for review.
 - 2. Furnish instrument data sheets in both hard copy and electronic format.
- C. The P&IDs are intended as a guideline for the supply of instruments. Some information needed to order and specify the required instruments is not included.

SECTION 17055 - ATTACHMENT A - SIEMENS PLC PARTS LIST

1. HMI Panel 6AV2124-0QC02-0AX0	SIMATIC HMI TP1500 COMFORT
2. PLC CPU 6ES7516-3AN01-0AB0	CPU 1516-3 PN/DP, 1MB PROG., 5MB DATA
3. Extended IO Enterface Module 6ES7155-5AA00-0AC0	SIMATIC ET 200MP IM 155-5 PN HF
4. Power Supply 6ES7507-0RA00-0AB0	SIMATIC S7-1500, SYSTEM POWER SUPPLY
5. Input Module 6ES7521-1FH00-0AA0	DI 16X230VAC BA 120-230vAC
<i>****Note: Any relay or contact points going to the input module MUST have a Minimum wetting current of 5mA.</i>	
6. Relay Output 6ES7522-5HH00-0AB0	DIG. OP MODULE, S7-1500, DQ16X230VAC
<i>****Note: All outputs must be isolated with Interposing Relays regardless of load current rating.</i>	
7. Analog Input 6ES7531-7KF00-0AB0	AI 8XU/I/RTD/TC ST
8. Analog Output 6ES7532-5HF00-0AB0	AQ 8XU/I HS
9. RS422/485 6ES7540-1AB00-0AA0	CM PTP RS422/485 BA
10. Mounting Rail 6ES7590-1AB60-0AA0	MOUNTING RAIL 160MM (6.3")
11. Mounting Rail 6ES7590-1AC40-0AA0	SIMATIC S7-1500, MOUNTING RAIL 245 MM (APPR. 9.6 INCH); INCL. GROUNDING ELEMENT, INTEGRATED DIN RAIL FOR MOUNTING OF SMALL COMPONENTS SUCH AS CLAMPS,

END OF SECTION

PROPOSAL FORMS

FOR

LAGUNA TREATMENT PLANT ULTRAVIOLET (UV) LIGHT DISINFECTION EQUIPMENT SYSTEM

REQUEST FOR PROPOSALS 16-71

September 2016

UPDATED PRICE REQUEST

DECEMBER 2019



DOCUMENT 00410

PROPOSAL FORM

UPDATED PRICE REQUEST

DECEMBER 2019

PROJECT IDENTIFICATION:

**City of Santa Rosa
Ultraviolet (UV) Light Disinfection Equipment System
Proposal Number 16-71**

THIS PROPOSAL IS SUBMITTED BY:

Calgon Carbon UV Technologies LLC

(Supplier)

3000 GSK Drive, Moon Township, PA 15108

(Supplier Address)

THIS PROPOSAL IS SUBMITTED TO:

BRANDALYN TRAMEL

PURCHASING AGENT

CITY OF SANTA ROSA PURCHASING OFFICE

635 FIRST ST., 2ND FLOOR

SANTA ROSA, CA 95404

707-543-3706 VOICE

Btramel@srcity.org

- 1.01 The undersigned Supplier proposes and agrees, if this Proposal is accepted, to enter into a Memorandum of Understanding with CITY in the form included in the Procurement Documents to perform and furnish all Goods and Services as specified or indicated in the Procurement Documents within the specified time and for the amount indicated in this Bid and in accordance with the other terms and conditions of the Procurement Documents.

ARTICLE 2 - SUPPLIER'S ACKNOWLEDGMENT

- 2.01 Supplier accepts all of the terms and conditions of the RFP. Supplier will execute and submit the Memorandum of Understanding and other attachments as required by the Procurement Documents and as provided in CITY's Notice of Selection, which MOU will set pricing for a period of not less than eighteen months following approval of the MOU by the CITY's Board of Public Utilities.

ARTICLE 3 - SUPPLIER'S REPRESENTATIONS

- 3.01 In submitting this Bid, the Supplier represents that:
 - A. Supplier has examined copies of all the Procurement Documents and of the following Addenda (receipt of all which is hereby acknowledged):

ADDENDA

No.	<u>No. 1</u>	Dated	<u>October 10, 2016</u>
No.	_____	Dated	_____
No.	_____	Dated	_____
No.	_____	Dated	_____
No.	_____	Dated	_____

- B. Supplier is familiar with and has satisfied itself as to all federal, state, and local laws and regulations that may affect cost, progress, performance, and furnishing of the equipment and the Work described herein including but not limited to the requirements in the Technical Specifications and Title 22 of the California Code of Regulations.
- C. Supplier has given CITY written notice of all conflicts, errors, ambiguities, or discrepancies that Supplier has discovered in the Procurement Documents and the written resolution thereof by the CITY is acceptable to Supplier, and the Procurement Documents are generally sufficient to indicate and convey understanding of all terms and conditions for performing and furnishing the equipment and the Work identified on the Proposal.

ARTICLE 4 - BASIS OF PROPOSAL

- 4.01 Furnish the CITY with a complete UV Disinfection Systems per the attached general specifications, technical specifications and plans, and requirements. Indicate the make and model you are quoting and attach descriptive literature.

CITY OF SANTA ROSA, LAGUNA TREATMENT PLANT (LTP) PROPOSAL FORM		
Item No.	Description	Proposal Price (\$ US)
Equipment Costs		
1	UV Disinfection System, as specified in the Technical Specifications (sales and use taxes not included)	\$
2	Spare parts and special tools, as specified in the Technical Specifications	\$
3	Design Assistance (Shop drawings and design support, as specified in the Technical Specifications)	\$
4	Freight, as specified in the Technical Specifications	\$
5	Supervision of installation, testing, training, commissioning, warranty, and Follow-up support services. (Technical Specifications Sections 11289 and 01756)	\$
6	Total Equipment Cost (Sum of Items #1 - 5) (Sales and use taxes not included)	\$
Operation and Maintenance Costs		
7	Annual Cost for Electricity: Item #7a multiplied by the unit power cost (\$0.10/kW-hr) multiplied by 365 days per year.	\$
	a Average Power Consumption (APC) for all equipment supplied by Supplier, expressed in kilowatt-hours/day, for the average annual flow condition and average UV transmittance. ⁽¹⁾	
8	Annual lamp replacement costs: Item #8c multiplied by Item #8d.	\$
	a Number of Lamps in Service at average annual flow rate of 20 mgd and average UV transmittance of 64 percent. Include a 25 percent safety factor. Use the design End of Lamp Life and Fouling factors when calculating the required number of lamps at average conditions. Then multiple the required number of lamps at average conditions by the safety factor (1.25) to determine the Number of Lamps in Service (Ad1).	
	b Guaranteed Lamp Life, expressed in hours, for the conditions in Item #7a.	
	c Number of Lamps Replaced Per Year: Item #7a divided by Item #7b multiplied by 8,760 hours in a year.	
	d Lamp Material Cost: guaranteed not-to-exceed replacement cost for one (1) UV lamp, expressed in dollars.	\$
9	Annual ballast replacement costs: Item #9a divided by Item #9c and then multiplied by Item #9b.	\$
	a Total number of installed ballasts/lamp drivers.	
	b Guaranteed replacement cost per ballast/lamp drivers expressed in dollars.	\$
	c Guaranteed Ballast/Lamp Driver Life, expressed in years.	
10	Annual sleeve replacement costs: Item #10a divided by Item #10c and then multiplied by Item #10b.	\$
	a Total number of installed quartz sleeves.	
	b Quartz Sleeve Replacement Cost: the guaranteed not-to- exceed replacement cost of one (1) quartz sleeve, expressed in dollars.	\$
	c Guaranteed Quartz Sleeve Life, expressed in years.	

11	Annual sensor replacement costs: Item #11a divided Item #11c and then multiplied by Item #11b.		\$
	a	Total number of UV intensity sensors in the system.	
	b	UV Intensity Sensor Replacement Cost: the guaranteed not-to- exceed replacement cost of one (1) UV intensity sensor expressed in dollars.	\$
	c	Guaranteed Sensor Life, expressed in years.	
12	Cost for duty/reference sensor calibration: Item #12b multiplied by Item #12c.		\$
	a	Total number of duty/reference sensors that require calibration.	
	b	Average number of calibrations required per year.	
	c	Average cost per calibration of sensors, expressed in dollars.	\$
13	Annual cost for cleaning system consumables (Cleaning Solution, etc.)		\$
14	Annual wiper replacement cost: Item #14a divided by Item #14c and then multiplied by Item #14b.		\$
	a	Total number of automatic cleaning wipers installed in the system.	
	b	Guaranteed replacement cost per wiper, expressed in dollars.	\$
	c	Guaranteed wiper life, expressed in years.	
15	Total Annual Operational and Maintenance Cost (Sum of Items #7 - 14)		\$
16	Total Operational and Maintenance cost over 20 years (Item #15 * 20 years)		\$
17	TOTAL EQUIPMENT SUPPLY AND O&M BID (Sum of Item #6 and Item #16)		\$
Options			
Notes:			
(1) The Average Power Consumption (APC) calculation shall assume that the system will operate at conditions specified in Section 11289 of the Technical Specifications.			
(2) Value entered in Item #7 shall be equivalent to the value expected to be determined by validation testing divided by 0.80 (attenuated lamp conditions for APC calculations). This factor will be used for all manufactures for the life cycle cost analysis and is independent of the validated quartz sleeve fouling and lamp aging factors. Specific quartz sleeve fouling and lamp aging factors listed in Form 1 of Section 11289 in the Technical Specifications shall be used for sizing equipment.			

4.02 Supplier agrees that the System and the Work will be provided within the following numbers of days after Notice of Selection, and execution of Memorandum of Understanding, and payment provisions as defined in the Request for Proposal:

Delivery of Shop Drawings and Suppliers' data **4 weeks**

4.03 Supplier further agrees that performance of Supplier field services (including installation check, startup assistance, and certification of acceptable installation and operation) to final completion will be coordinated with the Contractor to the satisfaction of the CITY.

4.04 Communications concerning this Proposal shall be sent to Supplier at the following address:

4.05 The terms used in this Proposal shall have the meanings assigned to them in Section 00200 included as part of the Procurement Documents.

SIGNATURE OF SUPPLIER

By: _____
(Company Name)

By: _____
(Signature of Authorized Person)

(Name)

(Title)

(Date)

Business address: _____

Phone Number: _____ FAX Number: _____

END OF DOCUMENT

ORIGINAL AS PROPOSED
DOCUMENT 00410
PROPOSAL FORM

PROJECT IDENTIFICATION:

**City of Santa Rosa
Ultraviolet (UV) Light Disinfection Equipment System
Proposal Number 16-71**

THIS PROPOSAL IS SUBMITTED BY:

Calgon Carbon UV Technologies LLC

(Supplier)

3000 GSK Drive, Moon Township, PA 15108

(Supplier Address)

THIS PROPOSAL IS SUBMITTED TO:

BRANDALYN TRAMEL

PURCHASING AGENT

CITY OF SANTA ROSA PURCHASING OFFICE

635 FIRST ST., 2ND FLOOR

SANTA ROSA, CA 95404

707-543-3706 VOICE

Btramel@srcity.org

- 1.01 The undersigned Supplier proposes and agrees, if this Proposal is accepted, to enter into a Memorandum of Understanding with CITY in the form included in the Procurement Documents to perform and furnish all Goods and Services as specified or indicated in the Procurement Documents within the specified time and for the amount indicated in this Bid and in accordance with the other terms and conditions of the Procurement Documents.

ARTICLE 2 - SUPPLIER'S ACKNOWLEDGMENT

- 2.01 Supplier accepts all of the terms and conditions of the RFP. Supplier will execute and submit the Memorandum of Understanding and other attachments as required by the Procurement Documents and as provided in CITY's Notice of Selection, which MOU will set pricing for a period of not less than eighteen months following approval of the MOU by the CITY's Board of Public Utilities.

ARTICLE 3 - SUPPLIER'S REPRESENTATIONS

- 3.01 In submitting this Bid, the Supplier represents that:
 - A. Supplier has examined copies of all the Procurement Documents and of the following Addenda (receipt of all which is hereby acknowledged):

ADDENDA

No.	1	Dated	October 10, 2016
No.		Dated	
No.		Dated	
No.		Dated	
No.		Dated	

- B. Supplier is familiar with and has satisfied itself as to all federal, state, and local laws and regulations that may affect cost, progress, performance, and furnishing of the equipment and the Work described herein including but not limited to the requirements in the Technical Specifications and Title 22 of the California Code of Regulations.
- C. Supplier has given CITY written notice of all conflicts, errors, ambiguities, or discrepancies that Supplier has discovered in the Procurement Documents and the written resolution thereof by the CITY is acceptable to Supplier, and the Procurement Documents are generally sufficient to indicate and convey understanding of all terms and conditions for performing and furnishing the equipment and the Work identified on the Proposal.

ARTICLE 4 - BASIS OF PROPOSAL

- 4.01 Furnish the CITY with a complete UV Disinfection Systems per the attached general specifications, technical specifications and plans, and requirements. Indicate the make and model you are quoting and attach descriptive literature.

CITY OF SANTA ROSA, LAGUNA TREATMENT PLANT (LTP) PROPOSAL FORM		
Item No.	Description	Proposal Price (\$ US)
Equipment Costs		
1	UV Disinfection System, as specified in the Technical Specifications (sales and use taxes not included)	\$ 4,404,400
2	Spare parts and special tools, as specified in the Technical Specifications	\$ 113,200
3	Design Assistance (Shop drawings and design support, as specified in the Technical Specifications)	\$ 70,000
4	Freight, as specified in the Technical Specifications	\$ 63,800
5	Supervision of installation, testing, training, commissioning, warranty, and Follow-up support services. (Technical Specifications Sections 11289 and 01756)	\$ 75,100
6	Total Equipment Cost (Sum of Items #1 - 5) (Sales and use taxes not included)	\$ 4,726,500
Operation and Maintenance Costs		
7	Annual Cost for Electricity: Item #7a multiplied by the unit power cost (\$0.10/kW-hr) multiplied by 365 days per year.	\$ 307,586
	a Average Power Consumption (APC) for all equipment supplied by Supplier, expressed in kilowatt-hours/day, for the average annual flow condition and average UV transmittance. ⁽¹⁾	8427.0
8	Annual lamp replacement costs: Item #8c multiplied by Item #8d.	\$ 64,058
	a Number of Lamps in Service at average annual flow rate of 20 mgd and average UV transmittance of 64 percent. Include a 25 percent safety factor.	650
	b Guaranteed Lamp Life, expressed in hours, for the conditions in Item #7a.	16,000
	c Number of Lamps Replaced Per Year: Item #7a divided by Item #7b multiplied by 8,760 hours in a year.	355.9
	d Lamp Material Cost: guaranteed not-to-exceed replacement cost for one (1) UV lamp, expressed in dollars.	\$ 180.00
9	Annual ballast replacement costs: Item #9a divided by Item #9c and then multiplied by Item #9b.	\$ 91,000
	a Total number of installed ballasts/lamp drivers.	2600
	b Guaranteed replacement cost per ballast/lamp drivers expressed in dollars.	\$ 350.00
	c Guaranteed Ballast/Lamp Driver Life, expressed in years.	10
10	Annual sleeve replacement costs: Item #10a divided by Item #10c and then multiplied by Item #10b.	\$ 14,040
	a Total number of installed quartz sleeves.	2600
	b Quartz Sleeve Replacement Cost: the guaranteed not-to- exceed replacement cost of one (1) quartz sleeve, expressed in dollars.	\$ 81.00
	c Guaranteed Quartz Sleeve Life, expressed in years.	15

USD

11	Annual sensor replacement costs: Item #11a divided Item #11c and then multiplied by Item #11b.		\$ 3,536
	a	Total number of UV intensity sensors in the system.	25
	b	UV Intensity Sensor Replacement Cost: the guaranteed not-to- exceed replacement cost of one (1) UV intensity sensor expressed in dollars.	\$ 990.00
	c	Guaranteed Sensor Life, expressed in years.	7
12	Cost for duty/reference sensor calibration: Item #12b multiplied by Item #12c.		\$ 743
	a	Total number of duty/reference sensors that require calibration.	26
	b	Average number of calibrations required per year.	3.7
	c	Average cost per calibration of sensors, expressed in dollars.	\$ 200.00
13	Annual cost for cleaning system consumables (Cleaning Solution, etc.)		\$ 0
14	Annual wiper replacement cost: Item #14a divided by Item #14c and then multiplied by Item #14b.		\$ 4,466
	a	Total number of automatic cleaning wipers installed in the system.	650
	b	Guaranteed replacement cost per wiper, expressed in dollars.	\$ 34.00
	c	Guaranteed wiper life, expressed in years.	5
15	Total Annual Operational and Maintenance Cost (Sum of Items #7 - 14)		\$ 485,427
16	Total Operational and Maintenance cost over 20 years (Item #15 * 20 years)		\$ 9,708,541
17	TOTAL EQUIPMENT SUPPLY AND O&M BID (Sum of Item #6 and Item #16)		\$ 14,435,041 USD
Options			
Notes:			
(1) The Average Power Consumption (APC) calculation shall assume that the system will operate at conditions specified in Section 11289 of the Technical Specifications.			
(2) Value entered in Item #7 shall be equivalent to the value expected to be determined by validation testing divided by 0.80 (attenuated lamp conditions for APC calculations). This factor will be used for all manufactures for the life cycle cost analysis and is independent of the validated quartz sleeve fouling and lamp aging factors. Specific quartz sleeve fouling and lamp aging factors listed in Form 1 of Section 11289 in the Technical Specifications shall be used for sizing equipment.			

4.02 Supplier agrees that the System and the Work will be provided within the following numbers of days after Notice of Selection, and execution of Memorandum of Understanding, and payment provisions as defined in the Request for Proposal:

Delivery of Shop Drawings and Suppliers' data **4 weeks**

4.03 Supplier further agrees that performance of Supplier field services (including installation check, startup assistance, and certification of acceptable installation and operation) to final completion will be coordinated with the Contractor to the satisfaction of the CITY.

STATE OF CALIFORNIA
COUNTY OF LOS ANGELES
SUPERIOR COURT
IN AND FOR THE COUNTY OF LOS ANGELES

Case No. _____
Filed _____

Plaintiff _____

vs.

Defendant _____

FILED BY _____

SECTION 00525

MEMORANDUM OF UNDERSTANDING

The purpose of this Memorandum of Understanding (MOU) is to document the agreement between the City of Santa Rosa (CITY) and _____ (Supplier) to supply the Ultraviolet (UV) Light Disinfection System (System or UV System) for the Laguna Treatment Plant (LTP) Disinfection Improvements Project (Project).

This MOU references other documents, which are considered integral parts of this MOU. All requirements embodied in the referenced documents are inseparable requirements of this MOU.

The CITY issued a Request for Proposal, Ultraviolet Light Disinfection Equipment Procurement (RFP), which is incorporated herein by reference, to Supplier and received a proposal from _____ (Supplier) dated _____ (Proposal).

This MOU is intended to create a binding commitment between the Supplier and the CITY for acquisition of the System by CITY's contractor from Supplier pursuant to the terms and conditions of this MOU.

AGREEMENT

ARTICLE 1 - DUTIES OF SUPPLIER

Supplier shall have the following duties under this MOU:

- a. Prepare submittals for the CITY pursuant to the Technical Specifications set for in the RFP, this MOU, and Suppliers Proposal. The initial submittals shall be delivered to the CITY within four (4) weeks after execution of an agreement for professional services with the CITY as identified in the RFP.
- b. Provide coordination with the CITY in their completion through the final design of the UV system.
- c. Provide equipment supply bids to the general contractors bidding on the Project that are identical to, and in accordance with, the RFP terms and documents, Supplier's Proposal, and this MOU, as amended to include Supplier's Best and Final Offer pursuant to Section 00200, Article 2 of the RFP. The terms and conditions offered to the general contractors shall be those customary in the California public works market place, to the extent the terms and conditions are not specifically addressed herein.
- d. Deliver the System consistent with the RFP documents and approved submittals according to a schedule mutually agreed upon with the CITY's contractor and no later than 30 weeks from receipt of notice for purchase from CITY's contractor.
- e. Provide preliminary operation and maintenance (O&M) manuals with storage and installation requirements prior to delivery of System. Provide preliminary and final O&M manuals and training to CITY for operation of UV System in accordance with the Technical Specifications in the RFP.

- f. Meet other commercial warranty and risk management requirements set forth in the RFP and this MOU.

ARTICLE 2 - CITY OBLIGATIONS

Should the CITY undertake construction of the Project, it will competitively bid the public works contract in 2018 to upgrade its recycled water facilities, including installation of the UV System at its LTP at 4300 Llano Road, Santa Rosa, CA. The CITY agrees that subject to the conditions below, it shall award the public works construction contract to the lowest responsible and responsive bidder consistent with California law and the CITY Code. As a result of the RFP process, the CITY shall complete design of the Project so as to accommodate the Supplier's System and shall require CITY's contractor to purchase and install Supplier's System. The CITY shall further require that CITY's contractor obtain System equipment from Supplier in full compliance with the price and payment terms set forth in this MOU.

This obligation to obtain System from Supplier shall be conditioned upon the award of the construction contract for the Project, and the favorable result of any legal challenge to this process which could result in a court order or judgment preventing the CITY from either executing the construction contract for the Project or requiring CITY's Contractor to install Supplier's UV System equipment. If CITY fails to proceed with the Project, is prevented from entering into the construction contract, or is prevented by legal proceedings from designating Supplier's UV System equipment for inclusion in CITY's Project, CITY shall not be liable to Supplier for any damages including, but not limited to restocking, proposal preparation and contracting costs, or loss of prospective profit.

ARTICLE 3 - PRICE

The System equipment shall be manufactured, insured, and delivered for the sum of not to exceed \$ _____ dollars in US currency, exclusive of California sales tax. This total amount shall be inclusive of all payments for the Supplier's costs including those costs set forth below.

Total Equipment Supply Cost	\$ (US) _____ To be provided by the CITY to all bidders Amount is equal to the Total Proposal Cost (less the Shop Drawing and Design Assistance Cost)
------------------------------------	---

- a. The price set forth herein shall reflect shipping F.O.B. to the CITY's facility. CITY's contractor will not accept C.O.D. shipments. Supplier shall be responsible for payment of all charges for handling, shipping, packaging, wrapping, bags, container, boxing, crating, labeling, customs and duties, insurance and other related matters.
- b. Supplier agrees to offer all bidders on the Project the equipment in accordance with this MOU, as amended to include Supplier's Best and Final Offer pursuant to Section 00200, Article 2 of the RFP and as more specifically set forth in the specifications and approved shop drawings, at the proposed price and without additional terms and conditions inconsistent with this MOU. Any such additional

terms and conditions offered to proposing contractors, not inconsistent with the terms of this MOU, shall be those customary to the public works marketplace in California and in Santa Rosa, and offered at no additional cost.

- c. California Sales Tax (if applicable) will be added at the prevailing rate at time of invoicing.

ARTICLE 4 - PAYMENT TERMS AND PRICE ESCALATION

The CITY agrees to include the proposed price for the System and the following payment terms in its invitations for bids on the Project:

1. *75 percent of the sum set forth above on delivery of the System equipment to site and acceptance by CITY's contractor. This payment will include payment for all equipment.*
2. *15 percent on installation of the System.*
3. *10 percent on successful completion of performance testing, submittal and approval of O&M manual, training of CITY's employees and upon completion of the System and final acceptance of the System by the City.*

The partial payments set forth above shall be due only upon full and complete performance of each benchmark task listed above for all equipment and services required pursuant to the specifications contained in this invitation for bids.

A 5 percent retention will be withheld by CITY from each of the payments listed above. Such 5 percent retention shall be provided to CITY's contractor for payment to Supplier at the time of final payment as required by the contract documents and prevailing California law.

The Invitation for Bids shall allow for a price escalation for the System equal to increases in the (Bureau of Labor Statistics (BLS) Producer Price Index if the City's contractor fails to order the equipment within ninety (90) days from award of the construction contract for the Project and contractor shall be responsible for such costs.

ARTICLE 5 - TERMS AND CONDITIONS

1. CITY and/or CITY's contractor will review accelerometer on the delivery truck, and visually inspect shipment(s) from Supplier upon receipt at construction site to determine whether they conform to the requirements of this MOU. Notwithstanding these provisions for inspection, Supplier acknowledges that the System is not reasonably subject to mere visual inspections to ascertain whether the equipment fully conforms to the applicable specifications and that testing after installation is required prior to final acceptance of the equipment. CITY's contractor shall be required to schedule performance testing per the Technical Specifications with the assistance of the Supplier.
2. Operations Manual and Training: Supplier shall be responsible to provide an operations and maintenance manual and training to the CITY's employees as is set forth in the Technical Specification. All costs associated with provision of the operations and maintenance manual and employee training shall be included in the price set forth above.

3. Price Escalation: The costs included in this MOU shall remain in effect and are not subject to escalation for eighteen (18) months from the date of approval of the MOU by the CITY's Board of Public Utilities, provided that once the City awards a construction contract for the Project, Supplier shall be subject to its agreement with the contractor for maintaining the price of the System subject to the price escalator pursuant in the construction contract as addressed in Article 4 above.
4. Delivery of the System: Supplier shall have the equipment ready to ship at the time agreed upon with the successful bidder and delivery of the System shall be coordinated between Supplier and the City's contractor so as to avoid storage and re-shipping of the System.
5. Warranty: Supplier expressly warrants that all equipment shall conform to all Technical Specifications and final design. All equipment shall be new and of good merchantable quality, free from material defects of workmanship and fit for the purpose for which it is specified. For purposes of this warranty, any parts not meeting the foregoing quality shall be deemed defective. Supplier provides warranties on all equipment provided as set forth in the Technical Specifications. The foregoing warranty provisions shall also be applicable to equipment or software supplied to Supplier by a third party entity and provided to CITY's contractor via this MOU. Any warranties provided by third party equipment or software supplier shall be assigned to the CITY after final acceptance as defined in the Technical Specifications.
6. Liens, Claims And Encumbrances: Supplier warrants and represents that all the equipment when delivered will be free and clear of all liens, claims, encumbrances and infringements of any patents, trademarks, copyrights or franchise rights.
7. Independent Contractor: Supplier, and Supplier's employees or persons under contract to Supplier in the performance of services on this MOU, including services provided on CITY property, shall perform work as independent contractors. Supplier shall provide insurance to cover its work and its employees as required by the CITY's contractor. Further, neither party to this MOU is the agent or legal representative of the other party for any purpose, nor shall the actions of either party under this MOU create a partnership, joint venture, or relationship of principal and agent between the parties.
8. Indemnification: Supplier agrees to indemnify, protect, hold harmless and defend CITY and their officers, agents, employees, volunteers, and boards, from any and all claims or liabilities arising from any liability imposed for injury, as defined by California Government Code Section 810.8, whether arising before or after completion of the work hereunder, or in any manner, directly or indirectly caused, claimed occasioned or contributed to, by reason of any negligent act or omission of Supplier, excepting for claims or liabilities arising from active negligence of CITY. Supplier shall also indemnify, protect, hold harmless and defend CITY and CITY's Contractor for claims or liabilities arising by reason of claimed infringements of any patents, trademarks, copyrights or franchise rights, in connection with or incident to or arising out of the performance of this contract, unless the alleged infringement occurs as a result of any alteration or modification to the product or the use of the product in combination with the products or services of any party other than Seller.
9. Assignment: Supplier shall not assign any of its responsibilities under this MOU, and no such assignment will not be binding upon CITY or CITY's Contractor unless such assignment has had prior written approval of CITY, which approval shall be solely within

the discretion of CITY. Failure to obtain approval of any assignment, including an involuntary assignment to creditors, shall constitute a breach of this MOU which may lead to termination.

10. Jurisdiction: This MOU shall be administered and interpreted under the laws of the State of California, including but not limited to the Uniform Commercial Code, without regard to the conflict of laws provisions thereof. The United Nations Convention on the International Sale of Products will not apply. The jurisdiction for any litigation arising from this MOU shall be in the state of California, and its venue shall be in the County of Sonoma.
11. Modifications: No modification to this MOU, nor any waiver of any rights, shall be effective unless agreed to in writing by both Parties.
12. Liquidated Damages: The CITY's contractor may include liquidated damage penalties in its purchase agreement with Supplier to the extent that same are required of the City's contractor. Such damages should only be applicable if directly related to Supplier's failure to deliver the equipment within the time period stipulated in this MOU (30 weeks from notice for purchase from the City's contractor), failure to support the startup of the equipment, or failure of the equipment during the startup where any such failures result in a delay to the critical path of the construction project schedule. The amount of such damages in the aggregate shall not exceed ten (10) percent of the total equipment contract price as listed in this MOU.
13. Notices: All notices under this MOU shall be in writing and shall be considered delivered and effective on the earlier of actual receipt or (i) the day following transmission if sent by facsimile when followed by written confirmation by overnight carrier or certified United States mail; or (ii) one (1) day after dispatch if sent by private overnight carrier (e.g., Federal Express); or (iii) five (5) days after posting if sent by certified mail. Notice shall be sent to the following persons:

Supplier:

Contact Name:

Address:

Phone:

Fax:

E-mail:

Contractor:

Contact Name:

Address:

Phone:

Fax:

E-mail:

City:

Contact Name:

Address:

Phone:

E-mail:

ORIGINAL AS EXECUTED
MEMORANDUM OF UNDERSTANDING

The purpose of this Memorandum of Understanding (MOU) is to document the agreement between the City of Santa Rosa (CITY) and Calgon Carbon UV Technologies LLC (Supplier) to supply the Ultraviolet (UV) Light Disinfection System (System or UV System) for the Laguna Treatment Plant (LTP) Disinfection Improvements Project (Project).

This MOU references other documents, which are considered integral parts of this MOU. All requirements embodied in the referenced documents are inseparable requirements of this MOU.

The CITY issued a Request for Proposal, Ultraviolet Light Disinfection Equipment Procurement (RFP), which is incorporated herein by reference, to Supplier and received a proposal from Calgon Carbon UV Technologies LLC (Supplier) dated October 17, 2016 (Proposal).

This MOU is intended to create a binding commitment between the Supplier and the CITY for acquisition of the System by CITY's contractor from Supplier pursuant to the terms and conditions of this MOU.

AGREEMENT

ARTICLE 1 - DUTIES OF SUPPLIER

Supplier shall have the following duties under this MOU:

- a. Prepare submittals for the CITY pursuant to the Technical Specifications set for in the RFP, this MOU, and Suppliers Proposal. The initial submittals shall be delivered to the CITY within four (4) weeks after execution of an agreement for professional services with the CITY as identified in the RFP.
- b. Provide coordination with the CITY in their completion through the final design of the UV system.
- c. Provide equipment supply bids to the general contractors bidding on the Project that are identical to, and in accordance with, the RFP terms and documents, Supplier's Proposal, and this MOU, as amended to include Supplier's Best and Final Offer pursuant to Section 00200, Article 2 of the RFP. The terms and conditions offered to the general contractors shall be those customary in the California public works market place, to the extent the terms and conditions are not specifically addressed herein.
- d. Deliver the System consistent with the RFP documents and approved submittals according to a schedule mutually agreed upon with the CITY's contractor and no later than 30 weeks from receipt of notice for purchase from CITY's contractor.
- e. Provide preliminary operation and maintenance (O&M) manuals with storage and installation requirements prior to delivery of System. Provide preliminary and final O&M manuals and training to CITY for operation of UV System in accordance with the Technical Specifications in the RFP.

- f. Meet other commercial warranty and risk management requirements set forth in the RFP and this MOU.

ARTICLE 2 - CITY OBLIGATIONS

Should the CITY undertake construction of the Project, it will competitively bid the public works contract in 2018 to upgrade its recycled water facilities, including installation of the UV System at its LTP at 4300 Llano Road, Santa Rosa, CA. The CITY agrees that subject to the conditions below, it shall award the public works construction contract to the lowest responsible and responsive bidder consistent with California law and the CITY Code. As a result of the RFP process, the CITY shall complete design of the Project so as to accommodate the Supplier's System and shall require CITY's contractor to purchase and install Supplier's System. The CITY shall further require that CITY's contractor obtain System equipment from Supplier in full compliance with the price and payment terms set forth in this MOU.

This obligation to obtain System from Supplier shall be conditioned upon the award of the construction contract for the Project, and the favorable result of any legal challenge to this process which could result in a court order or judgment preventing the CITY from either executing the construction contract for the Project or requiring CITY's Contractor to install Supplier's UV System equipment. If CITY fails to proceed with the Project, is prevented from entering into the construction contract, or is prevented by legal proceedings from designating Supplier's UV System equipment for inclusion in CITY's Project, CITY shall not be liable to Supplier for any damages including, but not limited to restocking, proposal preparation and contracting costs, or loss of prospective profit.

ARTICLE 3 - PRICE

The System equipment shall be manufactured, insured, and delivered for the sum of not to exceed \$ 4,726,500 dollars in US currency, exclusive of California sales tax. This total amount shall be inclusive of all payments for the Supplier's costs including those costs set forth below.

Total Equipment Supply Cost	<p>\$ (US) <u>4,656,500</u> To be provided by the CITY to all bidders</p> <p>Amount is equal to the Total Proposal Cost (less the Shop Drawing and Design Assistance Cost)</p>
------------------------------------	---

- a. The price set forth herein shall reflect shipping F.O.B. to the CITY's facility. CITY's contractor will not accept C.O.D. shipments. Supplier shall be responsible for payment of all charges for handling, shipping, packaging, wrapping, bags, container, boxing, crating, labeling, customs and duties, insurance and other related matters.
- b. Supplier agrees to offer all bidders on the Project the equipment in accordance with this MOU, as amended to include Supplier's Best and Final Offer pursuant to Section 00200, Article 2 of the RFP and as more specifically set forth in the specifications and approved shop drawings, at the proposed price and without additional terms and conditions inconsistent with this MOU. Any such additional

terms and conditions offered to proposing contractors, not inconsistent with the terms of this MOU, shall be those customary to the public works marketplace in California and in Santa Rosa, and offered at no additional cost.

- c. California Sales Tax (if applicable) will be added at the prevailing rate at time of invoicing.

ARTICLE 4 - PAYMENT TERMS AND PRICE ESCALATION

The CITY agrees to include the proposed price for the System and the following payment terms in its invitations for bids on the Project:

1. *75 percent of the sum set forth above on delivery of the System equipment to site and acceptance by CITY's contractor. This payment will include payment for all equipment.*
2. *15 percent on installation of the System.*
3. *10 percent on successful completion of performance testing, submittal and approval of O&M manual, training of CITY's employees and upon completion of the System and final acceptance of the System by the City.*

The partial payments set forth above shall be due only upon full and complete performance of each benchmark task listed above for all equipment and services required pursuant to the specifications contained in this invitation for bids.

A 5 percent retention will be withheld by CITY from each of the payments listed above. Such 5 percent retention shall be provided to CITY's contractor for payment to Supplier at the time of final payment as required by the contract documents and prevailing California law.

The Invitation for Bids shall allow for a price escalation for the System equal to increases in the (Bureau of Labor Statistics (BLS) Producer Price Index if the City's contractor fails to order the equipment within ninety (90) days from award of the construction contract for the Project and contractor shall be responsible for such costs.

ARTICLE 5 - TERMS AND CONDITIONS

1. CITY and/or CITY's contractor will review accelerometer on the delivery truck, and visually inspect shipment(s) from Supplier upon receipt at construction site to determine whether they conform to the requirements of this MOU. Notwithstanding these provisions for inspection, Supplier acknowledges that the System is not reasonably subject to mere visual inspections to ascertain whether the equipment fully conforms to the applicable specifications and that testing after installation is required prior to final acceptance of the equipment. CITY's contractor shall be required to schedule performance testing per the Technical Specifications with the assistance of the Supplier.
2. Operations Manual and Training: Supplier shall be responsible to provide an operations and maintenance manual and training to the CITY's employees as is set forth in the Technical Specification. All costs associated with provision of the operations and maintenance manual and employee training shall be included in the price set forth above.

3. Price Escalation: The costs included in this MOU shall remain in effect and are not subject to escalation for eighteen (18) months from the date of approval of the MOU by the CITY's Board of Public Utilities, provided that once the City awards a construction contract for the Project, Supplier shall be subject to its agreement with the contractor for maintaining the price of the System subject to the price escalator pursuant in the construction contract as addressed in Article 4 above.
4. Delivery of the System: Supplier shall have the equipment ready to ship at the time agreed upon with the successful bidder and delivery of the System shall be coordinated between Supplier and the City's contractor so as to avoid storage and re-shipping of the System.
5. Warranty: Supplier expressly warrants that all equipment shall conform to all Technical Specifications and final design. All equipment shall be new and of good merchantable quality, free from material defects of workmanship and fit for the purpose for which it is specified. For purposes of this warranty, any parts not meeting the foregoing quality shall be deemed defective. Supplier provides warranties on all equipment provided as set forth in the Technical Specifications. The foregoing warranty provisions shall also be applicable to equipment or software supplied to Supplier by a third party entity and provided to CITY's contractor via this MOU. Any warranties provided by third party equipment or software supplier shall be assigned to the CITY after final acceptance as defined in the Technical Specifications.
6. Liens, Claims And Encumbrances: Supplier warrants and represents that all the equipment when delivered will be free and clear of all liens, claims, encumbrances and infringements of any patents, trademarks, copyrights or franchise rights.
7. Independent Contractor: Supplier, and Supplier's employees or persons under contract to Supplier in the performance of services on this MOU, including services provided on CITY property, shall perform work as independent contractors. Supplier shall provide insurance to cover its work and its employees as required by the CITY's contractor. Further, neither party to this MOU is the agent or legal representative of the other party for any purpose, nor shall the actions of either party under this MOU create a partnership, joint venture, or relationship of principal and agent between the parties.
8. Indemnification: Supplier agrees to indemnify, protect, hold harmless and defend CITY and their officers, agents, employees, volunteers, and boards, from any and all claims or liabilities arising from any liability imposed for injury, as defined by California Government Code Section 810.8, whether arising before or after completion of the work hereunder, or in any manner, directly or indirectly caused, claimed occasioned or contributed to, by reason of any negligent act or omission of Supplier, excepting for claims or liabilities arising from active negligence of CITY. Supplier shall also indemnify, protect, hold harmless and defend CITY and CITY's Contractor for claims or liabilities arising by reason of claimed infringements of any patents, trademarks, copyrights or franchise rights, in connection with or incident to or arising out of the performance of this contract, unless the alleged infringement occurs as a result of any alteration or modification to the product or the use of the product in combination with the products or services of any party other than Seller.
9. Assignment: Supplier shall not assign any of its responsibilities under this MOU, and no such assignment will not be binding upon CITY or CITY's Contractor unless such assignment has had prior written approval of CITY, which approval shall be solely within

the discretion of CITY. Failure to obtain approval of any assignment, including an involuntary assignment to creditors, shall constitute a breach of this MOU which may lead to termination.

10. Jurisdiction: This MOU shall be administered and interpreted under the laws of the State of California, including but not limited to the Uniform Commercial Code, without regard to the conflict of laws provisions thereof. The United Nations Convention on the International Sale of Products will not apply. The jurisdiction for any litigation arising from this MOU shall be in the state of California, and its venue shall be in the County of Sonoma.
11. Modifications: No modification to this MOU, nor any waiver of any rights, shall be effective unless agreed to in writing by both Parties.
12. Liquidated Damages: The CITY's contractor may include liquidated damage penalties in its purchase agreement with Supplier to the extent that same are required of the City's contractor. Such damages should only be applicable if directly related to Supplier's failure to deliver the equipment within the time period stipulated in this MOU (30 weeks from notice for purchase from the City's contractor), failure to support the startup of the equipment, or failure of the equipment during the startup where any such failures result in a delay to the critical path of the construction project schedule. The amount of such damages in the aggregate shall not exceed ten (10) percent of the total equipment contract price as listed in this MOU.
13. Notices: All notices under this MOU shall be in writing and shall be considered delivered and effective on the earlier of actual receipt or (i) the day following transmission if sent by facsimile when followed by written confirmation by overnight carrier or certified United States mail; or (ii) one (1) day after dispatch if sent by private overnight carrier (e.g., Federal Express); or (iii) five (5) days after posting if sent by certified mail. Notice shall be sent to the following persons:

Supplier:

Contact Name: Christopher Todd
Address: 3000 GSK Dr., Moon Township, PA 15108
Phone: 724-218-7244
Fax:
E-mail: christodd@calgoncarbon.com

Contractor:

Contact Name:
Address:
Phone:
Fax:
E-mail:

City:

Contact Name:
Address:
Phone:
E-mail:

SECTION 00550

**CITY OF SANTA ROSA
PROFESSIONAL SERVICES AGREEMENT
WITH [NAME OF SUPPLIER]
AGREEMENT NUMBER _____**

This "Agreement" is made as of this ____ day of _____, 2016 [leave date blank until all parties have signed or until Council approves], by and between the City of Santa Rosa, a municipal corporation ("City"), and [add Supplier's full name, for example, "XYZ Sales Corporation" or "ABC Consulting, LLC" or "ABC Enterprises, LP" or "John Smith, dba Smith Consulting"], a [add type of legal entity and state of entity formation or incorporation, for example, a "California Corporation" or a "Delaware Limited Liability Company" or a "Nevada Limited Partnership" or a "sole proprietor"] ("Supplier").

RECITALS

A. City desires to upgrade the existing Ultraviolet (UV) Light Disinfection System for the Laguna Treatment Plant (LTP) Disinfection Improvements Project (Project).

B. City desires to retain a qualified Supplier to provide UV Disinfection System equipment submittals and design assistance in accordance with the Scope of Services as more particularly set forth in the Technical Specifications of the RFP dated September 22, 2016, and summarized in Exhibit A to the Agreement.

C. Supplier represents to City that it is a firm composed of highly trained professionals and is fully qualified to conduct the services described above and render advice to City in connection with said services.

D. The parties have negotiated upon the terms pursuant to which Supplier will provide such services and have reduced such terms to writing.

AGREEMENT

NOW, THEREFORE, City and Supplier agree as follows:

1. SCOPE OF SERVICES

Supplier shall provide to City with equipment submittals and design assistance services described in the Technical Specifications of the RFP dated September 22, 2016, and summarized in Exhibit A ("Scope of Services") [attach either City's description of the services to be provided or Consultant's proposal and mark as Exhibit A]. Supplier shall provide these services at the time, place, and in the manner specified in Exhibit A. Exhibit A is attached hereto for the purpose of defining the manner and scope of services to be provided by Supplier and is not intended to, and shall not be construed so as to, modify or expand the terms, conditions or provisions contained in this Agreement. In the event of any conflict between this Agreement and any terms or conditions of any document prepared or provided by Supplier and made a part of this Agreement, including without limitation any document relating to the scope of services or payment therefor, the terms of this Agreement shall control and prevail.

2. COMPENSATION

a. City shall pay Supplier for services rendered pursuant to this Agreement at the rates, times and in the manner set forth in Exhibit B. Supplier shall submit monthly statements to City which shall itemize the services performed as of the date of the statement and set forth a progress report, including work accomplished during the period, percent of each task completed, and planned effort for the next period. Invoices shall identify personnel who have worked on the services provided, the number of hours each worked during the period covered by the invoice, the hourly rate for each person, and the percent of the total project completed, consistent with the rates and amounts shown in Exhibit B.

b. The payments prescribed herein shall constitute all compensation to Supplier for all costs of services, including, but not limited to, direct costs of labor of employees engaged by Supplier, travel expenses, telephone charges, copying and reproduction, computer time, and any and all other costs, expenses and charges of Supplier, its agents and employees. In no event shall City be obligated to pay late fees or interest, whether or not such requirements are contained in Supplier's invoice.

c. Notwithstanding any other provision in this Agreement to the contrary, the total maximum compensation to be paid for the satisfactory accomplishment and completion of all services to be performed hereunder shall in no event exceed the sum of [enter maximum amount in written and numeric form, for example – "ten-thousand, five-hundred dollars and no cents (\$10,500.00)"]. The City's Chief Financial Officer is authorized to pay all proper claims from Charge Number [enter IFAS charge number].

3. DOCUMENTATION; RETENTION OF MATERIALS

a. Supplier shall maintain adequate documentation to substantiate all charges as required under Section 2 of this Agreement.

b. Supplier shall keep and maintain full and complete documentation and accounting records concerning all extra or special services performed by it that are compensable by other than an hourly or flat rate and shall make such documents and records available to authorized representatives of City for inspection at any reasonable time.

c. Supplier shall maintain the records and any other records related to the performance of this Agreement and shall allow City access to such records during the performance of this Agreement and for a period of four (4) years after completion of all services hereunder.

4. INDEMNITY

a. Supplier shall, to the fullest extent permitted by law, indemnify, protect, defend and hold harmless City, and its employees, officials and agents ("Indemnified Parties") from all claims, demands, costs or liability (including liability for claims, suits, actions, arbitration proceedings, administrative proceedings, regulatory proceedings, losses, expenses or costs of any kind, interest, defense costs, and expert witness fees), that arise out of, pertain to, or relate to the negligence, recklessness, or willful misconduct of Supplier, its officers, employees, or agents, in said performance of professional services under this Agreement, excepting only liability arising from the sole negligence, active negligence or intentional misconduct of City.

b. The existence or acceptance by City of any of the insurance policies or coverages described in this Agreement shall not affect or limit any of City's rights under this Section 4, nor shall the limits of such insurance limit the liability of Supplier hereunder. This Section 4 shall not apply to any intellectual property claims, actions, lawsuits or other proceedings subject to the provisions of Section 17(b), below. The provisions of this Section 4 shall survive any expiration or termination of this Agreement.

5. INSURANCE

a. Supplier shall maintain in full force and effect all of the insurance coverage described in, and in accordance with, Attachment One, "Insurance Requirements." Maintenance of the insurance coverage set forth in Attachment One is a material element of this Agreement and a material part of the consideration provided by Supplier in exchange for City's agreement to make the payments prescribed hereunder. Failure by Supplier to (i) maintain or renew coverage, (ii) provide City notice of any changes, modifications, or reductions in coverage, or (iii) provide evidence of renewal, may be treated by City as a material breach of this Agreement by Supplier, whereupon City shall be entitled to all rights and remedies at law or in equity, including but not limited to immediate termination of this Agreement. Notwithstanding the foregoing, any failure by Supplier to maintain required insurance coverage shall not excuse or alleviate Supplier from any of its other duties or obligations under this Agreement. In the event Supplier, with approval of City pursuant to Section 6 below, retains or utilizes any subcontractors or subSuppliers in the provision of any services to City under this Agreement, Supplier shall assure that any such subcontractor has first obtained, and shall maintain, all of the insurance coverages set forth in the Insurance Requirements in Attachment One.

b. Supplier agrees that any available insurance proceeds broader than or in excess of the coverages set forth in the Insurance Requirements in Attachment One shall be available to the additional insureds identified therein.

c. Supplier agrees that the insurance coverages and limits provided under this Agreement are the greater of: (i) the coverages and limits specified in Attachment One, or (ii) the broader coverages and maximum limits of coverage of any insurance policy or proceeds available to the name insureds.

6. ASSIGNMENT

Supplier shall not assign any rights or duties under this Agreement to a third party without the express prior written consent of City, in City's sole and absolute discretion. Supplier agrees that the City shall have the right to approve any and all subcontractors and subSuppliers to be used by Supplier in the performance of this Agreement before Supplier contracts with or otherwise engages any such subcontractors or subSuppliers.

7. NOTICES

Except as otherwise provided in this Agreement, any notice, submittal or communication required or permitted to be served on a party, shall be in writing and may be served by personal delivery to the person or the office of the person identified below. Service may also be made by mail, by placing first-class postage, and addressed as indicated below, and depositing in the United States mail to:

City Representative:

Supplier Representative:

[Include name of Project Manager]
[Include Address and Telephone and
Facsimile Number]

[Include name of Project
Manager]
[Include Address, Telephone and
Facsimile Number]

8. INDEPENDENT CONTRACTOR

a. It is understood and agreed that Supplier (including Supplier’s employees) is an independent contractor and that no relationship of employer-employee exists between the parties hereto for any purpose whatsoever. Neither Supplier nor Supplier’s assigned personnel shall be entitled to any benefits payable to employees of City. City is not required to make any deductions or withholdings from the compensation payable to Supplier under the provisions of this Agreement, and Supplier shall be issued a Form 1099 for its services hereunder. As an independent contractor, Supplier hereby agrees to indemnify and hold City harmless from any and all claims that may be made against City based upon any contention by any of Supplier’s employees or by any third party, including but not limited to any state or federal agency, that an employer-employee relationship or a substitute therefor exists for any purpose whatsoever by reason of this Agreement or by reason of the nature and/or performance of any services under this Agreement.

b. It is further understood and agreed by the parties hereto that Supplier, in the performance of Supplier’s obligations hereunder, is subject to the control and direction of City as to the designation of tasks to be performed and the results to be accomplished under this Agreement, but not as to the means, methods, or sequence used by Supplier for accomplishing such results. To the extent that Supplier obtains permission to, and does, use City facilities, space, equipment or support services in the performance of this Agreement, this use shall be at the Supplier’s sole discretion based on the Supplier’s determination that such use will promote Supplier’s efficiency and effectiveness. Except as may be specifically provided elsewhere in this Agreement, the City does not require that Supplier use City facilities, equipment or support services or work in City locations in the performance of this Agreement.

c. If, in the performance of this Agreement, any third persons are employed by Supplier, such persons shall be entirely and exclusively under the direction, supervision, and control of Supplier. Except as may be specifically provided elsewhere in this Agreement, all terms of employment, including hours, wages, working conditions, discipline, hiring, and discharging, or any other terms of employment or requirements of law, shall be determined by Supplier. It is further understood and agreed that Supplier shall issue W-2 or 1099 Forms for income and employment tax purposes, for all of Supplier’s assigned personnel and subcontractors.

d. The provisions of this Section 8 shall survive any expiration or termination of this Agreement. Nothing in this Agreement shall be construed to create an exclusive relationship between City and Supplier. Supplier may represent, perform services for, or be employed by such additional persons or companies as Supplier sees fit.

9. ADDITIONAL SERVICES

Changes to the Scope of Services shall be by written amendment to this Agreement and shall be paid on an hourly basis at the rates set forth in Exhibit B, or paid as otherwise agreed upon by the parties in writing prior to the provision of any such additional services.

10. SUCCESSORS AND ASSIGNS

City and Supplier each binds itself, its partners, successors, legal representatives and assigns to the other party to this Agreement and to the partners, successors, legal representatives and assigns of such other party in respect of all promises and agreements contained herein.

11. TERM, SUSPENSION, TERMINATION

a. This Agreement shall become effective on the date that it is made, set forth on the first page of the Agreement, and shall continue in effect until both parties have fully performed their respective obligations under this Agreement, unless sooner terminated as provided herein.

b. City shall have the right at any time to temporarily suspend Supplier's performance hereunder, in whole or in part, by giving a written notice of suspension to Supplier. If City gives such notice of suspension, Supplier shall immediately suspend its activities under this Agreement, as specified in such notice.

c. City shall have the right to terminate this Agreement for convenience at any time by giving a written notice of termination to Supplier. Upon such termination, Supplier shall submit to City an itemized statement of services performed as of the date of termination in accordance with Section 2 of this Agreement. These services may include both completed work and work in progress at the time of termination. City shall pay Supplier for any services for which compensation is owed; provided, however, City shall not in any manner be liable for lost profits that might have been made by Supplier had the Agreement not been terminated or had Supplier completed the services required by this Agreement. Supplier shall promptly deliver to City all documents related to the performance of this Agreement in its possession or control. All such documents shall be the property of City without additional compensation to Supplier.

12. TIME OF PERFORMANCE

The services described herein shall be provided during the period, or in accordance with the schedule, set forth in Exhibit A. Supplier shall complete all the required services and tasks and complete and tender all deliverables to the reasonable satisfaction of City, not later than [enter expected completion date].

13. STANDARD OF PERFORMANCE

Supplier shall perform all services performed under this Agreement in the manner and according to the standards currently observed by a competent practitioner of Supplier's profession in California. All products of whatsoever nature that Supplier delivers to City shall be prepared in a professional manner and conform to the standards of quality normally observed by a person currently practicing in Supplier's profession, and shall be provided in accordance with any schedule of performance. Supplier shall assign only competent personnel to perform services under this Agreement. Supplier shall notify City in writing of any changes in Supplier's staff assigned to perform the services under this Agreement prior to any such performance. In the event that City, at any time, desires the removal of any person assigned by Supplier to perform services under this Agreement, because City, in its sole discretion, determines that such person is not performing in accordance with the standards required herein, Supplier shall remove such person immediately upon receiving notice from City of the desire of City for the removal of such person.

14. CONFLICTS OF INTEREST

Supplier covenants that neither it, nor any officer or principal of its firm, has or shall acquire any interest, directly or indirectly, that would conflict in any manner with the interests of City or that would in any way hinder Supplier's performance of services under this Agreement. Supplier further covenants that in the performance of this Agreement, no person having any such interest shall be employed by it as an officer, employee, agent or subcontractor, without the written consent of City. Supplier agrees to avoid conflicts of interest or the appearance of any conflicts of interest with the interests of City at all times during the performance of this Agreement.

15. CONFLICT OF INTEREST REQUIREMENTS

a. **Generally.** The City's Conflict of Interest Code requires that individuals who qualify as "Suppliers" under the Political Reform Act, California Government Code sections 87200 *et seq.*, comply with the conflict of interest provisions of the Political Reform Act and the City's Conflict of Interest Code, which generally prohibit individuals from making or participating in the making of decisions that will have a material financial effect on their economic interests. The term "Supplier" generally includes individuals who make governmental decisions or who serve in a staff capacity.

b. **Conflict of Interest Statements.** The individual(s) who will provide services or perform work pursuant to this Agreement are "Suppliers" within the meaning of the Political Reform Act and the City's Conflict of Interest Code:

yes no (*check one*)

If "yes" is checked by the City, Supplier shall cause the following to occur within 30 days after execution of this Agreement:

- (1) Identify the individuals who will provide services or perform work under this Agreement as "Suppliers"; and
- (2) Cause these individuals to file with the City Clerk the assuming office statements of economic interests required by the City's Conflict of Interest Code.

Thereafter, throughout the term of the Agreement, Supplier shall cause these individuals to file with the City Clerk annual statements of economic interests, and "leaving office" statements of economic interests, as required by the City's Conflict of Interest Code.

The above statements of economic interests are public records subject to public disclosure under the California Public Records Act. The City may withhold all or a portion of any payment due under this Agreement until all required statements are filed.

16. CONFIDENTIALITY OF CITY INFORMATION

During performance of this Agreement, Supplier may gain access to and use City information regarding inventions, machinery, products, prices, apparatus, costs, discounts, future plans, business affairs, governmental affairs, processes, trade secrets, technical matters, systems, facilities, customer lists, product design, copyright, data, and other vital information (hereafter collectively referred to as "City Information") that are valuable, special and unique assets of the City. Supplier agrees to protect all City Information and treat it as strictly confidential, and further agrees that Supplier shall not at any time, either directly or indirectly, divulge, disclose or communicate in any manner any City Information to any third party without the prior written consent of City. In addition, Supplier shall comply with all City policies governing the use of the City network and technology systems. A violation by Supplier of this Section 16 shall be a material violation of this Agreement and shall justify legal and/or equitable relief.

17. SUPPLIER INFORMATION

a. City shall have full ownership and control, including ownership of any copyrights, of all information prepared, produced, or provided by Supplier pursuant to this Agreement. In this Agreement, the term "information" shall be construed to mean and include: any and all work product, submittals, reports, plans, specifications, and other deliverables consisting of documents, writings, handwritings, typewriting, printing, photostatting, photographing, computer models, and any other computerized data and every other means of recording any form of information, communications, or representation, including letters, works, pictures, drawings, sounds, or symbols, or any combination thereof. Supplier shall not be responsible for any unauthorized modification or use of such information for other than its intended purpose by City.

b. Supplier shall fully defend, indemnify and hold harmless City, its officers and employees, and each and every one of them, from and against any and all claims, actions, lawsuits or other proceedings alleging that all or any part of the information prepared, produced, or provided by Supplier pursuant to this Agreement infringes upon any third party's trademark, trade name, copyright, patent or other intellectual property rights. City shall make reasonable efforts to notify Supplier not later than ten (10) days after City is served with any such claim, action, lawsuit or other proceeding, provided that City's failure to provide such notice within such time period shall not relieve Supplier of its obligations hereunder, which shall survive any termination or expiration of this Agreement.

c. All proprietary and other information received from Supplier by City, whether received in connection with Supplier's proposal, will be disclosed upon receipt of a request for disclosure, pursuant to the California Public Records Act; provided, however, that, if any information is set apart and clearly marked "trade secret" when it is provided to City, City shall give notice to Supplier of any request for the disclosure of such information. Supplier shall then have five (5) days from the date it receives such

notice to enter into an agreement with the City, satisfactory to the City Attorney, providing for the defense of, and complete indemnification and reimbursement for all costs (including plaintiff's attorneys' fees) incurred by City in any legal action to compel the disclosure of such information under the California Public Records Act. Supplier shall have sole responsibility for defense of the actual "trade secret" designation of such information.

d. The parties understand and agree that any failure by Supplier to respond to the notice provided by City and/or to enter into an agreement with City, in accordance with the provisions of subsection c, above, shall constitute a complete waiver by Supplier of any rights regarding the information designated "trade secret" by Supplier, and such information shall be disclosed by City pursuant to applicable procedures required by the Public Records Act.

18. MISCELLANEOUS

a. Entire Agreement. This Agreement contains the entire agreement between the parties. Any and all verbal or written agreements made prior to the date of this Agreement are superseded by this Agreement and shall have no further effect.

b. Modification. No modification or change to the terms of this Agreement will be binding on a party unless in writing and signed by an authorized representative of that party.

c. Compliance with Laws. Supplier shall perform all services described herein in compliance with all applicable federal, state and local laws, rules, regulations, and ordinances, including but not limited to, (i) the Americans with Disabilities Act of 1990 (42 U.S.C. 12101, et seq.) ("ADA"), and any regulations and guidelines issued pursuant to the ADA; and (ii) Labor Code sections 1720, et seq., which require prevailing wages (in accordance with DIR determinations at www.dir.ca.gov) be paid to any employee performing work covered by Labor Code sections 1720 et seq. Supplier shall pay to the City when due all business taxes payable by Supplier under the provisions of Chapter 6-04 of the Santa Rosa City Code. The City may deduct any delinquent business taxes, and any penalties and interest added to the delinquent taxes, from its payments to Supplier.

d. Discrimination Prohibited. With respect to the provision of services under this Agreement, Supplier agrees not to discriminate against any person because of the race, religious creed, color, national origin, ancestry, physical disability, mental disability, medical condition, genetic information, marital status, sex, gender, gender identity, gender expression, age, sexual orientation, or military and veteran status of that person.

e. Governing Law; Venue. This Agreement shall be governed, construed and enforced in accordance with the laws of the State of California. Venue of any litigation arising out of or connected with this Agreement shall lie exclusively in the state trial court in Sonoma County in the State of California, and the parties consent to jurisdiction over their persons and over the subject matter of any such litigation in such court, and consent to service of process issued by such court.

f. Waiver of Rights. Neither City acceptance of, or payment for, any service or performed by Supplier, nor any waiver by either party of any default, breach or condition precedent, shall be construed as a waiver of any provision of this Agreement, nor as a waiver of any other default, breach or condition precedent or any other right hereunder.

g. Incorporation of Attachments and Exhibits. The attachments and exhibits to this Agreement are incorporated and made part of this Agreement, subject to terms and provisions herein contained.

19. AUTHORITY; SIGNATURES REQUIRED FOR CORPORATIONS

Supplier hereby represents and warrants to City that it is (a) a duly organized and validly existing [enter type of entity], formed and in good standing under the laws of the State of [enter state of formation for corporations, LPs and LLCs], (b) has the power and authority and the legal right to conduct the business in which it is currently engaged, and (c) has all requisite power and authority and the legal right to consummate the transactions contemplated in this Agreement. Supplier hereby further represents and warrants that this Agreement has been duly authorized, and when executed by the signatory or signatories listed below, shall constitute a valid agreement binding on Supplier in accordance with the terms hereof.

If this Agreement is entered into by a corporation, it shall be signed by two corporate officers, one from each of the following two groups: a) the chairman of the board, president or any vice-president; b) the secretary, any assistant secretary, chief financial officer, or any assistant treasurer. The title of the corporate officer shall be listed under the signature.

Executed as of the day and year first above stated.

SUPPLIER:

CITY OF SANTA ROSA
a Municipal Corporation

Name of Firm: _____

TYPE OF BUSINESS ENTITY (check one):

By: _____

- _____ Individual/Sole Proprietor
- _____ Partnership
- _____ Corporation
- _____ Limited Liability Company
- _____ Other (please specify: _____)

Print Name: _____

Title: _____

Signatures of Authorized Persons:

APPROVED AS TO FORM:

By: _____

Print Name: _____

Title: _____

By: _____

Print Name: _____

Title: _____

Office of the City Attorney

ATTEST:

City Clerk

[Remove signature block if agreement not approved by Council]

City of Santa Rosa Business Tax Cert. No.

Attachments:

Attachment One - Insurance Requirements

Exhibit A - Scope of Services

Exhibit B - Compensation

END OF DOCUMENT

@ #	AT (MEASUREMENT) DEFLECTION ANGLE, CENTRAL ANGLE NUMBER (REBAR Ø)
A	ANCHOR BOLT
ABC	ADREGATE BASE COURSE
ABS	ACRYLONITRILE BUTADIENE STYRENE
AC	ASPHALTIC CONCRETE
ACB	AIR CIRCUIT BREAKER
ACI	AMERICAN CONCRETE INSTITUTE
ACP	ASBESTOS CEMENT PIPE
ACU	AIR CONDITIONING UNIT
AD	AREA DRAIN
ADDL	ADDITIONAL
ADJ	ADJACENT, ADJUST, ADJUSTABLE
ADMIN	ADMINISTRATION
ADR	ACCESS DOOR
AED	AREA EQUIPMENT DRAIN
AER	AERAT(ION)(OR)
AFC	AFTERCooler
AF	ABOVE FINISHED FLOOR
AFM	AIR FLOW MONITOR
AHU	AIR HANDLING UNIT
AIC	AIR COMPRESSOR
AIL	AIR INTAKE LOUVER
ALT	ALTERNATE
AL	ALUMINUM
ANCH	ANCHOR
ANV	ANGLE VALVE
APPROX	APPROXIMATE, APPROXIMATELY
ARCH	ARCHITECTURAL
ARV	AIR RELEASE VALVE
ASSY	ASSEMBLY
ASTM	AMERICAN SOCIETY FOR TESTING AND MATERIALS
AV	ACID VENT
AVG	AVERAGE
AVV	AIR AND VACUUM VALVE
AW	ACID WASTE
BC	BEGIN CURVE, BRASS CAP, BACK OF CURB, BOLT CIRCLE
BCKR	BACKER BOARD
BCM	BATCHMETER
BD	BOARD
BDD	BACKDRAFT DAMPER
BDR	BASIN DRAIN LINE
BF	BLIND FLANGE
BFG	BELOW FINISHED GRADE
BFP	BELT FILTER PRESS
BFV	BUTTERFLY VALVE
BG	BREAK GLASS HAND SWITCH
BKW	BACKWASH
BLDG	BUILDING
BLK	BLOCK
BLKHD	BULKHEAD
BLR	PROCESS BLOWER
BM	BEAM, BENCH MARK
BOTT	BOTTOM
BOTTS	BOTTOM SLUDGE
BPV	BACK PRESSURE VALVE
BRG	BEARING
BSR	BLACK STEEL PIPE
BTU	BRITISH THERMAL UNITS
BTWN	BETWEEN
BV	BALL VALVE
C	CLOSE, CONDUIT CHANNEL (STRUCTURAL)
CA	CONCRETE ANCHOR
CAUSTIC	CAUSTIC SOLUTION (CONCENTRATED OR DILUTE)
CB	CATCH BASIN
CC	CENTER OF CURVATURE, CENTER TO CENTER
CCB	CHLORINE CONTACT BASIN
CD	CEILING DIFFUSER, CONDENSATE DRAIN
CDL	CHEMICAL DRAIN LINE
CONDUIT	CONDUIT
CEFT	CEILING EXHAUST FAN
CF	CUBIC FEET
CFM	CUBIC FEET PER MINUTE
CFS	CUBIC FEET PER SECOND
CHEMD	CHEMICAL DRAIN
CHF	CHEMICAL FEEDER
CHKD PL	CHECKERED PLATE
CJ	CAST IRON
CP	CAST IRON PIPE
CIRC	CIRCUMFERENTIAL/CIRCUMFERENCE
CJ	CONSTRUCTION JOINT
CKA	CHECK VALVE, ANGLE
CKB	CHECK VALVE, BALL
CKF	CHECK VALVE, FLAP
CKS	CHECK VALVE, SWING
CL	CENTER LINE
CLK	CHAIN LINK
CLD	CHLORINE LEAK DETECTOR
CLL	CHLORINE LIQUID
CLP	CHLORINE GAS (PRESSURE)
CLR	CLEAR
CLS	CHLORINE SOLUTION
CLSM	CONTROLLED LOW STRENGTH MATERIAL
CLV	CHLORINE GAS (VACUUM)
CML	CEMENT MORTAR LINED
CMLC	CEMENT MORTAR LINED AND COATED
CMP	CORRUGATED METAL PIPE
CMU	CONCRETE MASONRY UNIT
CNV	CONVEYOR
CO	CLEANOUT
COL(S)	COLUMN(S)
CONC	CONCRETE
CONN	CONNECT, CONNECTION
CONST	CONSTRUCTION
CONT	CONTINUOUS OR CONTINUATION OR (D) (OUS)
CORR	CORRUGATE(D), CORROSION
CP	CONTROL POINT
CPLG	COUPLING
CPT	CARPET
CPVC	CHLORINATED POLYVINYL CHLORIDE
CS	CARBON STEEL, CIRCULATING SLUDGE
CSP	CHEMICAL SUMP PUMP, CORRUGATED STEEL PIPE
CT	CURRENT TRANSFORMER, CERAMIC TILE
CTJ	CONTROL JOINT
CTR	CONTROL, CENTERED
CTSK	COUNTERSUNK
CU	CUBIC
CUP	COPPER PIPE
CV	CHECK VALVE
CW	COLD WATER
CWV	COMBINATION WASTE AND VENT
CY	CUBIC YARD
D	DEPTH, DIGITAL OR DISCRETE, DRAIN
D/W	DRIVEWAY
DBL	DOUBLE
DDR	DESICCANT DRYER
DEG or °	DEGREE
DEMO	DEMOLISH, DEMOLITION
DET	DETAIL
DFL	DECANT/FILTRATE
DG	DOOR GRILLE
DIA or Ø	DIAMETER
DIAG	DIAGONAL
DIF	DIFFUSER
DIG	DIGESTER
DIM	DIMENSION
DIP	DUCTILE IRON PIPE
DISCH	DISCHARGE
DIW	DEIONIZED WATER
DL	DEAD LOAD, DRAIN LINE
DLV	DOOR LOUVER
DMP	DAMPER
DMS	DIAPHRAGM SEAL
DN	DOWN
do	DITTO
DO	DOOR OPENING
DP	DEEP (OR DEPTH)
DPV	DIAPHRAGM VALVE
DR	DOOR, DRAIN
DRT	DRIP TRAP
DRV	DRAIN VALVE
DSE	DIGESTED SLUDGE, DOWN SPOUT
DSW	DISTILLED WATER, DOOR SWITCH
DUC	HOSE BIBB
DUH	DUCT HEATER UNIT
DW	DISTILLED WATER
DWD	DEWATERING DRAIN
DWG(S)	DRAWING(S)
DWL(S)	DOWEL(S)
E	EAST
EA	EACH
EC	END OF CURVE
ECC RED	ECCENTRIC REDUCER
ECU	EVAPORATOR COOLING UNIT
ED	EQUIPMENT DRAIN
EF	EXHAUST FAN, EACH FACE
EFF	EFFLUENT
EG	EXHAUST GRILLE
EIFS	EXTERIOR INSULATION AND FINISH SYSTEM
EJ	EXPANSION JOINT
EJR	INJECTOR/REDUCTOR
EL	ELEVATION
ELEC	ELECTRICAL
ELL	ELBOW
EMBED	EMBEDMENT
EMH	ELECTRICAL MANHOLE
EP	EDGE OF PAVEMENT
EPS	EXPANDED POLYSTYRENE
EPV	ECCENTRIC PLUG VALVE
EQ	EQUAL
EQUIP	EQUIPMENT
ER	EXHAUST REGISTER
ES	EACH SIDE
ESEW	EMERGENCY SHOWER AND EYE WASH
ESS	EMERGENCY HAND SWITCH
ET	ELECTRICALLY HEAT TRACED
EUH	ELECTRIC UNIT HEATER
EVR	EVAPORATOR
EW	EACH WAY
EWIC	ELECTRIC WATER COOLER
EWEF	EACH WAY EACH FACE
EWH	ELECTRIC WATER HEATER, EXHAUST
EX	EXISTING
EXIST	EXISTING
EXP	EXPANSION, EXPANSION TANK
EXPO	EXPOSED
EXT	EXTERIOR
F	FACTORY
FAD	FOUL AIR DUCT
FB	FLAT BAR
FBW	FILTER BACKWASH
FC	FACE OF CURB, FLEXIBLE COUPLING
FCA	FLANGE COUPLING ADAPTER
FCO	FLOOR CLEANOUT
FCU	FAN COIL UNIT
FD	FIRE DAMPER, FLOOR DRAIN, FLOOD
FDC	FIRE DEPARTMENT CONNECTION
FDL	FLOOR DRAIN LINE
FDR	FEDER
FEFF	FINAL EFFLUENT
FG	FLAP GATE
FG	FLAP GATE
FH	FIRE HYDRANT
FILT	FILTRATE
FIN	FINISH
FIN FL	FINISHED FLOOR
FIN GR	FINISHED GRADE
FL	FLOOR, FLOW LINE
FLA	FOUL AIR
FLD	FILTER DRAIN
FLE	FILTER EFFLUENT
FLEX	FLEXIBLE
FLG	FLANGE, OR FLANGED
FLR	FILTER
FM	FORCE MAIN
FND	FOUNDATION
FO	FUEL OIL
FPM	FEET PER MINUTE
PPP	FLEXIBLE PLASTIC PIPE
FRP	FIBERGLASS REINFORCED PLASTIC
FRPP	FIBERGLASS REINFORCED PLASTIC PIPE
FROTH	FROTH SPRAY
FS	FAR SIDE
FSTN	FASTEN(ED)
FT or'	FOOT, FEET
FTG	FOOTING
FUP	FUEL DISPENSER
FV	FLAP VALVE
FW	FLUSHING WATER
FX	FIRE EXTINGUISHER
FXC	FIRE EXTINGUISHER CABINET
FXE	FIRE EXTINGUISHER - ELECTRICAL
G	GAS, GROUND, GUTTER
GA	GAUGE or GAGE
GAL	GALLONS
GALV	GALVANIZE(D)
GAV	GRAVITY VENTILATOR
GB	GRADE BREAK
GBT	GRAVITY BELT THICKENER
GC	GROOVED COUPLING
GEL	GRAVITY EXHAUST LOUVER
GEN	GENERAL, GENERATOR
GL	GLASS
GLV	GLOBE VALVE
GM	GAS METER
GND	GROUND
GPD	GALLONS PER DAY
GPM	GALLONS PER MINUTE
GR	GRADE
GRTG	GRAVITY
GRV	GRAVITY VENTILATOR
GSP	GALVANIZED STEEL PIPE
GV	GATE VALVE
GYP	GYPsum
H	EXPLOSION-PROOF, HIGH, HORIZONTAL
H1E	HOOK ONE END
H2E	HOOK TWO ENDS
HAS	HEADED ANCHOR STUD
HB	HOSE BIBB
HCS	SODIUM HYPOCHLORITE
HDPE	HIGH DENSITY POLYETHYLENE
HDW	HEADWARE
HDWL	HEADWALL
HEF	HOOD EXHAUST FAN
HGT	HEIGHT
HORIZ	HORIZONTAL
HP	HEAT PUMP, HORSEPOWER, HIGH PRESSURE
HPA	HIGH PRESSURE AIR
HPT	HIGH POINT
HPU	HEAT PUMP UNIT AIR
HR	HANDRAIL, HOSE REEL, HOUR
HSF	HOOD SUPPLY FAN
HSS	HOLLOW STRUCTURAL SECTION (STEEL)
HTX	HEAT EXCHANGER
HV	HOSE VALVE
HW	HOT WATER
HWL	HIGH WATER LEVEL
HWR	HOT WATER RETURN
HWS	HOT WATER SUPPLY
HxW	HEIGHT BY WIDTH
HYD	HYDRANT
I	INSTRUMENT AIR
ID	INSIDE DIAMETER, INSIDE DIMENSION, IDENTIFICATION
IF	INSIDE FACE
IN or"	INCHES
INCL	INCLUDE, INCLUDING
INF	INFLUENT
INJ	INJECTOR
INSTR	INSTRUMENTATION
INSUL	INSULAT(E)(D)(ING)(ION)
INT	INTERIOR
INV	INVERT
IP	IRON PIPE
ISR	INTRINSICALLY SAFE RELAY
J	JOIST
JT	JOINT
K	KNIFE GATE VALVE
KGV	KNIFE GATE VALVE
L	ANGLE (STRUCTURAL), LENGTH, LOUVER
LAB	LABORATORY
LAV	LAVATORY
LB(S)	POUND(S)
LDF	LIQUID DIESEL FUEL
LDFR	LIQUID DIESEL FUEL RETURN
LF	LINEAL FEET
LONG	LONG
LH	LEFT HAND
LHR	LEFT HAND REVERSE
LHRA	LEFT HAND REVERSE ACTIVE
LHRB	LEFT HAND REVERSE BEVEL
LL	LIVE LOAD
LLH	LONG LEG HORIZONTAL
LLV	LONG LEG VERTICAL
LP	LOW PRESSURE
LPA	LOW PRESSURE AIR
LPG	LIQUIFIED PROPANE GAS
LPT	LOW POINT
LR	LONG RADIUS
LS	LAB SINK
LT	LEFT
LWL	LOW WATER LEVEL
M	MOTOR
MANNT	MAINTENANCE
MAN	MANUAL
MASY	MASONRY
MATL	MATERIAL
MAU	MAKE-UP AIR UNIT
MAX	MAXIMUM
MB	MACHINE BOLT
MC	MECHANICAL COUPLING
MCJ	MASONRY CONTROL JOINT
MD	MOTORIZED DAMPER
MECH	MECHANICAL
MET	METAL
MFR	MANUFACTURER
MGL	MILLIGRAMS PER LITER
MGD	MILLION GALLONS PER DAY
MH	MANHOLE
MIN	MINIMUM
MISC	MISCELLANEOUS
MIX	MIXER
MJ	MECHANICAL JOINT
MK	MARK
ML	MIXED LIQUOR
MO	MASONRY OPENING
MOD	MODIFIED
MOIST	MOISTURE
MON	MONUMENT
MOS	MOISTURE SEPARATOR
MPM	METERING PUMP
MS	MOP SINK
MTD	MOUNTED
N	NORTH, NEUTRAL
NA	NOT APPLICABLE
NC	NORMALLY CLOSED
NEV	VALVE, NEEDLE
NG	NATURAL GRADE, NATURAL OR LP GAS
NIC	NOT IN CONTRACT
NO, #	NUMBER
NOM	NOMINAL
NPT	NATIONAL PIPE THREAD
NPW	NON-POTABLE WATER
NS	NEAR SIDE
NTS	NOT TO SCALE
O	OPEN
OBD	OPPOSED BLADE DAMPER
OC	ON CENTER
OD	OUTSIDE DIAMETER, OUTSIDE DIMENSION
OED	OPEN EQUIPMENT DRAIN
O.F.	OUTSIDE FACE
OFL	OVERFLOW
OPNG	OPENING
OPST	OPPOSITE
OPP HND	OPPOSITE HAND
OZ	OUNCE
P	POLE
PBL	POLYMER BLENDER
PC	POINT OF CURVATURE
PCC	PLANT CONTROL CENTER
PCCP	PRESTRESSED CONCRETE CYLINDER PIPE
PCP	PROGRESSIVE CAVITY PUMP
PD	POSITIVE DISPLACEMENT, PLANT DRAIN
PD, PLD	PULSATION DAMPENOR
PDP	POSITIVE DISPLACEMENT PUMP
PE	PLAIN END
PERP	PERPENDICULAR
PG	PRESSURE GAUGE
PH	PHASE, PHYSICALLY HANDICAPPED
PI	POINT OF INTERSECTION
PIV	POST INDICATOR VALVE
PL	PLATE, PROPERTY LINE
PLAS	PLASTIC
PLCS	PLACES
PLS	POLYMER SOLUTION
PLWD	PLYWOOD
PMP	PUMP
PNL(S)	PANEL(S)
POL	POLYMER
POLY	POLYETHYLENE
POSITION	POSITION
PP	POTABLE WATER
POWER POLE	POWER POLE
PPMV	PARTS PER MILLION (VOLUME)
PRC	POINT OF REVERSE CURVATURE
PREFAB	PREFABRICATED
PRG	PRESSURE REGULATOR
PRI	PRIMARY
PROJ	PROJECTION
PRR	PRESSURE OR VACUUM RELIEF VALVE
PRV	PRESSURE REDUCING VALVE, PRESSURE REGULATION VALVE, PRESSURE RELIEF VALVE
PS	PUMP STATION, PIPE SUPPORT
PSF	POUNDS PER SQUARE FOOT
PSG	PRESSURE GAUGE
PSI	POUNDS PER SQUARE INCH
PSIG	POUNDS PER SQUARE INCH GAUGE
PT	POINT, POINT OF TANGENCY
PV	PLUG VALVE
PVC	POINT OF VERTICAL CURVATURE, POLYVINYL CHLORIDE
PVDF	POLYVINYLIDENEFLUORIDE
PVI	POINT OF VERTICAL INTERSECTION
PVMT	PAVEMENT
PVT	POINT OF VERTICAL TANGENCY
PLW	PLANT WATER
QTY	QUANTITY
R/W	RIGHT OF WAY
RAD	RADIUS, RADIAL
RAS	RETURN ACTIVATED SLUDGE
RCP	REINFORCED CONCRETE PIPE
RD	ROOF DRAIN
RDL	ROOF DRAIN LINE
RD/OF	ROOF DRAIN OVERFLOW
RECIRC	RE-CIRCULATING
RED	REDUCER, ROOF EQUIPMENT DRAIN
REF	REFERENCE
REG	REGULATOR, REGULATING
REINF	REINFORCE(D)(ING)(MENT)
REJ	RUBBER EXPANSION JOINT
REQD	REQUIRED
RES	REACTOR
RES	RESERVOIR
REV	REVISION, REVERSE
RF	RETURN FAN
RG	RETURN GRILLE RUBBER GASKET
RH	RIGHT HAND
RHR	RIGHT HAND REVERSE
RHRA	RIGHT HAND REVERSE ACTIVE
RHRB	RIGHT HAND REVERSE BEVEL
RLS	REGISTERED LAND SURVEYOR
RM	ROOM
RO	ROUGH OPENING
ROT	ROTAMETER
RUD	RADIUS POINT
RPM	REVOLUTIONS PER MINUTE
RPMP	REINFORCED PLASTIC MORTAR PIPE
RR	RETURN REGISTER
RSR	RISER
RT	RIGHT
RTF	ROTARY FEEDER
RTU	ROOF TOP UNIT
RUP	RUPTURE DISK
RW	RECLAIMED WATER, REUSE WATER
RWR	RECLAIMED WATER RETURN
RWW	RAW WASTEWATER
S	SIDEWALK
SW	SOUTH, SWITCH, SLOPE
SA	SAMPLE
SC	SECONDARY CLARIFIER
SCB	SCRUBBER
SCD	SMOKE CONTROL DAMPER
SCFM	STANDARD CUBIC FEET PER MINUTE
SCH	SCHEDULE
SCO	SURFACE CLEANOUT
SCR	BAR SCREEN
SCR	SILICON CONTROL RECTIFIER
SD	SMOKE DETECTOR, SPLITTER DAMPER, STORM DRAIN
SDL	SUMP DISCHARGE DRAIN LINE
SDO	SLUDGE DRAFFOFF
SE	SECONDARY EFFLUENT
SEC	SECONDARY, SECOND
SECTION	SECTION
SED	SEDIMENTATION
SEP	SEPTAGE
SF	SUPPLY FAN
SWF	SOFTENED WATER
SG	SUPPLY GRILLE
SGS	STORE FRONT GLAZING SYSTEM
SHD	SHOWER DRAIN
SHDR	SOLIDS HANDLING-RECYCLE
SHR	SHOWER
SHT	SHEET
SIM	SIMILAR
SK	SKIMMINGS
SL	SLOPE, SLUDGE
SLC	SLUDGE COLLECTOR DRIVE
SLG	SLIDE GATE
SMP	SLEEVE VALVE
SMP	SAMPLER, SUMP PUMP
SN	SUPERNATANT OR SUBNATANT
SOL	SOLUTION
SP	STATIC PRESSURE, SET POINT
SPD	SUMP PUMP DRAIN
SPDT	SINGLE POLE DOUBLE THROW
SPEC(S)	SPECIFICATION(S)
SPL	SPLITTER BOX
SPR	SPARE
SPS	SAMPLE SINK
SPW	SAMPLE WATER
SQ	SQUARE
SQ FT	SQUARE FEET
SQ IN(S)	SQUARE INCH(ES)
SR	SHORT RADIUS, SUPPLY REGISTER
SRL	SCRUBBER RECIRCULATION LIQUID (CAUSTIC)
SS	SANITARY SEWER, SELECTOR SWITCH
SSK	SERVICE SINK
SSL	SECONDARY SLUDGE
ST	SLUDGE TRANSFER
ST STL	STAINLESS STEEL
STA	STATION
STB	STABILIZER
STD(S)	STANDARD(S)
STIFF	STIFFENER
STIRRUPS	STIRRUPS
STL	STEEL
STM	STEAM
STP	STEEL PIPE
STR	STRAINER
STRUCT	STRUCTURAL
SUG	SLUDGE GATE
SUPT	PIPE SUPPORT, SUPPORT
SV	SERVICE VALVE, SHUTOFF VALVE, SOLENOID VALVE
SW	SANITARY WASTE
SWR	SEAL WATER
SYM	SYMMETRICAL
SYN	SYNTHETIC
T	TANGENT LENGTH, THERMOSTAT, TIMER
T&B	TOP AND BOTTOM
TAS	THREADED ANCHOR STUD
TBM	TEMPORARY BENCHMARK
TC	TOP OF CURB
TCV	TEMPERATURE CONTROL VALVE
TDH	TOTAL DYNAMIC HEAD
TDR	TIME DELAY RELAY, TOWEL DISPENSER/RECEPTACLE
TEL	TELEPHONE
TH	TEST HOLE
THK	THICKENER, THICKNESS, THICK
TKS	THICKENED SLUDGE
TLV	TELESCOPING VALVE
TMH	TELEPHONE MANHOLE
TMP	TEMPERATURE
TNK	TANK
T.O.	TOP OF
TOC	TOP OF CONCRETE
TOG	TOP OF GRATING
TOM	TOP OF MASONRY
TOS	TOP OF STEEL
TOW	TOP OF WALL
TR	TRIAD (THREE CONDUCTOR SHIELDED CABLE), TIMING RELAY
TRD	TREAD
TS	THICKENER SUPERNATANT OR SUBNATANT
TSD	THICKENER SLUDGE DECANT
TSPL	TURBIDIMETER SAMPLE
TSTAT	THERMOSTAT
TTB	TELEPHONE TERMINAL BOARD
TUR	TURBINE
TV	TURNING VANES
TWV	

Plot Date: 05-DEC-2019 10:51:28 AM

User: svcPW

Model: Layout1 ColorTable: gshade.ctb DesignScript: Carollo_Stu_Pen_v0905.pen PlotScale: 2:1



C
M03

B
M03

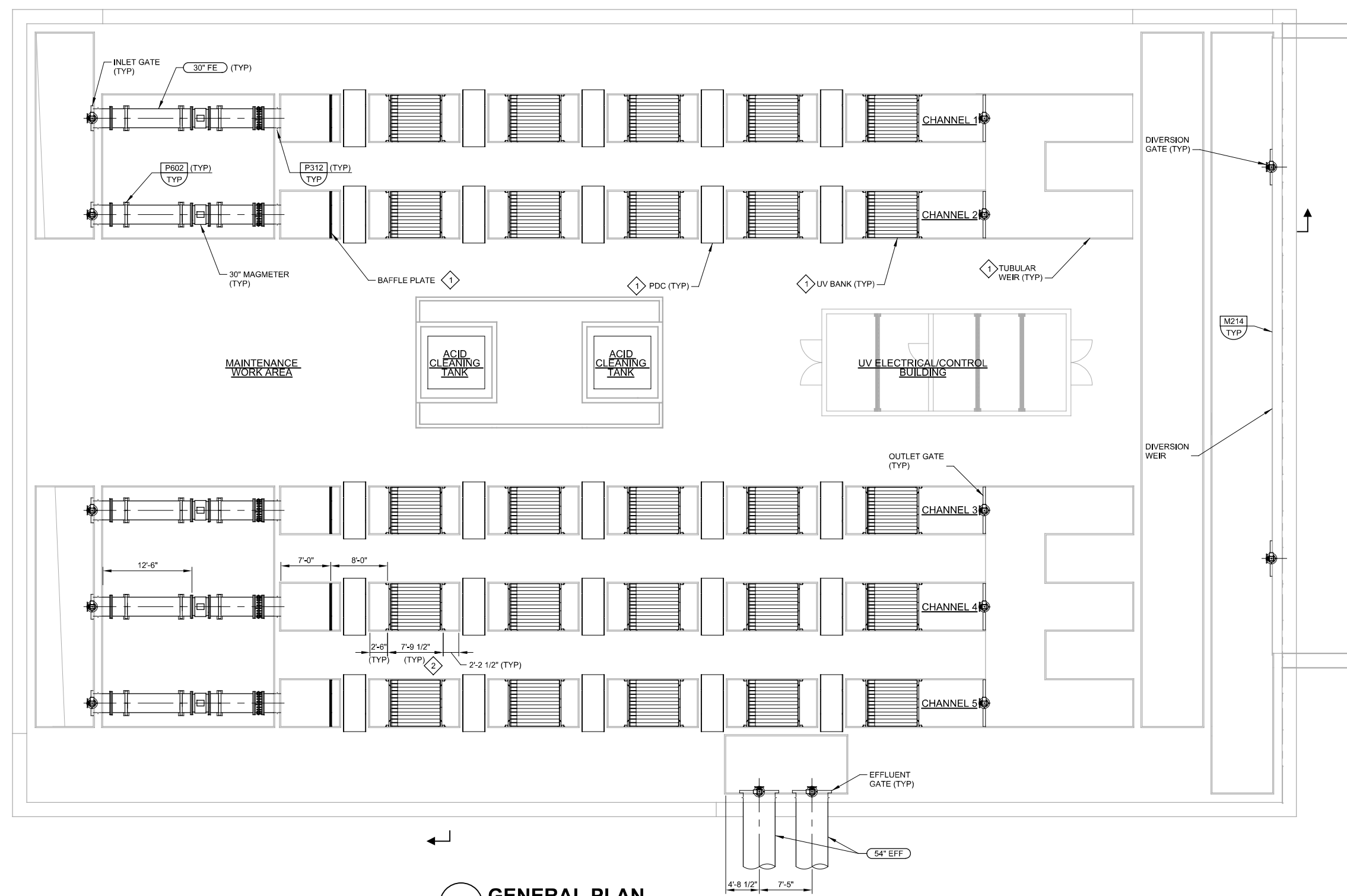

- GENERAL NOTES:**
- XXXX
 - XXXX
- KEY NOTES:**
- SUPPLIED BY UV SYSTEM SUPPLIER.
 - DISTANCE BETWEEN CENTERLINE OF UV BANK RACK GUIDES PROVIDED BY UV SYSTEM SUPPLIER.

A GENERAL PLAN
 SCALE: 1/8" = 1'-0"
 FILE: 8871G1SM101

Price Request Update December 2019

VERIFY SCALES
 BAR IS ONE INCH ON ORIGINAL DRAWING
 0 1"
 IF NOT ONE INCH ON THIS SHEET, ADJUST SCALES ACCORDINGLY

75% INTERMEDIATE DESIGN SUBMITTAL NOT FOR CONSTRUCTION



Date	Revision	By

CITY OF SANTA ROSA
LAGUNA TREATMENT PLANT
 Disinfection Improvements Project

UV FACILITY OVERALL PLAN

CONTRACT NO. XXXXXX
 Date: FEBRUARY 2020 Scale: AS SHOWN
 APPROVED: Deputy Director - Engineering
 By: _____ Date: _____
 DWN: _____ DATE: _____
 CHK: _____ DATE: _____
 DES: KR DATE: _____
 Drw No. M01 File Number: 2016-0018
 Sheet ___ of XX

LTP DISINFECTION IMPROVEMENTS

ELECTRICAL PLAN SYMBOLS

IDENTIFICATION SYMBOLS

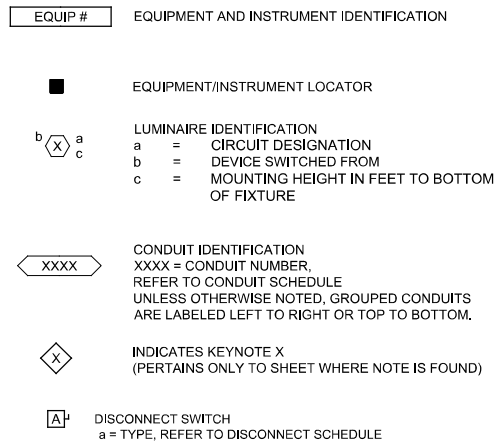

GROUNDING

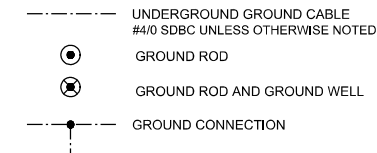

LUMINAIRES

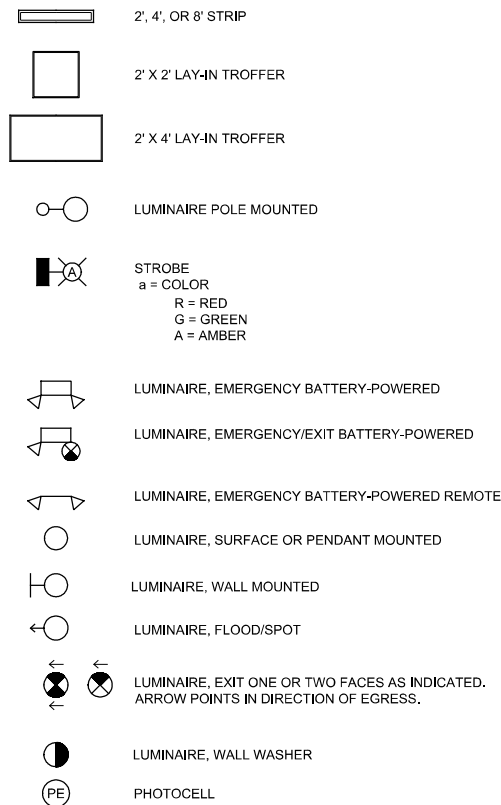

SWITCHES/RECEPTACLES

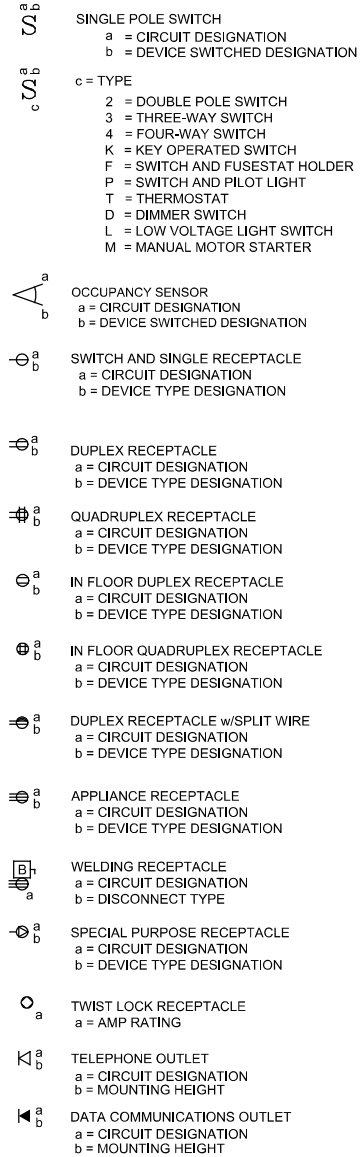

FIRE ALARM

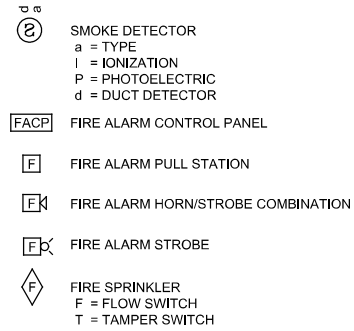

RACEWAY

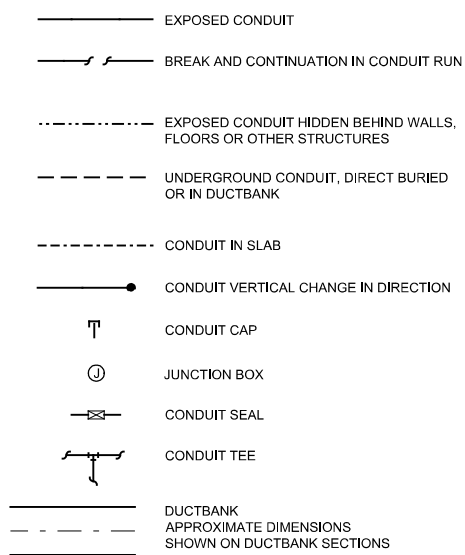

CONDUIT SIZE AND CONDUCTORS

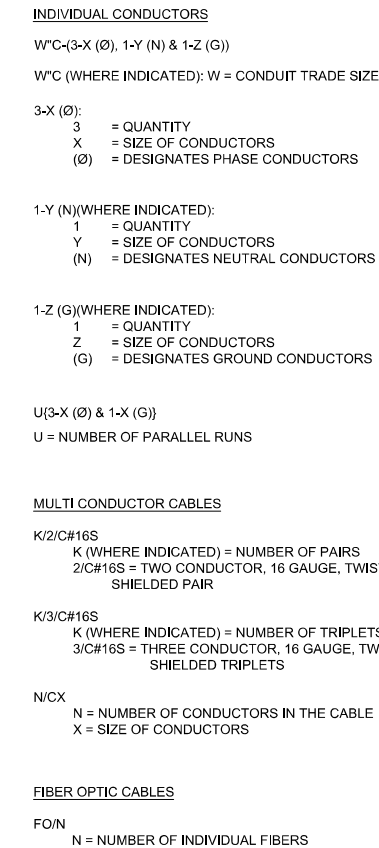

MEDIUM VOLTAGE

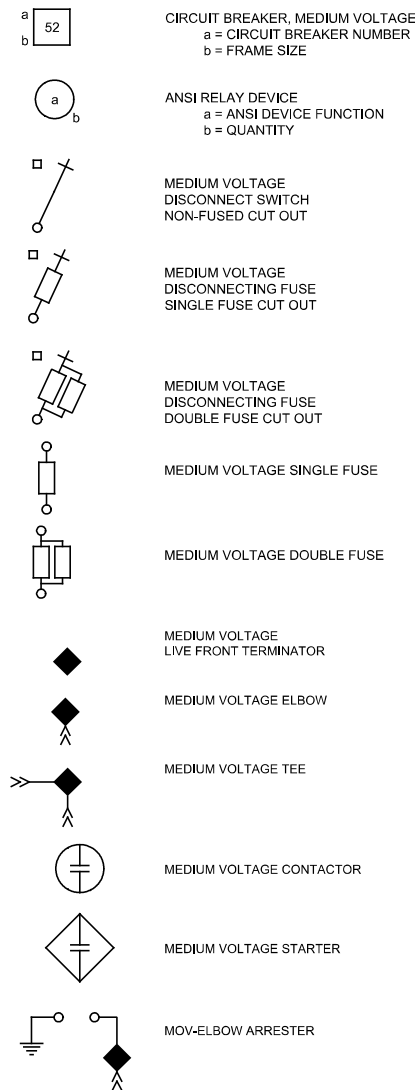

Price Request Update December 2019

ELECTRICAL ONE-LINE SYMBOLS

LOW VOLTAGE

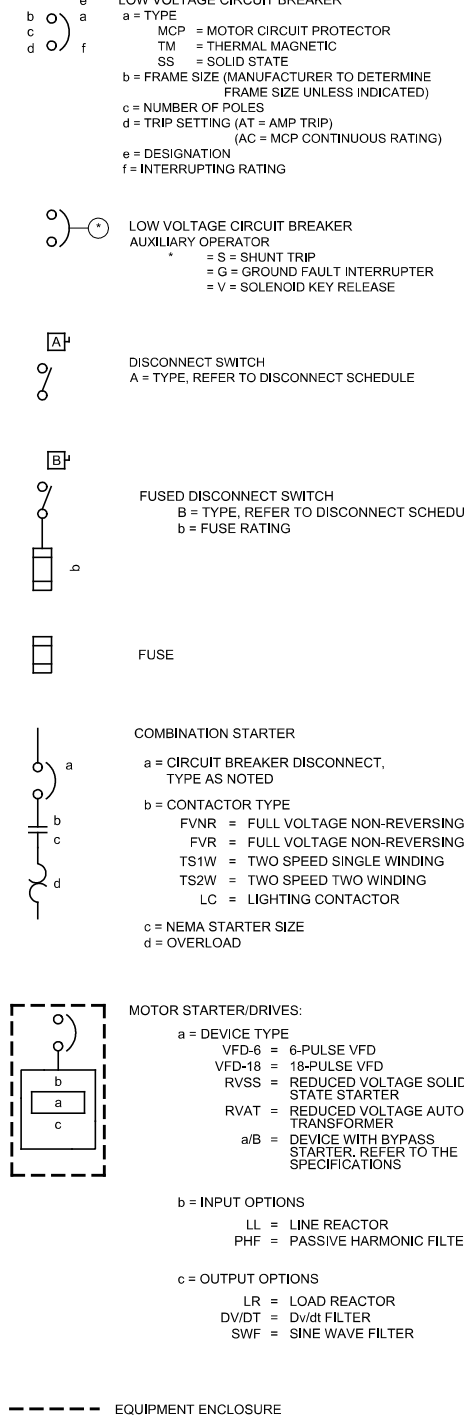

MISCELLANEOUS

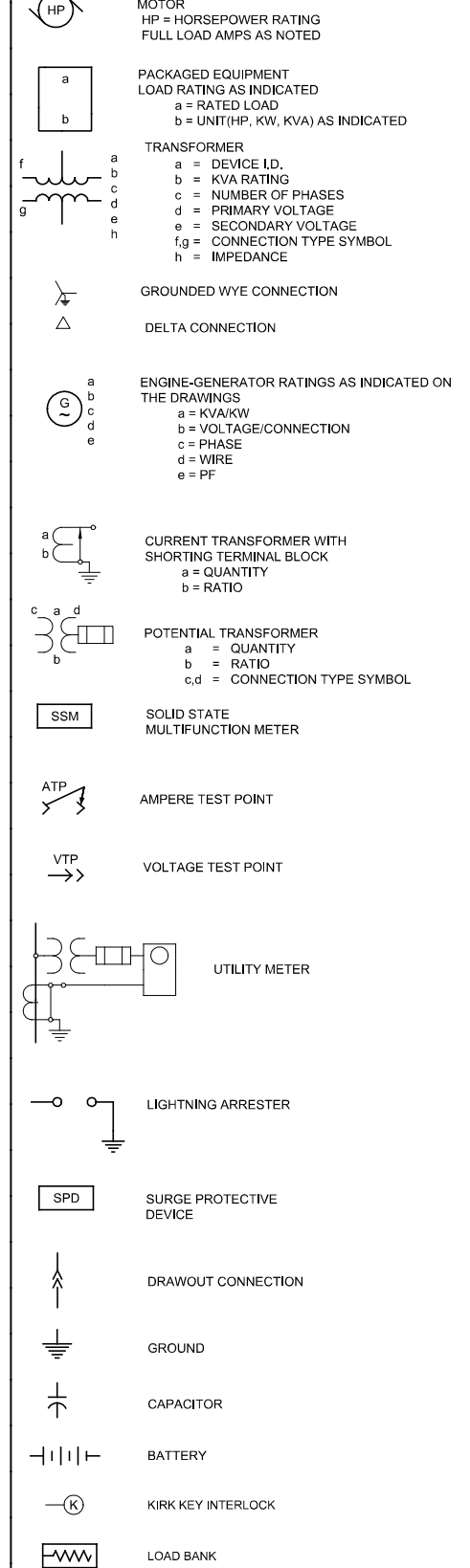

VERIFY SCALES
BAR IS ONE INCH ON ORIGINAL DRAWING
IF NOT ONE INCH ON THIS SHEET, ADJUST SCALES ACCORDINGLY

PRELIMINARY DESIGN SUBMITTAL NOT FOR CONSTRUCTION



CITY OF SANTA ROSA
LAGUNA TREATMENT PLANT ULTRAVIOLET (UV) LIGHT DISINFECTION EQUIPMENT SYSTEM
ELECTRICAL LEGEND

CONTRACT NO. XXXXXX
Date: SEPTEMBER 2016 Scale: AS SHOWN
APPROVED: Deputy Director - Engineering
By: _____ Date: _____
DWN LP DATE: _____
CHK CAC DATE: 5-1-16
DES BS DATE: 5-1-16
Drw No. GE01
Sheet 13 of 28
File Number: 2016-0018

Date	Revision	By

ABBREVIATIONS

Table of abbreviations including AMP, ABS, AC, ACK, ACTR, AF, AFC, AIC, AM, ANN, ANT, APU, ARM, AS, ASYM, AT, ATO, ATP, ATS, AUTO XFMR, AUX, AWG, B, BAT, BFG, BHP, BKR, BRF, C, CB, CCTV, CCW, CKT, COAX, COM, COMM, CPT, CS, CT, CV, CW, DC, DCS, DCU - X, DEMO, DISC, DM, DPDT, DS, E/G, EM, EMT, ENCL, ENG, ENT, EP, ETM, FA, FACP, FDR, FLA, FLX, FO, FRC, FREQ, FU, FVNR, FVR, FWD, G, GEN, GRC, GFCI, GFI, GFR, H, HF, HP, HPS, HR, HSTAT, HV, HVAC, HZ, I, IC, IJB, IMC, INST, INT, INTERCOM, J, K, KA, KV, KVA, KVAR, KW, KWD, KWH, L, L-B, L-G, LA, LBL, LC, LCP - X, LL, LP, LP - X, LTG, LV, LVL, M, M-X, MA, MCA, MCC - X, MCP, MH, MLO, MOD, MOV, MRP, MS-X, MSP, MTO, MTR-X, MTS, MV, MVA, MVS, MW, N, NC, NEC, NFC, NL, NO, NP, O, OH, OL, P, PA, PB, PCS, PCM, PE, PF, PFCC, PFR, PH, PNL, PPX, PRI, PT, PVC, PWR, RAC, RECPT, REV, RF, RMS, RVAT, RVNR, RVSS, S, SA, SC, SDBC, SFL, SLT, SM, SP, SPD, SPDT, SPST, SPKR, SS, STB, SW, SWBD, SWGR, SYM, TACH, TB - X, TC, TD, TE, TEFC, TENV, TERM, TJB, TM, TP, TS, TS1W, TS2W, TSTAT, UHF, UNG, UPS, UVR, V, VA, VAR, VCP, VFD, VHF, VM, VP, VR, VS, VT, VTP, W, WT, WP, XFMR

POWER DEVICE FUNCTION NUMBERS

Table of power device function numbers 1-84 including MASTER ELEMENT, TIME-DELAY STARTING OR CLOSING RELAY, CHECKING OR INTERLOCKING RELAY, MASTER CONTACTOR, STOPPING DEVICE, STARTING CIRCUIT BREAKER, ANODE CIRCUIT BREAKER, CONTROL POWER DISCONNECTING DEVICE, REVERSING DEVICE, UNIT SEQUENCE SWITCH, MULTIFUNCTION DEVICE, OVER-SPEED DEVICE, SYNCHRONOUS-SPEED DEVICE, UNDER-SPEED DEVICE, SPEED OR FREQUENCY MATCHING DEVICE, DATA COMMUNICATIONS DEVICE, SHUNTING OR DISCHARGE SWITCH, ACCELERATING OR DECELERATING DEVICE, STARTING-TO-RUNNING TRANSITION CONTACTOR, ELECTRICALLY OPERATED VALVE, DISTANCE RELAY, EQUALIZER CIRCUIT BREAKER, TEMPERATURE CONTROL DEVICE, VOLTS PER HERTZ RELAY, SYNCHRONIZING OR SYNCHRONISM-CHECK DEVICE, APPARATUS THERMAL DEVICE, UNDERVOLTAGE RELAY, GROUND FAULT UNDERVOLTAGE RELAY, FLAME DETECTOR, ISOLATING CONTACTOR, ANNUNCIATOR RELAY, SEPARATE EXCITATION DEVICE, DIRECTIONAL POWER RELAY, POSITION SWITCH, MASTER SEQUENCE DEVICE, BRUSH-OPERATING OR SLIP-RING SHORT-CIRCUITING DEVICE, POLARITY DEVICE, UNDERCURRENT OR UNDERPOWER RELAY, BEARING PROTECTIVE DEVICE, MECHANICAL CONDITION MONITOR, FIELD RELAY, FIELD CIRCUIT BREAKER, RUNNING CIRCUIT BREAKER, MANUAL TRANSFER OR SELECTOR DEVICE, UNIT SEQUENCE STARTING RELAY, ABNORMAL ATMOSPHERIC CONDITION MONITOR, REVERSE-PHASE OR BALANCE CURRENT RELAY, PHASE-BALANCE OR PHASE-SEQUENCE VOLTAGE RELAY, INCOMPLETE SEQUENCE RELAY, MACHINE OR TRANSFORMER THERMAL RELAY, INSTANTANEOUS OVERCURRENT RELAY, AC TIME OVERCURRENT RELAY, AC CIRCUIT BREAKER, FIELD EXCITATION RELAY, TURNING GEAR ENGAGING DEVICE, POWER FACTOR RELAY, FIELD APPLICATION RELAY, SHORT-CIRCUITING OR GROUNDING DEVICE, RECTIFICATION FAILURE RELAY, OVERVOLTAGE RELAY, VOLTAGE OR CURRENT BALANCE RELAY, DENSITY SWITCH OR SENSOR, TIME-DELAY STOPPING OR OPENING RELAY, PRESSURE SWITCH, GROUND DETECTOR RELAY, GOVERNOR, NOTCHING OR JOGGING DEVICE, AC DIRECTIONAL OVERCURRENT RELAY, BLOCKING OR OUT OF STEP RELAY, PERMISSIVE CONTROL DEVICE, RHEOSTAT, LIQUID LEVEL SWITCH, DC CIRCUIT BREAKER, LOAD-RESISTOR CONTACTOR, ALARM RELAY, POSITION CHANGING MECHANISM, DC OVERCURRENT RELAY, TELEMETRY DEVICE, PHASE-ANGLE MEASURING RELAY, AC RECLOSING RELAY, FLOW SWITCH, FREQUENCY RELAY, DC LOAD MEASURING RECLOSING RELAY, 83 AUTOMATIC SELECTIVE CONTROL OR TRANSFER RELAY, 84 OPERATING MECHANISM, 85 PILOT COMMUNICATIONS, CARRIER OR PILOT-WIRE RELAY, 86 LOCKOUT RELAY, 87 DIFFERENTIAL PROTECTIVE RELAY, 88 AUXILIARY MOTOR OR MOTOR GENERATOR, 89 LINE SWITCH, 90 REGULATING DEVICE, 91 VOLTAGE DIRECTIONAL RELAY, 92 VOLTAGE AND POWER DIRECTIONAL RELAY, 93 FIELD-CHANGING CONTACTOR, 94 TRIPPING OR TRIP-FREE RELAY

COMMONLY USED SUFFIX LETTERS APPLIED TO POWER DEVICE FUNCTION NUMBERS

Table of commonly used suffix letters: A ALARM ONLY, B BUS PROTECTION, G GROUND FAULT PROTECTION, GS GROUND FAULT PROTECTION (RELAY CT IN TOROIDAL OR GROUND SENSOR TYPE), L LINE PROTECTION, M MOTOR PROTECTION, N GROUND FAULT PROTECTION (RELAY COIL CONNECTED IN RESIDUAL CT CIRCUIT), T TRANSFORMER PROTECTION, V VOLTAGE, P PHASE PROTECTION

ABBREVIATIONS

Table of abbreviations: AFD - ARC FLASH DETECTOR, CLK - CLOCK OR TIMING SOURCE, DDR - DYNAMIC DISTURBANCE RECORDER, DFR - DIGITAL FAULT RECORDER, ENV - ENVIRONMENTAL DATA, HIZ - HIGH IMPEDANCE FAULT DETECTOR, HMI - HUMAN MACHINE INTERFACE, HST - HISTORIAN, LGC - SCHEME LOGIC, MET - SUBSTATION METERING, PDC - PHASOR DATA CONCENTRATOR, PMU - PHASOR MEASUREMENT UNIT, PQM - POWER QUALITY MONITOR, RIO - REMOTE I/O DEVICE, RTU - REMOTE TELEMETRY UNIT/REMOTE TERMINAL UNIT, SER - SEQUENCE OF EVENTS RECORDER, TCM - TRIP CIRCUIT MONITOR

Price Request Update December 2019

NOTES: 1. REFER TO SPECIFICATIONS AND OTHER DRAWINGS FOR ADDITIONAL ABBREVIATIONS.

CONTRACT NO. XXXXXX

VERIFY SCALES BAR IS ONE INCH ON ORIGINAL DRAWING PRELIMINARY DESIGN SUBMITTAL NOT FOR CONSTRUCTION



Table with columns for Date, Revision, and By

CITY OF SANTA ROSA LAGUNA TREATMENT PLANT ULTRAVIOLET (UV) LIGHT DISINFECTION EQUIPMENT SYSTEM ELECTRICAL ABBREVIATIONS

Date: SEPTEMBER 2016 Scale: AS SHOWN APPROVED: Deputy Director - Engineering By: Date: DWN LP DATE: 5-1-16 Drw No. GE02 File Number: 2016-0018

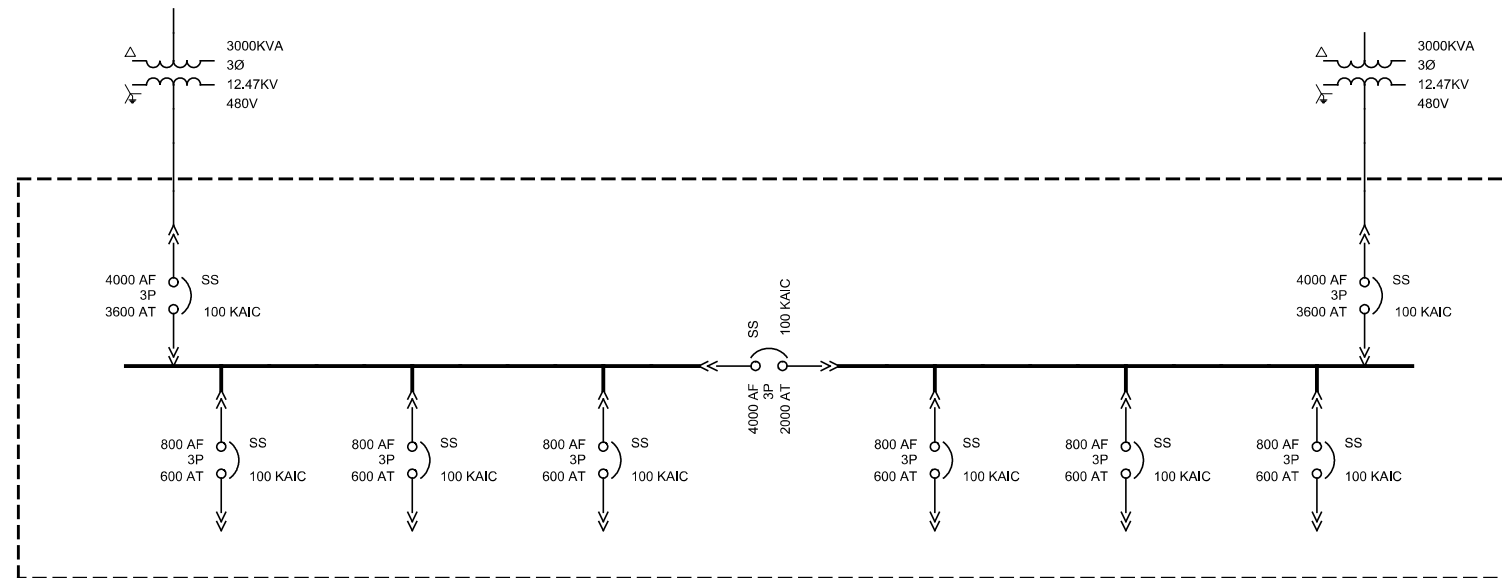

**Price
Request
Update
December
2019**

VERIFY SCALES
 BAR IS ONE INCH ON ORIGINAL DRAWING
 0 1"
 IF NOT ONE INCH ON THIS SHEET, ADJUST SCALES ACCORDINGLY

**PRELIMINARY DESIGN
 SUBMITTAL
 NOT FOR CONSTRUCTION**



Date	Revision	By

CITY OF SANTA ROSA
LAGUNA TREATMENT PLANT
 ULTRAVIOLET (UV) LIGHT DISINFECTION
 EQUIPMENT SYSTEM
UV SYSTEM SWITCHGEAR
ONE-LINE DIAGRAM

Date: <u>SEPTEMBER 2016</u> Scale: <u>AS SHOWN</u>	
APPROVED: Deputy Director - Engineering	
By: _____ Date: _____	
DWN <u>MNH</u> DATE: _____	Drw No. <u>E01</u> File Number: _____
CHK <u>CAC</u> DATE: 5-1-16	Sheet <u>15</u> of 28
DES <u>BS</u> DATE: 5-1-16	<u>2016-0018</u>

CONTRACT NO. XXXXXX

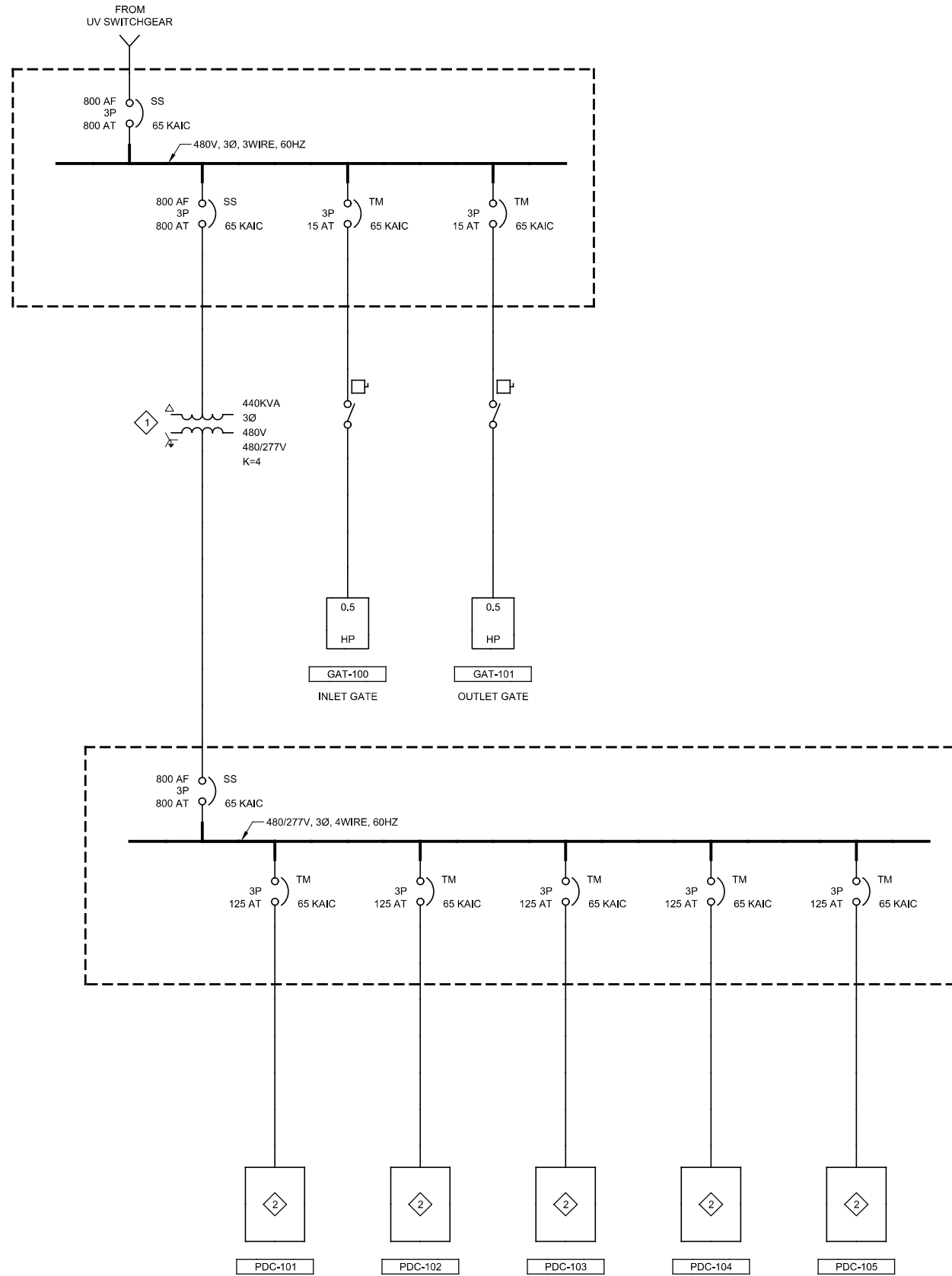

GENERAL NOTES:

1. 1 OUT OF 6 CHANNELS SHOWN.
2. 2 POWER DISTRIBUTION CENTER (PDCs) PER CHANNEL.
3. EACH PDC POWERS 288 UV LAMPS (4 UV BANKS).
4. PDC POWER CONSUMPTION IS 120.5 KVA.
5. SUPPLY TO PDC IS 230/133 VAC, 3Ø, 4W (+GND), 60HZ.
6. EACH PDC ALSO REQUIRES 120 VAC, 1 PH, 20 A SUPPLY.

KEY NOTES:

- 1 K. FACTOR TRANSFORMER WITH K-FACTOR = 4.
- 2 FURNISHED BY THE UV SYSTEM SUPPLIER.

Price
Request
Update
December
2019

VERIFY SCALES
BAR IS ONE INCH ON ORIGINAL DRAWING
0 1"
IF NOT ONE INCH ON THIS SHEET, ADJUST SCALES ACCORDINGLY

**PRELIMINARY DESIGN
SUBMITTAL
NOT FOR CONSTRUCTION**



Date	Revision	By

CITY OF SANTA ROSA
LAGUNA TREATMENT PLANT
ULTRAVIOLET (UV) LIGHT DISINFECTION
EQUIPMENT SYSTEM
CALGON CARBON C⁵500D
ONE-LINE DIAGRAM

Date: <u>SEPTEMBER 2016</u> Scale: <u>AS SHOWN</u>		CONTRACT NO. XXXXXX	
APPROVED: Deputy Director – Engineering			
By _____ Date _____			
DWN <u>MNH</u> DATE: _____	Drw No. <u>E04</u>	File Number: _____	
CHK <u>CAC</u> DATE: 5-1-16	Sheet <u>18</u> of <u>28</u>	<u>2016-0018</u>	
DES <u>BS</u> DATE: 5-1-16			

SYMBOL	DRAWING VISIBLE FIELDS	FIELD - 1	FIELD - 2	FIELD - 3	FIELD - 4	FIELD - 5	FIELD - 6
SCADA SYSTEM OPERATOR INTERFACE TERMINAL	1- TAG 2- LOOP NUMBER 3- FUNCTION 4- DESCRIPTION 5- DESCRIPTION 6- EXISTING/FUTURE	REFER	REFER	ACTION ALARM NUM - NUMERIC SP - SET POINT STATUS TREND	DESCRIPTION	DESCRIPTION	E - EXISTING F - FUTURE
HARDWIRED I/O POINT	1- TAG 2- LOOP NUMBER 3- FUNCTION 4- DESCRIPTION 5- LOCATION 6- EXISTING/FUTURE	REFER	REFER	AI - ANALOG INPUT AO - ANALOG OUTPUT DI - DISCRETE INPUT DO - DISCRETE OUTPUT HSC - HIGH SPEED COUNTER INPUT RTD - RTD INPUT	DESCRIPTION	PAC - PROGRAMMABLE AUTOMATION CONTROLLER NO. PLC - PROGRAMMABLE LOGIC CONTROLLER NO. RIO - REMOTE I/O VCP - VENDOR CONTROL PANEL NO.	E - EXISTING F - FUTURE
DIGITAL BUS I/O REGISTER (FIELDBUS I/O)	1- TAG 2- LOOP NUMBER 3- FUNCTION 4- DESCRIPTION 5- LOCATION 6- EXISTING/FUTURE	REFER	REFER	BUS ID CNET - CONTROLNET DNET - DEVICENET ENET - ETHERNET/IP FF - FOUNDATION FIELDBUS MB - MODBUS RTU MB+ - MODBUS PLUS MBTCP - MODBUS TCP DP - PROFIBUS DP PA - PROFIBUS PA PNET - PROFINET SERIAL - PROPRIETARY PROTOCOL	DESCRIPTION	PAC - PROGRAMMABLE AUTOMATION CONTROLLER NO. PLC - PROGRAMMABLE LOGIC CONTROLLER NO. RIO - REMOTE I/O VCP - VENDOR CONTROL PANEL NO.	E - EXISTING F - FUTURE
HUMAN MACHINE INTERFACE	1- TAG 2- LOOP NUMBER 3- FUNCTION 4- DESCRIPTION 5- LOCATION 6- EXISTING/FUTURE	REFER	REFER	ACTION ALARM NUM - NUMERIC SP - SET POINT STATUS	DESCRIPTION	HMI - HUMAN MACHINE INTERFACE NO. LCP - LOCAL CONTROL PANEL NO. PCM - PROCESS CONTROL MODULE NO. VCP - VENDOR CONTROL PANEL NO.	E - EXISTING F - FUTURE
PILOT DEVICE OPERATOR INTERFACE	1- TAG 2- LOOP NUMBER 3- FUNCTION 4- DESCRIPTION 5- LOCATION 6- EXISTING/FUTURE	REFER	REFER	AM - AUTO/MANUAL BYPASS - BYPASS CL - CLOSE E-STOP - EMERGENCY STOP FRLR - FIXED RATE/LEVEL RATE HOA - HAND /OFF/AUTO JOHC - JOG OPEN/HOLD/CLOSE JOJC - JOG OPEN/JOG CLOSE LH - LOW/HIGH LOR - LOCAL/OFF/REMOTE LOS - LOCK OUT STOP LS - LEAD/STANDBY LSR - LOCAL/STOP/REMOTE NOOT - NO OFFLINE/OFFLINE TRANSITION OC - OPEN/CLOSE OLOL - ON LINE/OFF LINE OO - OFF/ON OP - OPEN OSC - OPEN/STOP/CLOSE RST - RESET SAAM - SEMI AUTO/AUTO/MANUAL SEL - SELECT SP - STOP SPD - SPEED SS - START/STOP ST - START	DESCRIPTION	LCP - LOCAL CONTROL PANEL NO. MCC - MOTOR CONTROL CENTER NO. PCM - PROCESS CONTROL MODULE NO. RVSS - REDUCED VOLTAGE SOLID STARTER NO. VCP - VENDOR CONTROL PANEL NO. VFD - VARIABLE FREQUENCY DRIVE NO.	E - EXISTING F - FUTURE
POWER DEVICE PRIMARY FUNCTION OPERATOR ACCESSIBLE	1- TAG 2- LOOP NUMBER 3- FUNCTION 4- VOLTAGE/PHASE 5- LOCATION 6- EXISTING/FUTURE	CB - CIRCUIT BREAKER DISC - DISCONNECT FU - FUSE	REFER	TM - THERMAL MAGNETIC CIRCUIT BREAKER	24VDC - 1P 120VAC - 1P 208VAC - 2P 208VAC - 3P 240VAC - 3P 240VAC - 2P 480VAC - 3P 2400VAC - 3P 4160VAC - 3P	DP - DISTRIBUTION PANEL NO. LCP - LOCAL CONTROL PANEL NO. LP - LIGHTING PANEL NO. MCC - MOTOR CONTROL CENTER NO. PCM - PROCESS CONTROL MODULE NO. PP - POWER PANEL NO. VCP - VENDOR CONTROL PANEL NO.	E - EXISTING F - FUTURE
POWER DEVICE AUXILIARY FUNCTION FOR OPERATOR ACCESSIBLE DEVICES	1- TAG 2- LOOP NUMBER 3- DESCRIPTION 4- DESCRIPTION 5- DESCRIPTION 6- EXISTING/FUTURE	DISC - DISCONNECT	REFER	DESCRIPTION	DESCRIPTION	DESCRIPTION	E - EXISTING F - FUTURE
POWER DEVICE PRIMARY FUNCTION OPERATOR INACCESSIBLE	1- TAG 2- LOOP NUMBER 3- FUNCTION 4- VOLTAGE/PHASE 5- LOCATION 6- EXISTING/FUTURE	CB - CIRCUIT BREAKER FU - FUSE	REFER	MCP - MOTOR CIRCUIT PROTECTOR SS - SOLID STATE CIRCUIT BREAKER TM - THERMAL MAGNETIC CIRCUIT BREAKER	24VDC - 1P 120VAC - 1P 208VAC - 2P 208VAC - 3P 240VAC - 2P 240VAC - 3P 480VAC - 3P 2400VAC - 3P 4160VAC - 3P	DP - DISTRIBUTION PANEL NO. LCP - LOCAL CONTROL PANEL NO. LP - LIGHTING PANEL NO. MCC - MOTOR CONTROL CENTER NO. PCM - PROCESS CONTROL MODULE NO. PP - POWER PANEL NO. VCP - VENDOR CONTROL PANEL NO.	E - EXISTING F - FUTURE

INSTRUMENT BUBBLE LOCATIONS		NOTES
SCADA		<p>1 INSTRUMENT TAG IDENTIFICATION LETTERS TABLE</p> <p>2 OPERATOR PILOT DEVICE LEGEND</p> <p>3 EQUIPMENT TAGGING TABLE</p> <p>4 I/O TYPE DESIGNATIONS TABLE</p> <p>5 INSTRUMENT TYPE DESIGNATIONS TABLE</p> <p>6 FURNISHED BY: FBO FURNISHED BY OWNER FBV FURNISHED BY VENDOR</p> <p style="color: red; font-weight: bold; border: 1px solid red; padding: 5px;">Price Request Update December 2019</p>
CONTROL PANEL		
OPERATOR INTERFACE/INTERFACES/DEVICES		
POWER SOURCE		
FIELD		

VERIFY SCALES

BAR IS ONE INCH ON ORIGINAL DRAWING

0 1"

IF NOT ONE INCH ON THIS SHEET, ADJUST SCALES ACCORDINGLY

PRELIMINARY DESIGN SUBMITTAL NOT FOR CONSTRUCTION



Date	Revision	By

CONTRACT NO. XXXXXX

CITY OF SANTA ROSA

LAGUNA TREATMENT PLANT ULTRAVIOLET (UV) LIGHT DISINFECTION EQUIPMENT SYSTEM

INSTRUMENTATION SYMBOLS & ABBREVIATIONS - I

Date: SEPTEMBER 2016 Scale: AS SHOWN

APPROVED: Deputy Director - Engineering

By: _____ Date: _____

DWN LP DATE: _____
CHK CAC DATE: 5-1-16
DES BS DATE: 5-1-16

Drw No. GN01
Sheet 20 of 28

File Number: 2016-0018

INSTRUMENT TAG IDENTIFICATION LETTERS

Table with columns for Measured Variable, Instrument Function, and various tag letters (AE, AT, AIT, etc.) corresponding to different process variables like ANALYSIS, FLOW, TEMPERATURE, etc.

* REFER TO OPERATOR PILOT DEVICE LEGEND
** LETTER INDICATES POSITION (O=OPEN, C=CLOSED, R=RAISE, L=LOWER, ETC)
*** PI# # = 1,2,3 ETC. AND REPRESENTS A UNIQUE IDENTIFIER AND IS APPLICABLE TO ALL ITEMS IN THE TABLE ABOVE
**** COULD ALSO BE PIS - FOR PRESSURE INDICATING SWITCH

OPERATOR PILOT DEVICE LEGEND

Table mapping Pilot Device Function (e.g., STOP, START, SELECT) to Device Type and corresponding Tag Letters (HSA, HSB, HSC, etc.).

HSA* SELECTOR SWITCH POSITION EG: HSA(R) R = REMOTE, HSD(A) A = AUTO, ETC

I/O TYPE DESIGNATIONS

Table listing I/O type designations such as RUNNING, FAILED/FAULT, RUNNING FORWARD, etc., with their corresponding tag letters.

INSTRUMENT TYPE DESIGNATIONS

Table listing instrument type designations such as AMMONIA, CAPACITANCE, COMBUSTIBLE GAS, etc., with their corresponding tag letters.

SPECIFIC ABBREVIATIONS

Table listing specific abbreviations such as A PHASE, B PHASE, BEARING BOTTOM, etc., with their corresponding tag letters.

* CC# AND SV# # = 1, 2, 3 ETC. AND REPRESENTS A UNIQUE IDENTIFIER

INSTRUMENT LINE SYMBOLS

Table showing instrument line symbols for various types: PNEUMATIC SIGNAL, ELECTRIC SIGNAL, HYDRAULIC SIGNAL, etc., with their corresponding graphical representations.

PROCESS LINE SYMBOLS

Table showing process line symbols for primary and secondary process flow in pipes and channels.

DESIGNATIONS

Table showing designations for equipment enclosure, existing, and future states.

MISCELLANEOUS P&ID SYMBOLS

Table showing miscellaneous P&ID symbols such as CHEMICAL INJECTION POINT, CONTINUATION TAG, PIPE CALLOUT, and SIGNAL CONTINUATION.

Price Request Update December 2019

VERIFY SCALES
BAR IS ONE INCH ON ORIGINAL DRAWING
IF NOT ONE INCH ON THIS SHEET, ADJUST SCALES ACCORDINGLY

PRELIMINARY DESIGN SUBMITTAL NOT FOR CONSTRUCTION



CITY OF SANTA ROSA
LAGUNA TREATMENT PLANT ULTRAVIOLET (UV) LIGHT DISINFECTION EQUIPMENT SYSTEM
INSTRUMENTATION SYMBOLS & ABBREVIATIONS - II
Date: SEPTEMBER 2016
Scale: AS SHOWN
APPROVED: Deputy Director - Engineering
By: _____ Date: _____
DWN LP DATE: _____
CHK CAC DATE: 5-1-16
DES BS DATE: 5-1-16
Drw No. GN02
Sheet 21 of 28
File Number: 2016-0018

ACTUATORS

- DIAPHRAGM
- ELECTRIC DISCRETE
- ELECTRIC MODULATING
- ELECTRIC HYDRAULIC
- HAND
- HYDRAULIC
- PNEUMATIC
- SOLENOID

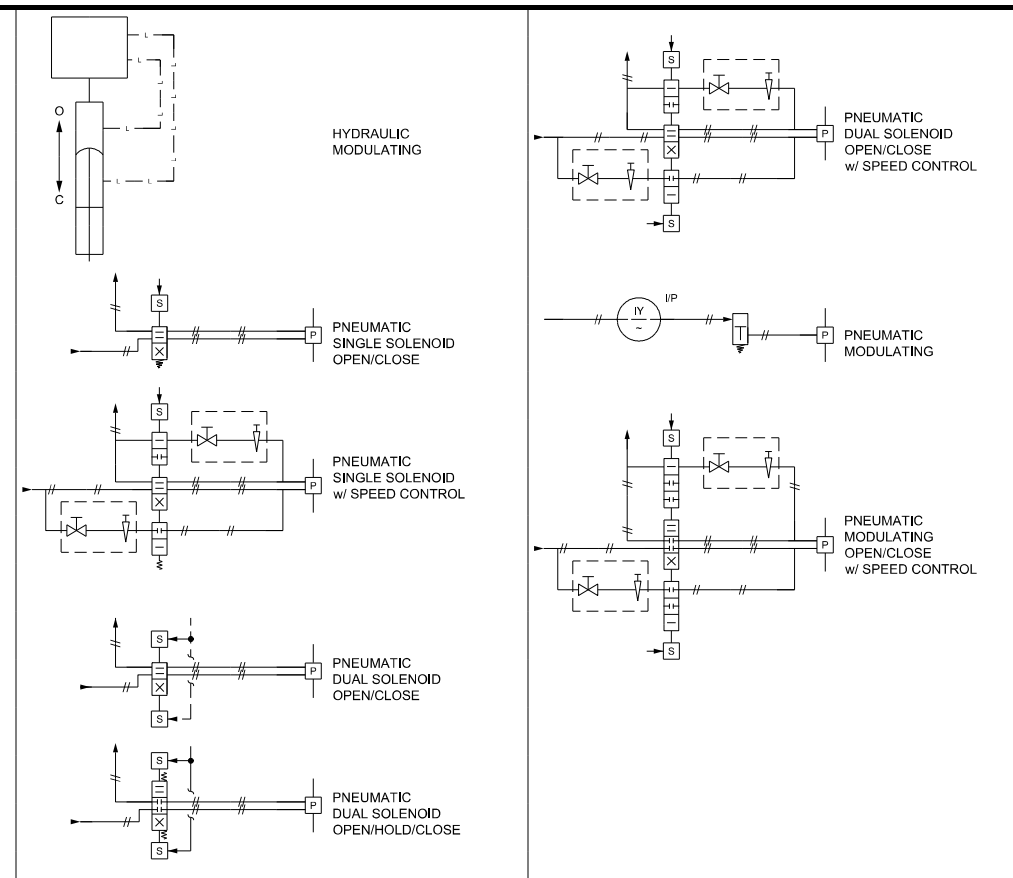

PIPING

- AIR GAP
- BLIND FLANGE
- CAPPED OR PLUGGED
- CONCENTRIC INCREASER
- CONCENTRIC REDUCER
- DRAIN
- ECCENTRIC INCREASER
- ECCENTRIC REDUCER
- EXPANSION COUPLING
- EXPANSION JOINT VIBRATION CENTER
- FLEXIBLE CONNECTION
- QUICK DISCONNECT

- TEE
- UNION

PUMPS

- AIR DRIVEN
- CENTRIFUGAL
- CHEMICAL FEED DIAPHRAGM
- DIAPHRAGM
- GEAR
- PERISTALTIC OR HOSE
- PISTON
- PROGRESSIVE CAVITY
- SUBMERSIBLE
- VERTICAL TURBINE
- VERTICAL CHOPPER
- WATER CHAMP

BLOWERS/COMPRESSORS

- CENTRIFUGAL SINGLE STAGE BLOWER
- CENTRIFUGAL MULTI STAGE BLOWER
- RECIPROCATING COMPRESSOR
- SCREW COMPRESSOR
- FAN
- LIQUID RING COMPRESSOR
- ROTARY LOBE BLOWER

MISC

- AIR DAMPER
- AIR/CHEMICAL DIFFUSER
- BASKET STRAINER
- BLOW-OFF SILENCER
- CALIBRATION COLUMN
- COALESCKER
- DESICCANT DRYER
- EDUCTOR/EJECTOR
- EYEWASH
- EXHAUST FAN
- FILTER
- FILTER SEPARATOR
- FINE FILTER
- FIRE ALARM/SENSOR
- FLAME ARRESTER
- FLAME ARRESTER W/THERMALLY OPERATED VALVE
- FLOW CONDITIONER
- GAS CANNON
- GRINDER
- HEAT EXCHANGER
- HOIST
- HORIZONTAL MIXER
- HOSE CONNECTION
- INLET STRAINER
- INLINE STATIC MIXER
- MATERIAL CHANGE
- MIXER
- MOTOR
- NOZZLE
- ORIFICE RESTRICTION
- PERISTALTIC COMPOSITE SAMPLER
- PULSATION DAMPENOR
- REFRIGERATED DRYER
- RUPTURE DISK
- SAMPLE PORT
- SIGHT TUBE
- SMOKE DETECTOR
- STRAINER - MECHANICALLY CLEANED
- STRAINER WITH BLOW OFF
- STRAINER WYE TYPE
- VAPOR HEATER
- VAPORIZER
- VENT
- VENT TO ATMOSPHERE

CHECK VALVES

- BACK FLOW PREVENTOR
- BALL
- DIAPHRAGM CHECK
- DOUBLE FLAP
- FLAPPER
- SPRING LOADED GENERAL
- SPRING LOADED SWING
- SWING

PRESSURE VALVES

- BACKPRESSURE REGULATING SELF CONTAINED
- BACKPRESSURE REGULATING EXTERNAL TAP
- PRESSURE REDUCING SELF CONTAINED
- PRESSURE REDUCING EXTERNAL PRESSURE TAP
- REGULATING
- PRESSURE RELIEF
- VACUUM RELIEF

VALVES

- 3-WAY
- 3-WAY PLUG
- 4-WAY
- AIR-RELIEF
- ANGLE
- BALL
- BALL V-NOTCH
- BUTTERFLY
- BUTTERFLY-BURIED VALVE BOX
- CONE
- DIAPHRAGM
- GATE
- GATE-BURIED VALVE BOX
- GLOBE
- HOSE
- MUD
- NEEDLE
- PINCH
- PLUG ECCENTRIC
- PLUG ECCENTRIC w-VALVE BOX
- PLUG ECCENTRIC LUBRICATED
- PLUG ECCENTRIC LUBRICATED BURIED VALVE BOX
- PLUG CONCENTRIC
- PLUG CONCENTRIC BURIED VALVE BOX
- PLUG CONCENTRIC LUBRICATED
- PLUG CONCENTRIC LUBRICATED BURIED VALVE BOX
- PUMP DISCHARGE
- TELESCOPING

VALVE DESIGNATIONS	
NO	NORMALLY OPEN
NC	NORMALLY CLOSED
FO	FAIL OPEN
FC	FAIL CLOSE
FLP	FAIL LAST POSITION

Price Request Update December 2019

VERIFY SCALES

BAR IS ONE INCH ON ORIGINAL DRAWING

IF NOT ONE INCH ON THIS SHEET, ADJUST SCALES ACCORDINGLY

PRELIMINARY DESIGN SUBMITTAL NOT FOR CONSTRUCTION

IN ASSOCIATION WITH

CITY OF SANTA ROSA

LAGUNA TREATMENT PLANT ULTRAVIOLET (UV) LIGHT DISINFECTION EQUIPMENT SYSTEM

INSTRUMENTATION SYMBOLS & ABBREVIATIONS - III

CONTRACT NO. XXXXXX

Date: SEPTEMBER 2016 Scale: AS SHOWN

APPROVED: Deputy Director - Engineering

By: _____ Date: _____

DWN LP DATE: _____ Drw No. GN03 File Number: _____

CHK CAC DATE: 5-1-16 Sheet 22 of 28 2016-0018

DES BS DATE: 5-1-16

Date	Revision	By

Price Request Update December 2019

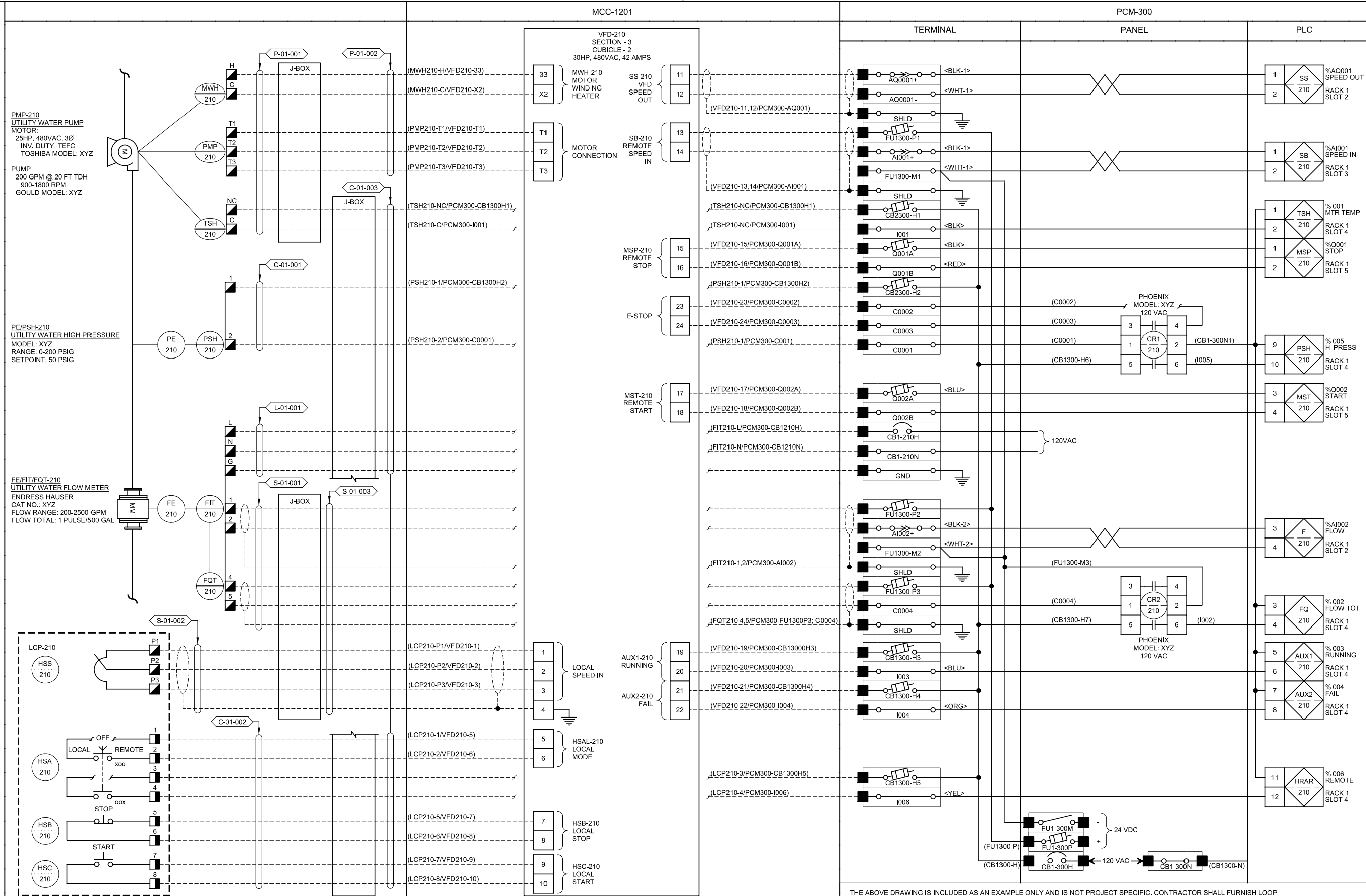

THE ABOVE DRAWING IS INCLUDED AS AN EXAMPLE ONLY AND IS NOT PROJECT SPECIFIC. CONTRACTOR SHALL FURNISH LOOP DIAGRAMS FOR THE ENTIRE FACILITY. PRELIMINARY DETAILED LOOP DIAGRAMS TO BE SUBMITTED FOR REVIEW PRIOR TO BEGINNING CONSTRUCTION. THE LOOP DIAGRAM SHOWN ABOVE DISPLAYS THE LEVEL OF EXPECTED DETAIL.

CONTRACT NO. XXXXXX

VERIFY SCALES
 BAR IS ONE INCH ON ORIGINAL DRAWING
 0 1"

 IF NOT ONE INCH ON THIS SHEET, ADJUST SCALES ACCORDINGLY

PRELIMINARY DESIGN SUBMITTAL NOT FOR CONSTRUCTION



Date	Revision	By

CITY OF SANTA ROSA
LAGUNA TREATMENT PLANT
ULTRAVIOLET (UV) LIGHT DISINFECTION
EQUIPMENT SYSTEM

INSTRUMENTATION
SAMPLE LOOP DRAWING

Date: SEPTEMBER 2016 Scale: AS SHOWN
 APPROVED: Deputy Director - Engineering
 By: _____ Date: _____
 DWN LP DATE: _____
 CHK CAC DATE: 5-1-16
 DES BS DATE: 5-1-16
 Drw No. GN05 File Number: 2016-0018
 Sheet 24 of 28



EXHIBIT B1

EXECUTIVE SUMMARY

Proposal # 00001170

Revision: 5

Santa Rosa LTP, CA - C3500D UV Disinfection System

Calgon Carbon proposes to supply our C3500D Ultraviolet Disinfection System to treat effluent at the above site. This system will include 2600 UV lamps to treat the peak flow of 70 MGD. The system will be configured into 5 channels, 5 banks per channel, 13 racks per bank each with 8 lamps. One bank per channel is provided for redundancy.

The main advantages of the C3500D system are as follows:

- The C3500D uses the highest power low pressure horizontal lamps available. The UV lamp emits 204 W of UV light at 254 nm. This means our system will have fewer lamps, resulting in less maintenance.
- The C³500D system includes automatic, in-place cleaning as a key feature. This reduces the need for operators to remove lamp racks and manually clean them, significantly reducing maintenance. The Calgon Carbon automatic cleaner is mechanical only – no chemicals are required.
- The patented mixing devices dramatically improve the hydraulic and germicidal efficiency of the UV reactor providing unparalleled performance.

Calgon Carbon is a world leader in granular activated carbon solutions. We are also one of the world's foremost providers of ultraviolet light (UV) disinfection and oxidation technologies for water. From the initial introduction of our UV advanced oxidation systems to the continued development of drinking water and wastewater disinfection technologies, we've been delivering proven UV water treatment solutions for more than 25 years. Combined we have over 500 installations in operation or under construction.

This proposal includes system sizing and a bill of materials. If you need any further information, please feel free to contact David DesRochers at 519.824.8318.



PROJECT SPECIFICATIONS

Proposal # 00001170

Revision: 5

Santa Rosa LTP, CA - C3500D UV Disinfection System

1. Design Conditions

Peak Flow	70	MGD
Average Flow	20	MGD
Minimum UV Transmittance	61 %	
Average UV Transmittance	64 %	
Total Suspended Solids	5 mg/L	
Total Coliform Permit Limit	2.2 CFU/100mL, based on 7-day median	
Poliovirus Reduction	5-log	

2. C³500D Specifications

Lamp UV Radiation at 254 nm	204	
Lamp Life	16,000 Hours	
Lamp Life Factor	0.85	
Quartz Transmission Factor	0.92	
Quartz Fouling Factor	0.90	
MS2 T22 RED	100.1 mJ/cm2 validated	

3. System Configuration

Number of Channels	5	
Number of Banks/Channel	5	One bank is provided for redundancy
Number of Racks/Bank	13	
Number of Lamps/Rack	8	
Total Number of Lamps	2600	
Number of UV Sensors	25	
Number of Power Distribution Centers	25	
Number of Master System Control Centers	1	
Number of Channel System Control Centers	5	
Number of Weirs	5	

4. Hydraulic Considerations

Peak Velocity in Channel	10 inches/s	
Headloss per UV Bank	0.39 inches	
Total Headloss across UV System	1.94 inches (not including Level Controller)	
Retention Time	21.12 seconds	

5. Electrical Requirements

Input Voltage	480/277 VAC, 3Ph, 4-wire	
Peak Loading per PDC	84.4 FLA	
Power Consumption per PDC	60.3 kW (all lamps at 100% power)	
Total System Power Consumption	1507.6 kW (all lamps at 100% power)	

6. Approximate Channel Dimensions

Length	850 inches	
Width	78 inches	
Width at Level Control Weir	78 inches	
Channel Height	72 inches	
Channel Height at Level Control Weir	72 inches	
Effluent Depth in Channel	48 inches, nominal	



BILL OF MATERIALS

Proposal # 00001170

Revision: 5

Santa Rosa LTP, CA - C3500D UV Disinfection System

Item No.	Qty.	Model Number C3500D5513081WP
1.	5	Channel Equipment
	Qty. 1	Level Control Weir
	Qty. 5	Integrated Bank Assembly, 316L SS
	Qty. 20	Bank Guides, 304 SS
	Qty. 2	Point Ultrasonic Level Sensor with Mounting Bracket
	Qty. 5	UV Sensors with Mounting Bracket and Scrapers
	Qty. 3	Level Sensor with Mounting Bracket (Capacitance Probe)
	Qty. 2	Stilling Plate with Mounting Brackets, 316L SS
2.	325	Lamp Rack Assemblies, 316L/304L SS
	Qty. 8	Low Pressure High Intensity Amalgam Lamps
	Qty. 8	Quartz Sleeves
	Qty. 2	Cable Assemblies
	Qty. 1	Cleaning System Motor
	Qty. Lot	Cleaning System Mechanism and Accessories
	Qty. 8	Scrapers
3.	25	Power Distribution Centers, 304 SS, NEMA 4X
	Qty. 104	Electronic Ballasts
	Qty. 1	Main Breaker
	Qty. 13	Earth Leakage Circuit Breakers
	Qty. Lot	Control & Monitoring Equipment with Operator Station
4.	1	Master System Control Center, Mild Painted Steel, NEMA 12, Wall Mount with Floor Stand
	Qty. 1	Main Breaker
	Qty. Lot	Siemens S7 PLC Equipment and Accessories
	Qty. 1	Siemens TP 1500 Operator Interface
5.	1	Channel System Control Center, Mild Painted Steel, NEMA 12, Wall Mount with Floor Stand
	Qty. 1	Main Breaker
	Qty. Lot	Siemens S7 PLC Equipment and Accessories
6.	Lot	Spare Parts
	Qty. 4	UV Face Shield
	Qty. 130	Electronic Ballasts
	Qty. 260	UV Lamps
	Qty. 260	Quartz Sleeves
	Qty. 260	Lamp End Seals
	Qty. 260	Scraper Assemblies
	Qty. 3	UV Intensity Sensor Assembly



7.	Lot	Accessories
	Qty. 1	Mercury Spill Kit
	Qty. 2	Service Trolley, 304 SS
	Qty. 2	Rack Lifting Sling, 304 SS
	Qty. 2	Lifting Sling for Integrated Bank Assembly, 304 SS
	Qty. 1	RealTech UV Photometer, Model No. UVT-254 P200
	Qty. 1	HACH On-line UV Transmission Analyzer
	Qty. 1	Reference UV Sensor
	Qty. 2	Greenlee LT100 Lamp Testers
	Qty. 130	Lamp Plugs
	Qty. 2	Calgon Carbon Control Card
	Qty. 17	Calgon Carbon Backplane Board
	Qty. 17	Calgon Carbon Ballast Control Module
	Qty. 1	Calgon Carbon Motor Control Module
	Qty. 5	Fans
	Qty. 1	PLC CPU
	Qty. 2	PLC Analog Input Module
	Qty. 2	PLC Digital Input Module
	Qty. 2	PLC Digital Output Module
	Qty. 2	PLC Power Supply
	Qty. 1	PLC RS485 Communication Card
	Qty. 1	Lot of Fuses (qty. 5 spare fuses of each type)
	Qty. 1	Wooden Box for Spare Parts: 24" W x 18" H x 36" L
	Qty. 2	Chemical Cleaning Tank for 1 Bank, Qty. 13 Lamp Racks 84"W x 92"L - 304LSS Liner w/ 4" drain stub and FRP cover
8.	Lot	Equipment Documentation
9.	Lot	Start-up and Commissioning Services
10.		Two (2) Years Warranty Period

Terms and Conditions

Payment Terms: CCUV Standard Terms
 Freight: D.A.P. Jobsite
 Delivery: 20 to 24 weeks after receipt of approved shop drawings

CCUV Standard Terms & Conditions Will Apply

Budgetary Price (USD): \$5,634,700

EXHIBIT B2

DOCUMENT 00410
PROPOSAL FORM
BEST AND FINAL OFFER
DECEMBER 2021

PROJECT IDENTIFICATION:

City of Santa Rosa
Ultraviolet (UV) Light Disinfection Equipment System
Proposal Number 16-71

THIS UPDATED PROPOSAL IS SUBMITTED IN THE FORM OF A BEST AND FINAL OFFER
BY:

De Nora UV Technologies, LLC

(Supplier)

2000 McLaren Woods Drive, Coraopolis, Pennsylvania, 15108

(Supplier Address)

THIS UPDATED PROPOSAL IS SUBMITTED IN THE FORM OF A BEST AND FINAL OFFER
TO:

JASON ROBERTS, PE
SUPERVISING ENGINEER

CITY OF SANTA ROSA TRANSPORTATION AND PUBLIC WORKS DEPARTMENT

69 STONY CIRCLE
SANTA ROSA, CA 95401
707-543-3857 VOICE
JROBERTS@SRCITY.ORG

- 1.01 The undersigned Supplier proposes and agrees to enter into a Memorandum of Understanding with CITY in the form included in the Procurement Documents to perform and furnish all Goods and Services as specified or indicated in the Procurement Documents within the specified time and for the amount indicated in this Bid and in accordance with the other terms and conditions of the Procurement Documents.

ARTICLE 2 - SUPPLIER'S ACKNOWLEDGMENT

- 2.01 Supplier accepts all of the terms and conditions of the RFP. Supplier will execute and submit the Memorandum of Understanding and other attachments as required by the Procurement Documents and as provided in CITY's Notice of Selection, Second Amended and Restated MOU, which sets pricing through December 31, 2022.

ARTICLE 3 - SUPPLIER'S REPRESENTATIONS

- 3.01 In submitting this Bid, the Supplier represents that:
- A. Supplier has examined copies of all the Procurement Documents and of the following Addenda (receipt of all which is hereby acknowledged):

ADDENDA

No. <u> 1 </u>	Dated <u>October 10, 2016</u>
No. <u> 2 </u>	Dated <u>December 24, 2019</u>
No. _____	Dated _____
No. _____	Dated _____
No. _____	Dated _____

- B. Supplier is familiar with and has satisfied itself as to all federal, state, and local laws and regulations that may affect cost, progress, performance, and furnishing of the equipment and the Work described herein including but not limited to the requirements in the Technical Specifications and Title 22 of the California Code of Regulations.
- C. Supplier has given CITY written notice of all conflicts, errors, ambiguities, or discrepancies that Supplier has discovered in the Procurement Documents and the written resolution thereof by the CITY is acceptable to Supplier, and the Procurement Documents are generally sufficient to indicate and convey understanding of all terms and conditions for performing and furnishing the equipment and the Work identified on the Proposal.

ARTICLE 4 - BASIS OF PROPOSAL – BEST AND FINAL OFFER

4.01 Furnish the CITY with a complete UV Disinfection Systems per the attached general specifications, technical specifications and plans, and requirements. Indicate the make and model you are quoting and attach descriptive literature.

CITY OF SANTA ROSA, LAGUNA TREATMENT PLANT (LTP) PROPOSAL FORM		
Item No.	Description	Proposal Price (\$ US)
Equipment Costs		
1	UV Disinfection System, as specified in the Technical Specifications (sales and use taxes not included)	\$5,628,891.28
2	Spare parts and special tools, as specified in the Technical Specifications	\$132,300
3	Freight, as specified in the Technical Specifications	\$73,700
4	Supervision of installation, testing, training, commissioning, warranty, and Follow-up support services. (Technical Specifications Sections 11289 and 01756)	\$88,600
5	Total Equipment Cost (Sum of Items #1 - 4) (Sales and use taxes not included)	\$5,923,491.28 US
Operation and Maintenance Costs		
7	Annual Cost for Electricity: Item #7a multiplied by the unit power cost (\$0.10/kW-hr) multiplied by 365 days per year.	\$344,026
	a Average Power Consumption (APC) for all equipment supplied by Supplier, expressed in kilowatt-hours/day, for the average annual flow condition and average UV transmittance. ⁽¹⁾	9425.4
8	Annual lamp replacement costs: Item #8c multiplied by Item #8d.	\$103,958
	a Number of Lamps in Service at average annual flow rate of 20 mgd and average UV transmittance of 64 percent. Include a 25 percent safety factor. Use the design End of Lamp Life and Fouling factors when calculating the required number of lamps at average conditions. Then multiple the required number of lamps at average conditions by the safety factor (1.25) to determine the Number of Lamps in Service (Ad1).	780
	b Guaranteed Lamp Life, expressed in hours, for the conditions in Item #7a.	16,000
	c Number of Lamps Replaced Per Year: Item #7a divided by Item #7b multiplied by 8,760 hours in a year.	427.1
	d Lamp Material Cost: guaranteed not-to-exceed replacement cost for one (1) UV lamp, expressed in dollars.	\$243
9	Annual ballast replacement costs: Item #9a divided by Item #9c and then multiplied by Item #9b.	\$152,199
	a Total number of installed ballasts/lamp drivers.	2600
	b Guaranteed replacement cost per ballast/lamp drivers expressed in dollars.	\$585
	c Guaranteed Ballast/Lamp Driver Life, expressed in years.	10
10	Annual sleeve replacement costs: Item #10a divided by Item #10c and then multiplied by Item #10b.	\$17,999
	a Total number of installed quartz sleeves.	2600
	b Quartz Sleeve Replacement Cost: the guaranteed not-to- exceed replacement cost of one (1) quartz sleeve, expressed in dollars.	\$104
	c Guaranteed Quartz Sleeve Life, expressed in years.	15
11	Annual sensor replacement costs: Item #11a divided Item #11c and then multiplied by Item #11b.	\$4,286

CITY OF SANTA ROSA, LAGUNA TREATMENT PLANT (LTP) PROPOSAL FORM

Item No.	Description	Proposal Price (\$ US)
	a Total number of UV intensity sensors in the system.	25
	b UV Intensity Sensor Replacement Cost: the guaranteed not-to- exceed replacement cost of one (1) UV intensity sensor expressed in dollars.	\$1,200
	c Guaranteed Sensor Life, expressed in years.	7
12	Cost for duty/reference sensor calibration: Item #12b multiplied by Item #12c.	\$854
	a Total number of duty/reference sensors that require calibration.	26
	b Average number of calibrations required per year.	3.7
	c Average cost per calibration of sensors, expressed in dollars.	\$230
13	Annual cost for cleaning system consumables (Cleaning Solution, etc.)	\$0
14	Annual wiper replacement cost: Item #14a divided by Item #14c and then multiplied by Item #14b.	\$30,212
	a Total number of automatic cleaning wipers installed in the system. * <i>(* note quantity shown are installed in operating channels)</i>	780
	b Guaranteed replacement cost per wiper, expressed in dollars.	\$58
	c Guaranteed wiper life, expressed in years.	5
15	Total Annual Operational and Maintenance Cost (Sum of Items #7 - 14)	\$632,385 US
16	Total Operational and Maintenance cost over 20 years (Item #15 * 20 years)	\$12,647,701 US
17	TOTAL EQUIPMENT SUPPLY AND O&M BID (Sum of Item #5 and Item #16)	\$18,571,192.28 US

Options

Notes:

- (1) The Average Power Consumption (APC) calculation shall assume that the system will operate at conditions specified in Section 11289 of the Technical Specifications.
- (2) Value entered in Item #7 shall be equivalent to the value expected to be determined by validation testing divided by 0.80 (attenuated lamp conditions for APC calculations). This factor will be used for all manufactures for the life cycle cost analysis and is independent of the validated quartz sleeve fouling and lamp aging factors. Specific quartz sleeve fouling and lamp aging factors listed in Form 1 of Section 11289 in the Technical Specifications shall be used for sizing equipment.

4.02 Supplier further agrees that performance of Supplier field services (including installation check, startup assistance, and certification of acceptable installation and operation) to final completion will be coordinated with the Contractor to the satisfaction of the CITY.

4.03 Communications concerning this Proposal shall be sent to Supplier at the following address:

Kris Sticinski, Americas Sales Director

Email: kris.sticinski@denora.com

Tel: 424-392-1107

4.04 The terms used in this Proposal shall have the meanings assigned to them in Section 00200 included as part of the Procurement Documents.

SIGNATURE OF SUPPLIER

By: De Nora UV Technologies, LLC
(Company Name)

By: _____
(Signature of Authorized Person)

(Name)

(Title)

(Date)

Business address: 2000 McLaren Woods Drive, Coraopolis, Pennsylvania, 15108

Phone Number: 424-392-1107 FAX Number: 724-695-3318

END OF DOCUMENT

December 1, 2021

EXHIBIT C

City of Santa Rosa

Transportation & Public Works Department
Attn. Jason Roberts, Supervising Engineer
69 Stony Circle
Santa Rosa, CA 95401

Reference: Meeting October 6th/2021 Follow up and Best and Final Offer.

Dear Jason:

Per our conversation today please find attached supporting documentation on justification of our price increase. Outside of our control, there have been real cost impacts that were unforeseen at the time of signing the last MOU.

1. The cost impact of stainless steel. Over the last year, all primary components and materials used to produce our products have increased substantially. For example, using the BLS Index as an indicator the price of stainless steel has increased 27.7% over the last MOU. (See charts below) Most of our stainless parts are imported from China. Since stainless steel is so prevalent in the system it will obviously impact costs. See the breakdown below:

Material Cost Adder		2021	316SS	316 SS Index	316 SS Index	Percent	
		USD Price	Adjustment	August 2021	August 2021	Increase	Increase Amt
Lamp racks (qty. 325)	29% of Material Cost is 316SS	\$ 2,180,990	\$ 632,487	97.7	124.8	27.7%	\$ 175,439
Level Control Weir (qty. 5)	100% of Material Cost is 316SS	\$ 85,483	\$ 85,483	97.7	124.8	27.7%	\$ 23,711
Stilling Plates (qty. 10)	100% of Material Cost is 316SS	\$ 54,250	\$ 54,250	97.7	124.8	27.7%	\$ 15,048
IBA (qty. 25)	100% of Material Cost is 316SS	\$ 253,580	\$ 253,580	97.7	124.8	27.7%	\$ 70,338
IBA Bank Guides (qty. 100)	100% of Material Cost is 316SS	\$ 15,341	\$ 15,341	97.7	124.8	27.7%	\$ 4,255
							\$ 288,791.28

Three: Labor increases due to design changes. Based on design changes, there is an increase of \$39,300. This amount will be invoiced against the existing Professional Services Agreement for design support services and is not part of the MOU price increase.

The previous 2020 MOU procurement price of \$5,634,700 will be increased by \$288,791.28 for a new Final Price of \$5,923,491.28. If steel prices are reduced at the time of procurement by the City's contractor, the Final Price will be reduced accordingly.

Please review the attachments and do not hesitate to contact me if you have any questions.

Best Regards,

Kris E. Sticinski

Kris Sticinski

Americas Sales Director – Disinfection & Filtration plus Electrochlorination



De Nora UV Technologies, LLC

Attachment: Cost breakdown

cc Doug Wing, Carollo Engineers

Attachment

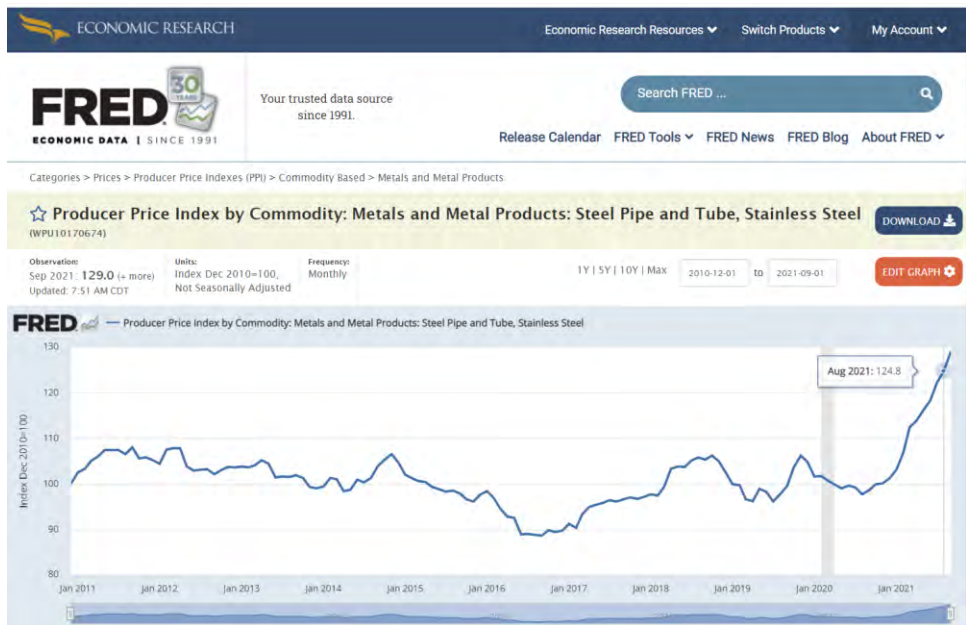
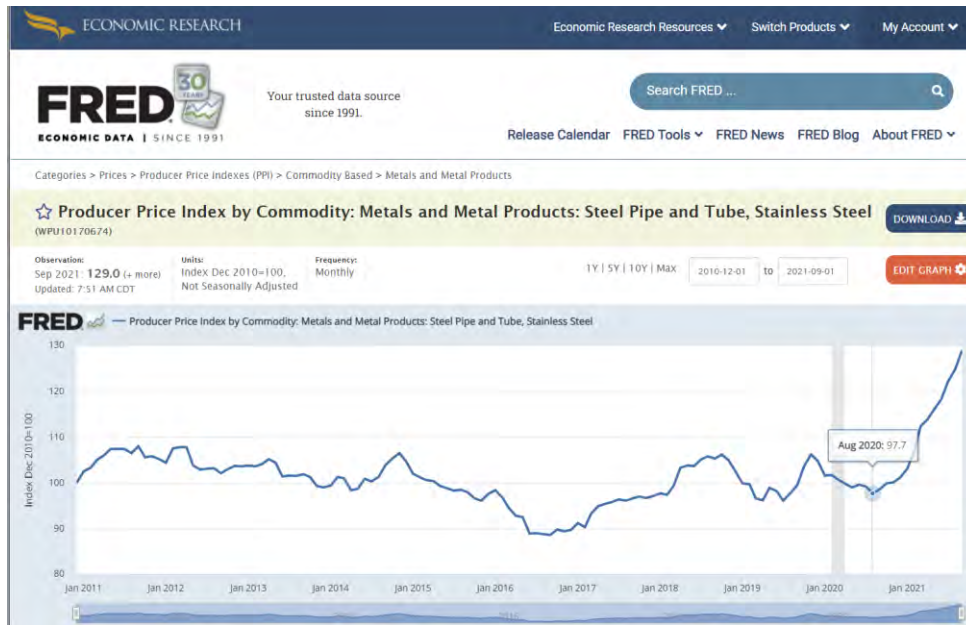

Price of steel continues to soar

Hot-Rolled Coil Steel Futures Continuous Contract

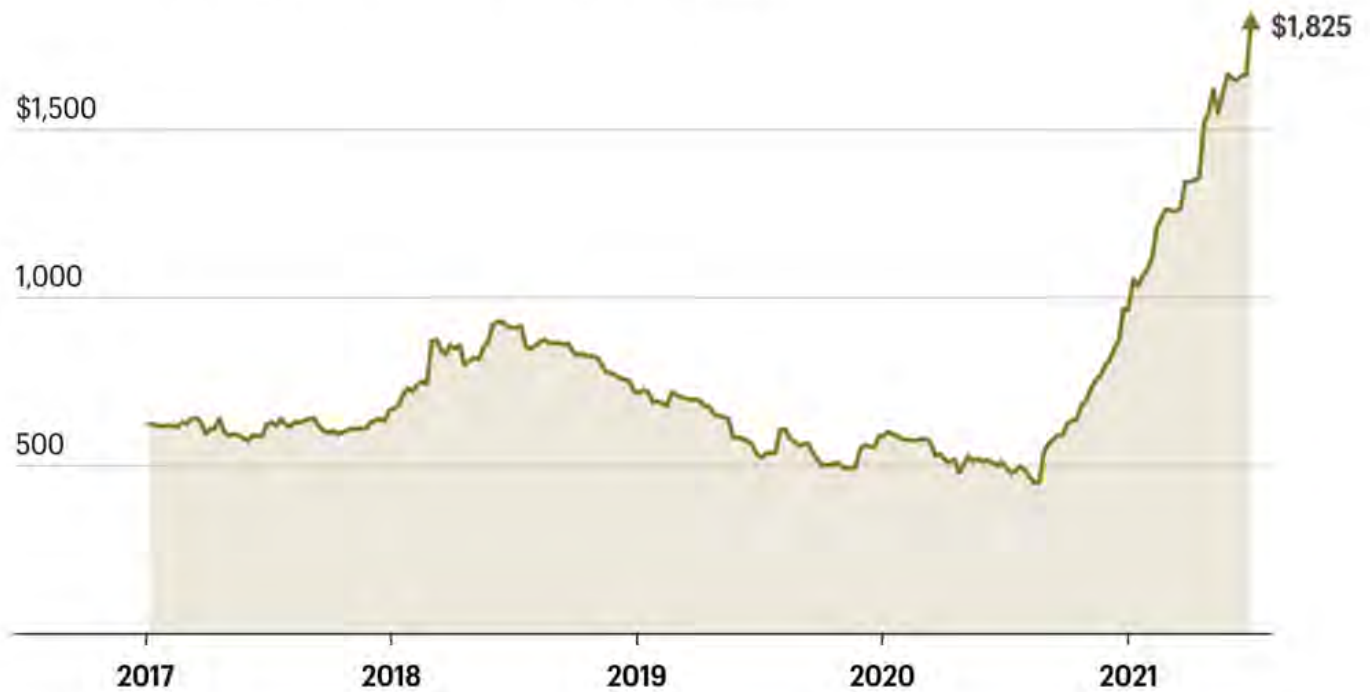

CHART: LANCE LAMBERT • SOURCE: MARKETWATCH

FORTUNE



EXHIBIT D

CERTIFICATE OF LIABILITY INSURANCE

DATE(MM/DD/YYYY)
01/05/2021

THIS CERTIFICATE IS ISSUED AS A MATTER OF INFORMATION ONLY AND CONFERS NO RIGHTS UPON THE CERTIFICATE HOLDER. THIS CERTIFICATE DOES NOT AFFIRMATIVELY OR NEGATIVELY AMEND, EXTEND OR ALTER THE COVERAGE AFFORDED BY THE POLICIES BELOW. THIS CERTIFICATE OF INSURANCE DOES NOT CONSTITUTE A CONTRACT BETWEEN THE ISSUING INSURER(S), AUTHORIZED REPRESENTATIVE OR PRODUCER, AND THE CERTIFICATE HOLDER.

IMPORTANT: If the certificate holder is an ADDITIONAL INSURED, the policy(ies) must have ADDITIONAL INSURED provisions or be endorsed. If SUBROGATION IS WAIVED, subject to the terms and conditions of the policy, certain policies may require an endorsement. A statement on this certificate does not confer rights to the certificate holder in lieu of such endorsement(s).

PRODUCER Aon Risk Services Northeast, Inc. Cleveland OH Office 950 Main Avenue Suite 1600 Cleveland OH 44113 USA	CONTACT NAME: PHONE (A/C. No. Ext): (866) 283-7122 FAX (A/C. No.): (800) 363-0105		
	E-MAIL ADDRESS:		
INSURED De Nora Water Technologies, LLC 7590 Discovery Lane Concord OH 44077 USA	INSURER(S) AFFORDING COVERAGE		NAIC #
	INSURER A: Lexington Insurance Company		19437
	INSURER B: Travelers Property Cas Co of America		25674
	INSURER C: Travelers Casualty Co of CT		36170
	INSURER D: AIG Specialty Insurance Company		26883
	INSURER E:		
INSURER F:			

Holder Identifier :

COVERAGES **CERTIFICATE NUMBER:** 570085655052 **REVISION NUMBER:**

THIS IS TO CERTIFY THAT THE POLICIES OF INSURANCE LISTED BELOW HAVE BEEN ISSUED TO THE INSURED NAMED ABOVE FOR THE POLICY PERIOD INDICATED. NOTWITHSTANDING ANY REQUIREMENT, TERM OR CONDITION OF ANY CONTRACT OR OTHER DOCUMENT WITH RESPECT TO WHICH THIS CERTIFICATE MAY BE ISSUED OR MAY PERTAIN, THE INSURANCE AFFORDED BY THE POLICIES DESCRIBED HEREIN IS SUBJECT TO ALL THE TERMS, EXCLUSIONS AND CONDITIONS OF SUCH POLICIES. LIMITS SHOWN MAY HAVE BEEN REDUCED BY PAID CLAIMS. **Limits shown are as requested**

INSR LTR	TYPE OF INSURANCE	ADDL INSD	SUBR WVD	POLICY NUMBER	POLICY EFF (MM/DD/YYYY)	POLICY EXP (MM/DD/YYYY)	LIMITS	
D	<input checked="" type="checkbox"/> COMMERCIAL GENERAL LIABILITY <input type="checkbox"/> CLAIMS-MADE <input checked="" type="checkbox"/> OCCUR GEN'L AGGREGATE LIMIT APPLIES PER: <input checked="" type="checkbox"/> POLICY <input type="checkbox"/> PRO-JECT <input type="checkbox"/> LOC OTHER:			EG5404900	12/31/2020	12/31/2021	EACH OCCURRENCE	\$1,000,000
							DAMAGE TO RENTED PREMISES (Ea occurrence)	\$300,000
							MED EXP (Any one person)	\$25,000
							PERSONAL & ADV INJURY	\$1,000,000
							GENERAL AGGREGATE	\$2,000,000
							PRODUCTS - COMP/OP AGG	\$2,000,000
							Pollution Liability Coverage	\$1,000,000
B	AUTOMOBILE LIABILITY <input checked="" type="checkbox"/> ANY AUTO <input type="checkbox"/> OWNED AUTOS ONLY <input type="checkbox"/> HIRED AUTOS ONLY <input checked="" type="checkbox"/> Comp/Coll \$1,000 <input type="checkbox"/> SCHEDULED AUTOS <input type="checkbox"/> NON-OWNED AUTOS ONLY			810-9M169639-20-14-G	12/31/2020	12/31/2021	COMBINED SINGLE LIMIT (Ea accident)	\$1,000,000
							BODILY INJURY (Per person)	
							BODILY INJURY (Per accident)	
							PROPERTY DAMAGE (Per accident)	
D	<input type="checkbox"/> UMBRELLA LIAB <input checked="" type="checkbox"/> OCCUR <input checked="" type="checkbox"/> EXCESS LIAB <input type="checkbox"/> CLAIMS-MADE <input type="checkbox"/> DED <input type="checkbox"/> RETENTION			EGU5405666	12/31/2020	12/31/2021	EACH OCCURRENCE	\$4,000,000
							AGGREGATE	\$4,000,000
C	WORKERS COMPENSATION AND EMPLOYERS' LIABILITY ANY PROPRIETOR / PARTNER / EXECUTIVE OFFICER/MEMBER EXCLUDED? (Mandatory in NH) If yes, describe under DESCRIPTION OF OPERATIONS below		Y/N N	UB2P4086622014G	12/31/2020	12/31/2021	<input checked="" type="checkbox"/> PER STATUTE <input type="checkbox"/> OTHER	
			N/A				E.L. EACH ACCIDENT	\$1,000,000
							E.L. DISEASE-EA EMPLOYEE	\$1,000,000
							E.L. DISEASE-POLICY LIMIT	\$1,000,000
A	E&O-PL-Primary			015819767 SIR applies per policy terms & conditions	06/30/2020	06/30/2021	Aggregate Per Claim	\$2,000,000 \$2,000,000

Certificate No : 570085655052

DESCRIPTION OF OPERATIONS / LOCATIONS / VEHICLES (ACORD 101, Additional Remarks Schedule, may be attached if more space is required)
 Evidence of Coverage.

CERTIFICATE HOLDER**CANCELLATION**

De Nora Water Technologies, LLC 7590 Discovery Lane Concord OH 44077 USA	SHOULD ANY OF THE ABOVE DESCRIBED POLICIES BE CANCELLED BEFORE THE EXPIRATION DATE THEREOF, NOTICE WILL BE DELIVERED IN ACCORDANCE WITH THE POLICY PROVISIONS.
	AUTHORIZED REPRESENTATIVE <i>Aon Risk Services Northeast, Inc.</i>

