

GENERAL NOTES

- ALL WORK SHALL COMPLY WITH THE CALIFORNIA RESIDENTIAL CODE (CRC), THE 2019 CALIFORNIA BUILDING CODE (CBC), THE 2019 CALIFORNIA ELECTRICAL CODE (CEC), 2019 CALIFORNIA MECHANICAL CODE (CMC), 2019 CALIFORNIA PLUMBING CODE (CPC), 2019 CALIFORNIA ENERGY EFFICIENCY STANDARDS CODE (CEES), 2019 CALIFORNIA FIRE CODE (CFC), 2019 CALIFORNIA GREEN BUILDING STANDARDS CODE (CGBS OR CALGREEN) AND ALL OTHER APPLICABLE CALIFORNIA CODES AND ALL REGULATIONS SET FORTH BY THE CITY OF SANTA ROSA.
- THE GENERAL CONTRACTOR AND SUB CONTRACTOR SHALL TAKE ALL NECESSARY PRECAUTIONS TO PROTECT THE FOLLOWING ITEMS DURING CONSTRUCTION: EXISTING LANDSCAPING, TREES AND PLANT MATERIAL, ADJACENT FENCING, ADJACENT PROPERTIES, EXISTING STRUCTURES, UTILITIES AND OTHER IMPROVEMENTS INTENDED TO REMAIN.
- PRIOR TO COMMENCING WORK, THE CONTRACTOR AND APPROPRIATE SUBCONTRACTORS SHALL PERFORM A THOROUGH INSPECTION OF THE SITE AND EXISTING BUILDINGS TO VERIFY ALL EXISTING CONDITIONS AND SHALL NOTIFY THE ARCHITECT OF ANY DISCREPANCIES IN THE DRAWINGS. CONTRACTOR SHALL VERIFY LOCATIONS OF ALL UTILITIES TO BE CAPPED, REMOVED, OR RELOCATED INCLUDING: WATER, SEWER, GAS, ELECTRICAL, SUBSURFACE DRAINAGE, TELEPHONE AND CABLE. COORDINATE ANY UTILITY SHUT OFF WITH THE ARCHITECT AND OWNER 48 HOURS PRIOR TO SHUTDOWN.
- THE DESIGN, LAYOUT AND INSTALLATION OF BRACING SHORING, AND ALL TEMPORARY SUPPORTS IS THE SOLE RESPONSIBILITY OF THE CONTRACTOR AND HAS NOT BEEN PROVIDED BY THE ARCHITECT OR THE STRUCTURAL ENGINEER. THE CONTRACTOR IS RESPONSIBLE FOR THE SAFE AND PROFESSIONAL INSTALLATION OF AFOREMENTIONED SUPPORT SYSTEMS AND FOR THE STABILITY OF THE EXISTING STRUCTURE AT ALL TIMES DURING THE COURSE OF THE WORK.
- STRUCTURAL OBSERVATION SHALL BE REQUIRED BY THE ENGINEER FOR CONFORMANCE WITH THE APPROVED STRUCTURAL PLANS. THE OWNER SHALL EMPLOY A REGISTERED DESIGN PROFESSIONAL TO PERFORM STRUCTURAL OBSERVATION AS DEFINED IN SECTION 1710 OF THE 2013 CBC. STRUCTURAL OBSERVATION AND / OR SPECIAL INSPECTIONS ARE NOT A SUBSTITUTE FOR INSPECTION BY THE BUILDING OFFICIAL OR BUILDING INSPECTOR. ANY WORK REQUIRING SPECIAL INSPECTION THAT IS INSTALLED OR COVERED WITHOUT APPROVAL OF THE BUILDING OFFICIAL, THE SPECIAL INSPECTOR, AND THE DESIGN ENGINEER IS SUBJECT TO REMOVAL. A LETTER, WET STAMPED AND SIGNED, MUST BE SUBMITTED TO THE BUILDING OFFICIAL DESCRIBING THE SPECIFIC OBSERVATIONS THAT WERE MADE AND THE SPECIFIC STRUCTURAL WORK APPROVED AND THAT THE CONSTRUCTION CONFORMS TO THE DESIGN. THIS IS IN ADDITION TO ALL MUNICIPAL REQUIRED INSPECTIONS.
- DRAWINGS SHALL NOT BE SCALED. WRITTEN DIMENSIONS SHALL GOVERN. ALL DIMENSIONS ARE TO FACE OF STUD UNLESS OTHERWISE NOTED. REPORT ANY DISCREPANCIES FOUND BETWEEN THE DRAWINGS AND THE FIELD CONDITIONS TO THE ARCHITECT PRIOR TO PROCEEDING WITH WORK.
- DETAILS NOT FULLY SHOWN SHALL BE OF SAME NATURE AS OTHER SIMILAR CONDITIONS.

PROJECT STATISTICS

A. P. #:	180-750-048
ZONING:	CG-H
OCCUPANCY GROUPS:	M
CONSTRUCTION TYPE:	VB
LOT AREA:	7,884 SQ. FT.
EXISTING AREA:	
FIRST FLOOR:	975 SQ. FT.
SECOND FLOOR:	530 SQ. FT.
TOTAL:	1,505 SQ. FT.
AREA TO BE REMOVED:	
FIRST FLOOR:	0 SQ. FT.
SECOND FLOOR:	75 SQ. FT.
PROPOSED NEW AREA:	
FIRST FLOOR:	975 SQ. FT.
SECOND FLOOR:	455 SQ. FT.
TOTAL:	1,430 SQ. FT.

PROJECT DESCRIPTION

- THE PROJECT IS TO REPAIR THE EXISTING BUILDING AT 349 COLLEGE AVENUE FOR USE AS OFFICE SPACE FOR THE ADJACENT CANNABIS DISPENSARY AT 353 COLLEGE AVENUE. THE WORK WILL INCLUDE:
- THE REMOVAL OF THE SECOND FLOOR HALLWAY THAT WAS A LATER ADDITION TO THE BUILDING.
 - REPAIRS TO FIRE AND WATER DAMAGE TO THE INTERIOR AND EXTERIOR OF THE BUILDING.
 - REFURBISH INTERIOR AND EXTERIOR FINISHES AND COMPLETE DEFERRED MAINTENANCE.
 - REMOVAL OF THE CONCRETE WALL COVERING AT THE PORCH.
 - REPLACE DAMAGED WINDOWS AND EXTERIOR DOORS.
 - REPLACE ASPHALT SHINGLE ROOF.
 - REPAIR AND REPLACE ELECTRICAL, MECHANICAL AND PLUMBING.
 - CONVERT EXISTING SECOND FLOOR SPACE TO ATTIC SPACE WITH AN INTERNAL ATTIC ACCESS.

DRAWING INDEX

A0.0	PROJECT STATISTICS / PROJECT DESCRIPTION / DRAWING INDEX
A0.1	SITE PLAN
A1.0	PROPOSED FIRST FLOOR PLAN / SECOND FLOOR DEMOLITION PLAN / PROPOSED SECOND FLOOR PLAN
A2.0	EXISTING ELEVATIONS
A2.1	PROPOSED ELEVATIONS
A3.0	SITE PHOTOS / MATERIALS AND COLORS
A4.0	BUILDING LIGHTING CUT SHEETS

LOCATION MAP

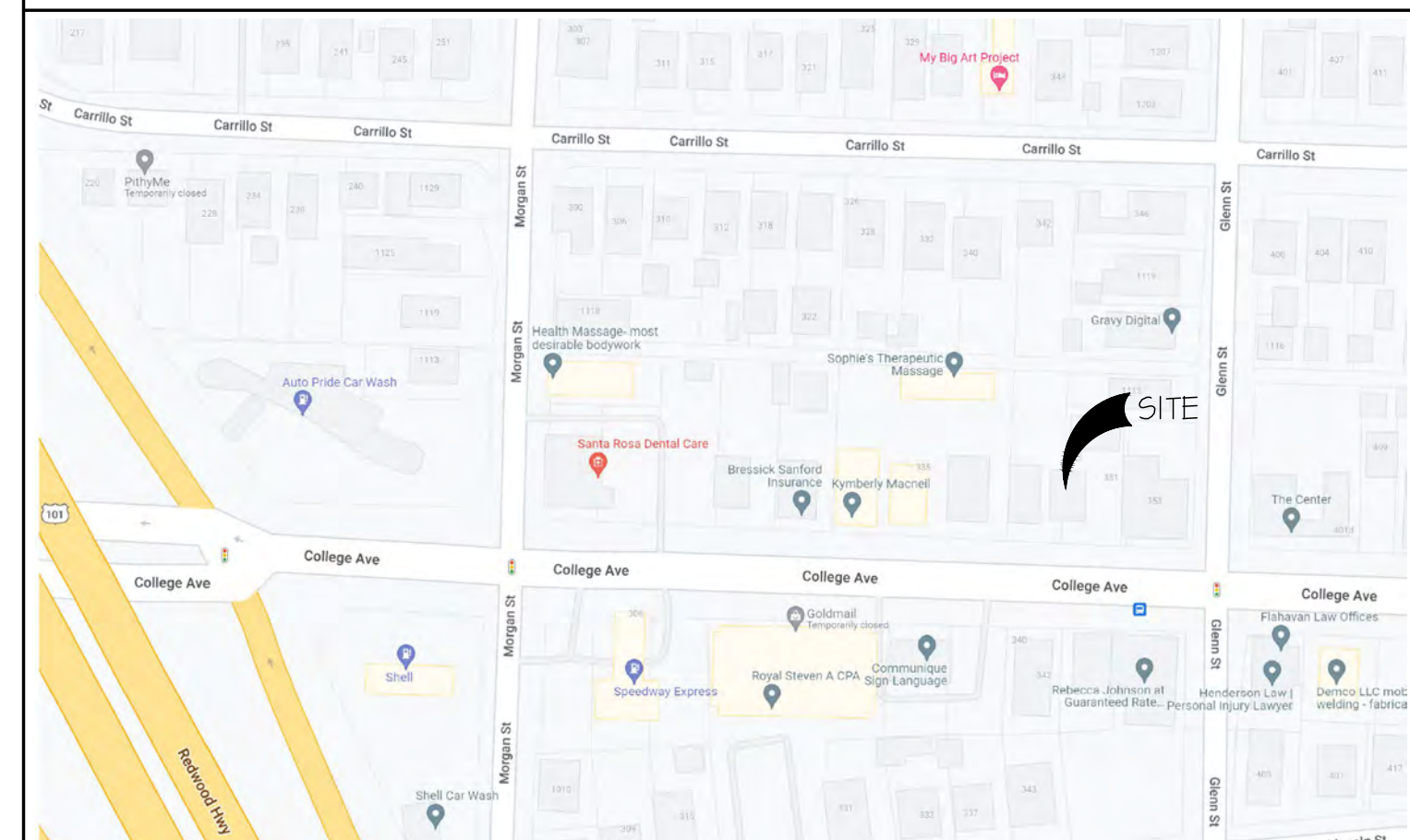

Revisions	By

File

RPS DESIGN HEREBY RESERVES ITS COMMON LAW COPYRIGHTS IN THESE PLANS. THESE PLANS SHALL BE RETURNED UPON REQUEST. DESIGN, THESE PLANS, DESIGNS AND PLANS ARE NOT TO BE REPRODUCED, COPIED, EITHER WHOLLY OR IN PART, OR TRANSMITTED IN ANY FORM OR BY ANY MEANS, ELECTRONIC OR MECHANICAL, INCLUDING PHOTOCOPYING, RECORDING, OR BY ANY INFORMATION STORAGE AND RETRIEVAL SYSTEM, WITHOUT THE EXPRESS WRITTEN PERMISSION OF RPS DESIGN. RPS DESIGN SHALL HAVE PRECEDENCE OVER ANY OTHER PROFESSIONAL OR CONSULTANT'S WORK. RPS DESIGN SHALL BE RESPONSIBLE FOR THE ACCURACY OF THE DIMENSIONS AND CONDITIONS OF THE JOB AND THE DIMENSIONS AND CONDITIONS APPEARING ON THESE PLANS. THESE PLANS SHALL BE RETURNED UPON REQUEST.

REMODEL TO
349 COLLEGE AVE
 SANTA ROSA, CA
 APN: 180-750-048

PO BOX 111
 LAGUNITAS, CALIFORNIA 94938
 (415) 314-0525
 rpsuttman@rpsdesign.net

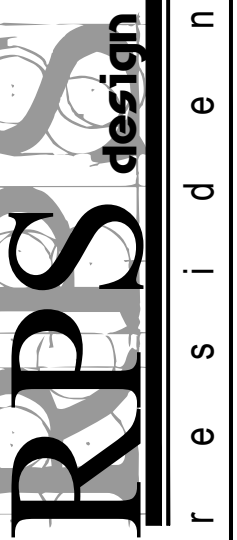

PROJECT STATISTICS / PROJECT DESCRIPTION / DRAWING INDEX

Job No:
 Drawn:
 Date: 7-20-22

Sheet
A0.0

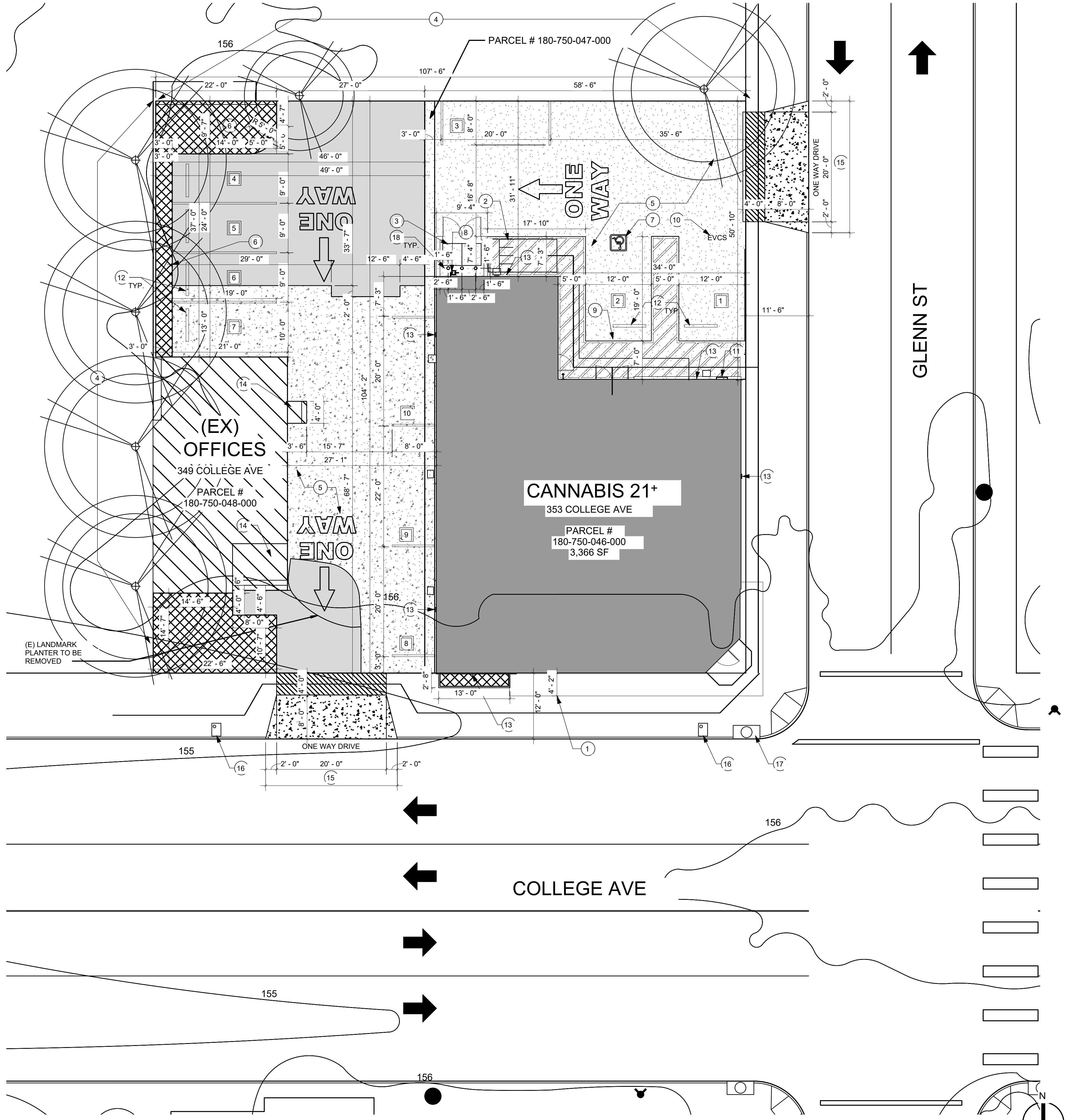

1 PROPOSED SITE PLAN - ENLARGED
1" = 10'-0"

SITE PLAN LEGEND

(E) = EXISTING (N) = NEW	
	(E) ADJACENT BUILDING & ACCESS STAIRS TO REMAIN (NOT IN SCOPE)
	(E) ASPHALT AREA PARKING
	(N) ASPHALT AREA PARKING APPROX. 1,719 SF.
	(E) CONCRETE PARKING
	(N) CONCRETE / DRIVE PER STANDARD 250A
	(E) SIDEWALK TO REMAIN
	(N) LANDSCAPING SEE LANDSCAPE SHEET FOR SF.
	(E) ELECTRICAL POLE AND STREET LIGHT
	(N) BUILDING SECURITY LIGHTS
	NOTE: SEE REFLECTED CEILING PLAN FOR ADDITIONAL EXTERIOR LIGHTING NOT SHOWN HERE
	(E) FIRE HYDRANT
	(N) PARKING STALL STRIPING LAYOUT
	PROPERTY LINE
	PATH OF TRAVEL
	EXISTING TREES TO REMAIN - ALL ON ADJACENT PROPERTIES SEE LANDSCAPE SHEET

City of Santa Rosa
Planning & Economic
Development Department
Jul 27, 2022
RECEIVED

PARKING COUNT

COMMERCIAL CANNABIS FACILITY PARKING REQUIREMENTS:

RETAIL SALES & DISTRIBUTION	10 SPACES REQUIRED
1 SPACES FOR 250 SF - 3,300SF	PER CUP RESOLUTION NO. 12065 A PARKING REDUCTION OF (3) SPACES SHALL BE ALLOWED
TOTAL PARKING REQUIRED	10 SPACES REQUIRED AND PROVIDED
NON-ADA SPACES PROVIDED	8 PARKING SPACES PROVIDED
REQUIRED ADA PARKING	1 VAN ACCESSIBLE PARKING SPACE PROVIDED
REQUIRED ELECTRICAL VEHICLE SPACE	1 SPACE REQUIRED (SEE BELOW)
TOTAL PARKING	10 PARKING SPACES REQUIRED & PROVIDED
REQUIRED ELECTRIC VEHICLE SPACES	1 SPACE REQUIRED
(1) VAN	
REQUIRED LOADING SPACES	NO LOADING SPACE REQUIRED (PER SECTION 20-36.100 TABLE 3-8)
GROSS FLOOR AREA 3,350 SF	
REQUIRED BICYCLE PARKING FOR SITE	1 SPACE IS REQUIRED PER RESOLUTION NO. 12065 AND 4 SPACES HAS BEEN PROVIDED
MINIMUM (1) SPACE PER 5,000 SF- CLASS TWO	

- ### PLANNING DIVISION - GENERAL NOTES
- COMPLIANCE WITH ALL APPLICABLE OPERATIONAL PROVISIONS OF ZONING CODE CHAPTER 20-46 IS REQUIRED.
 - COMPLIANCE WITH CITY GRAFFITI ABATEMENT PROGRAM STANDARDS FOR GRAFFITI REMOVAL (CITY CODE 10-17.080.)
 - THE BUILDING MATERIALS, ELEVATIONS, AND APPEARANCE OF THIS PROJECT, AS PRESENTED FOR ISSUANCE OF A BUILDING PERMIT, SHALL BE THE SAME AS THAT APPROVED BY THE PLANNING COMMISSION. ANY FUTURE ADDITIONS, EXPANSIONS, REMODELING, ETC., WILL BE SUBJECT TO REVIEW AND APPROVAL OF THE PLANNING DIVISION.
 - NO SIGNS ARE APPROVED AS PART OF THIS CONDITIONAL USE PERMIT. ALL SIGNS REQUIRE A SEPARATE REVIEW PROCESS AND BOTH PLANNING AND BUILDING PERMITS.
 - EXTERIOR LIGHTING SHALL BE IN COMPLIANCE WITH ZONING CODE SECTION 20-30.080.
 - ALL ROOF APPURTENANCES, ACCESSORY EQUIPMENT, AND METERS SHALL BE TOTALLY SCREENED FROM PUBLIC VIEW BY AN ARCHITECTURAL DESIGN ELEMENT APPROVED BY THE DESIGN REVIEW BOARD OR PLANNING DIVISION.
 - A RESERVATION OF ACCESS EASEMENT FOR THE PROPOSED CIRCULATION SHALL BE RECORDED PRIOR TO ISSUANCE OF BUILDING PERMITS.
 - A RESERVATION COVENANT FOR OFF-SITE PARKING SHALL BE RECORDED PRIOR TO ISSUANCE OF BUILDING PERMITS.
 - AS IDENTIFIED IN THE W-TRANS FOCUSED TRAFFIC STUDY, DATED JULY 21, 2021, THAT 50% OR FIVE (5) PARKING SPACES SHALL INCLUDE SIGNING ON SITE INDICATING 30-MINUTE PARKING LIMITS FOR CUSTOMERS AND ENFORCED BY THE CANNABIS RETAIL OPERATOR.
 - THE PROJECT SHALL PROVIDE 12 COVERED BICYCLE PARKING SPACES AS PROPOSED IN THE PROJECT DESCRIPTION.
 - TWO (2) PARKING SPACES ON THE PARCEL AT 349 COLLEGE AVE. SHALL BE DESIGNATED AND SIGNED AS RESERVED FOR THE EXISTING OFFICE USE. THESE RESERVATIONS OF PARKING SPACES MAY SPECIFY A TIMEFRAME FOR WHICH PARKING IS RESERVED SO THAT THE SPACES CAN BE USED BY CUSTOMERS VISITING 353 COLLEGE AVE. OUTSIDE OF RESERVED HOURS.
 - OBTAIN A MINOR LANDMARK ALTERATION PERMIT FOR REMOVAL OF THE PLANTER STRIP AND NEW PARKING AREA ON THE PROPERTY LOCATED AT 349 COLLEGE AVENUE, TO ACCOMMODATE THE PROPOSED ONSITE CIRCULATION.
 - AS REQUESTED BY THE RIDGWAY HISTORIC PRESERVATION DISTRICT NEIGHBORHOOD ASSOCIATION, THE PROJECT SHALL REPAINT THE BUILDING LOCATED AT 353 COLLEGE AVENUE A NEUTRAL COLOR.
 - EMPLOYEE PARKING SHALL BE ENCOURAGED AT OFFSITE LOCATIONS THAT ARE NOT ON PUBLIC STREETS ADJACENT TO THE PROJECT SITE.
 - ALL CANNABIS PRODUCT DELIVERIES TO THE DISPENSARY SHALL BE LIMITED TO THE HOURS OF 6 A.M. TO 10 P.M. DAILY.

SITE PLAN KEYNOTES

(#)	(EX) = EXISTING (N) = NEW
1	(EX) EXISTING 4'-2" OVERHEAD SIGNAGE CANOPY
2	(4) BICYCLE PARKING SPACES - COVERED BY A 4'-2" EXISTING OVERHEAD CANOPY.
3	TRASH BINS - OWNER TO SUPPLY REGULAR AND RECYCLE TRASH BINS WITH BUILT IN LIDS. COORDINATE BIN SIZE AND LOCATION WITH GENERAL CONTRACTOR TO ENSURE PROPER CURB SITE CONFIGURATIONS FOR BINS.
4	DEMO EXISTING FENCING AND ALL ASSOCIATED COMPONENTS AND PROVIDE NEW 6 FOOT TALL x 8 FOOT LONG CEDAR LATTICE TOP PRIVACY SPACED PICKET FENCING BY LOWES OR EQUAL. PROVIDE 4x4 PRESSURE TREATED WOOD POSTS AT PANEL EDGES SEE DETAILS. PROVIDE 4x4 PRESURE TREATED WOOD POST @ 4'-0" MAX. ENTIRE LENGTH OF FENCING
5	(EX) PAVING TO REMAIN. PATCH / REPAIR AS NEEDED AND PROVIDE NEW SLURRY SEAL COATING. RESTRIPE ENTIRE PAVING AREA AS INDICATED.
6	(N) PLANTER AREA - SEE SITE DETAIL SHEET FOR TYPICAL CONCRETE CURB DETAIL
7	(N) HANDICAP PARKING STALL. SEE DETAIL 3 / A0.3B
8	(EX) GAS METER
9	(N) ADA SIGNAGE AT PARKING STALL PER DETAIL 2 / A0.3B
10	(N) VAN ACCESSIBLE ELECTRIC VEHICLE FUTURE CHARGING STATION - PROVIDE 1" CONDUIT & PULLSTRING FOR FUTURE EVCS STATIONS. SEE ELECTRICAL SITE PLAN GENERAL CONTRACTOR TO PROVIDE UNDERGROUND CONDUIT & PULL STRING FOR INSTALLATION. OPERABLE PARTS AND POINT-OF-SALE DEVICES SHALL BE COMPLIANT WITH ACCESSIBLE FRONT / SIDE APPROACH REQUIREMENTS AS PER CBC 11B-309, FIGURES 11B-308.2.1 AND 11B-308.3.1. ALL REQUIRED PAINTING AND SIGNAGE SHALL BE PER CITY OF SANTA ROSA STANDARDS, REFER TO DETAIL 5 / A0.3B
11	(EX) BUILDING ELECTRICAL EQUIPMENT. SEE ELECTRICAL DRAWINGS
12	(N) CONCRETE WHEEL STOPS PER DETAIL 10 / A0.3B
13	(N) NO LINGERING/LOITERING SIGNAGE - OBTAIN SIGNAGE FROM THE SHERIFF'S DEPARTMENT
14	(EX) STAIRS TO REMAIN NOT IN SCOPE
15	(N) DRIVE SHALL BE MODIFIED AS REQUIRED TO COMPLY WITH CITY OF SANTA ROSA STANDARD DRAWING 250A
16	(EX) WATER METER
17	(EX) STROM DRAIN
18	(N) BOLLARDS, SEE DETAIL 9 / A6.2

Revisions	By
File	
REMODEL TO	APN: 180-750-048
349 COLLEGE AVE	SANTA ROSA, CA
LAGUNITAS, CALIFORNIA 94938	PO BOX 111
(415) 314-0525	rsuttman@rpsdesign.net
rpsdesign	
SITE PLAN	
Job No:	
Drawn:	
Date: 7-20-22	
Sheet	
A0.1	

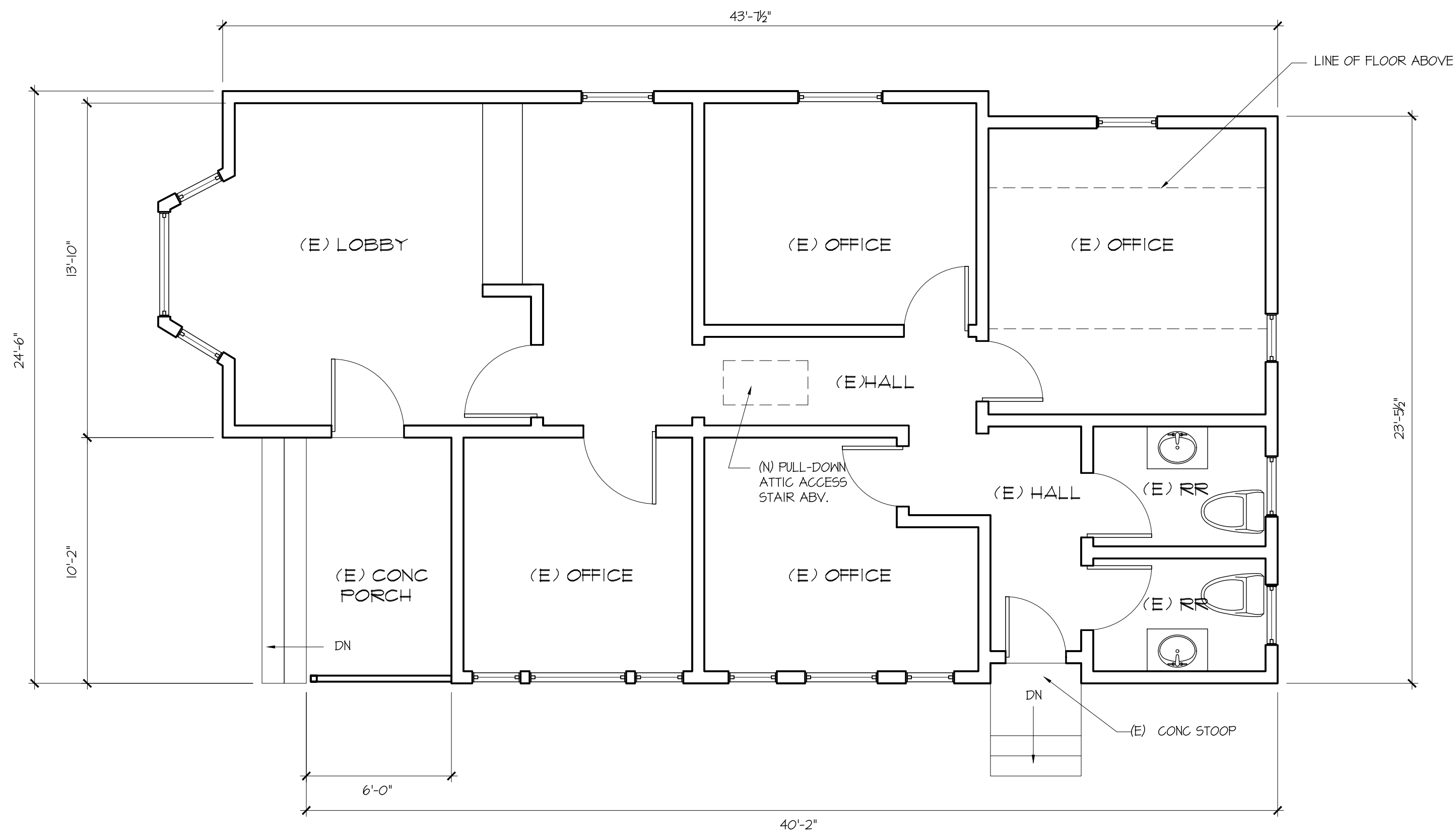

1
-
1/4"=1'-0"
PROPOSED FIRST FLOOR PLAN

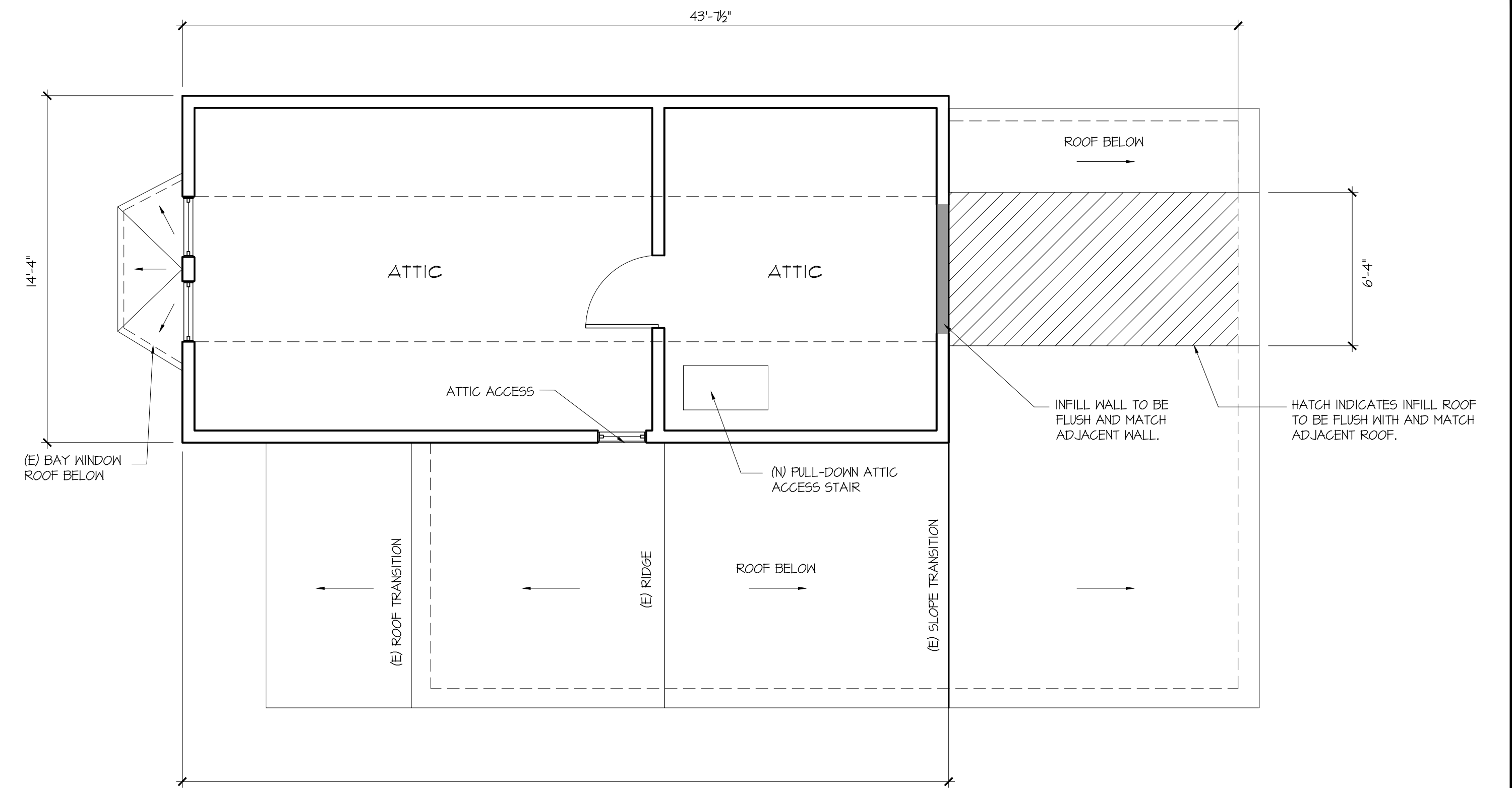

2
-
1/4"=1'-0"
PROPOSED SECOND FLOOR PLAN

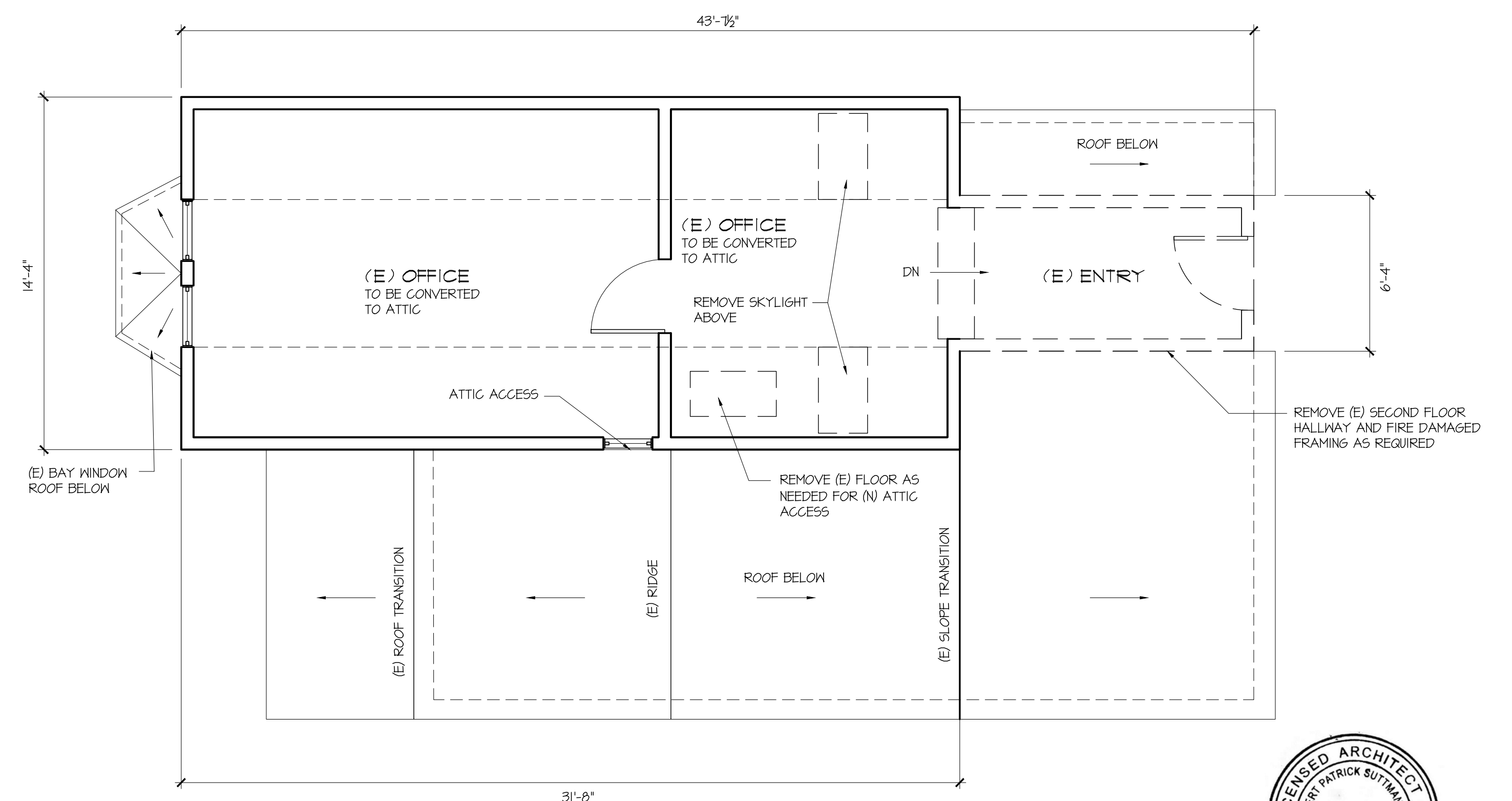

3
-
1/4"=1'-0"
SECOND FLOOR DEMOLITION PLAN



Revisions	By

File

RPS DESIGN HEREBY REPRESENTS COMMON LAW COPYRIGHTS IN THESE ARCHITECTURAL AND ENGINEERING DRAWINGS. THESE DESIGN AND PLANS ARE NOT TO BE REPRODUCED, COPIED, REPRODUCED, OR TRANSMITTED IN ANY FORM OR BY ANY MEANS, WITHOUT THE WRITTEN PERMISSION OF RPS DESIGN. RPS DESIGN SHALL BE RESPONSIBLE FOR THE ACCURACY AND COMPLETENESS OF THE INFORMATION, DATA, CONDITIONS AND SPECIFICATIONS APPEARING ON THESE PLANS. THESE PLANS SHALL BE RETURNED UPON REQUEST.

REMODEL TO
349 COLLEGE AVE
SANTA ROSA, CA
APN: 180-750-048

PO BOX 111
LAGUNITAS, CALIFORNIA 94938
(415) 314-0525
rpsuttman@rpsdesign.net

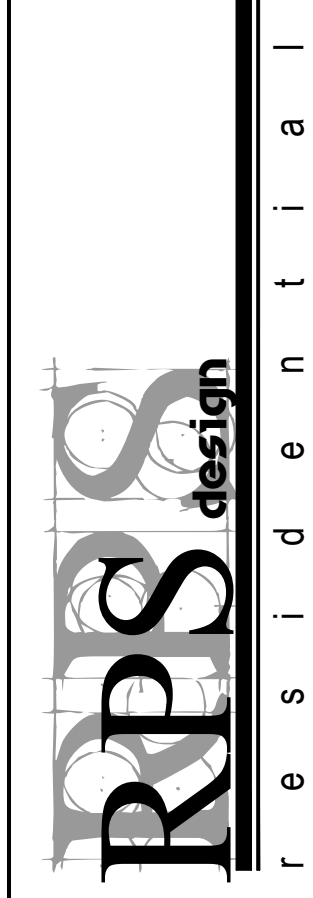

FIRST FLOOR PLAN

Job No:
Drawn:
Date: 7-20-22

Sheet
A1.0

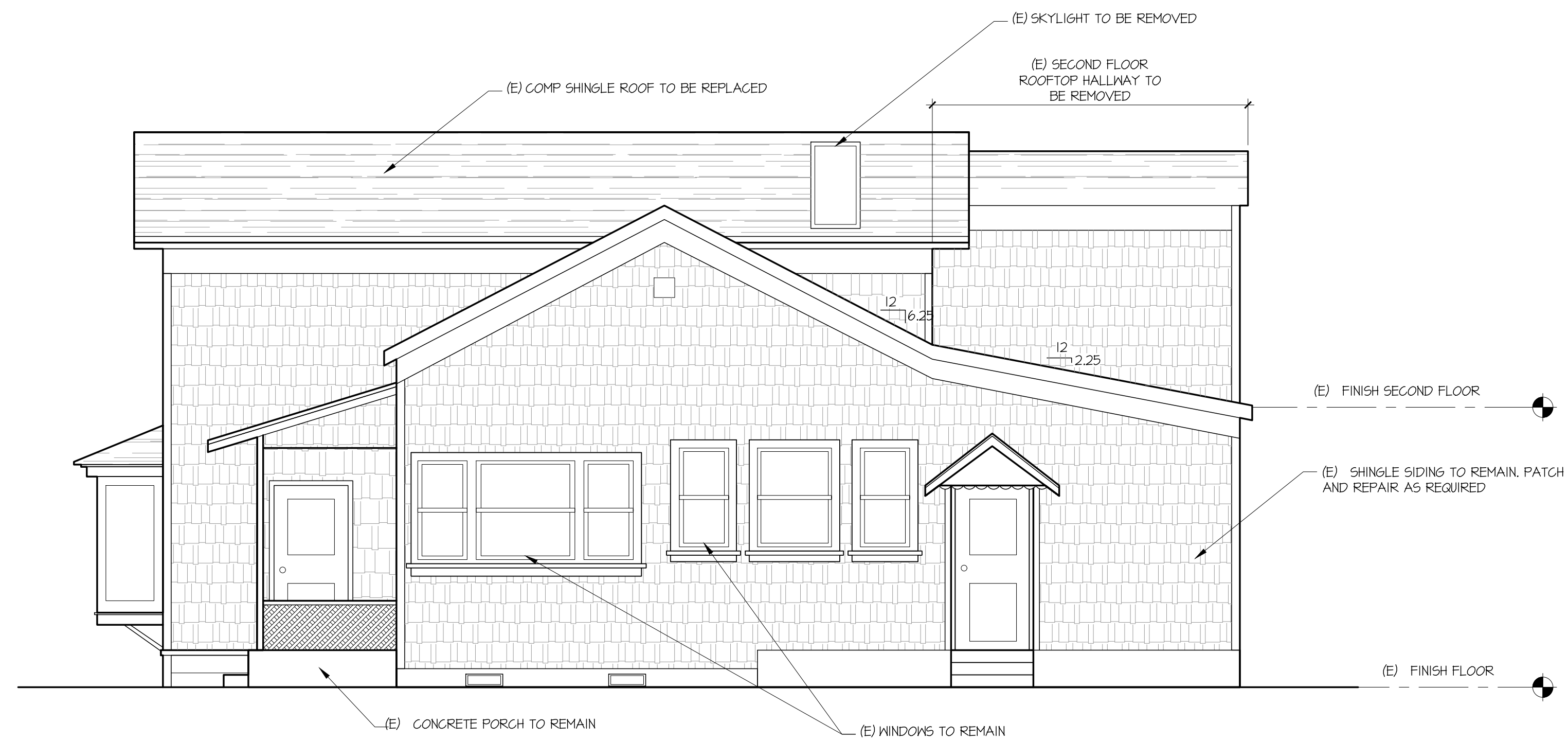

1 EXISTING EAST ELEVATION
1/4"=1'-0"

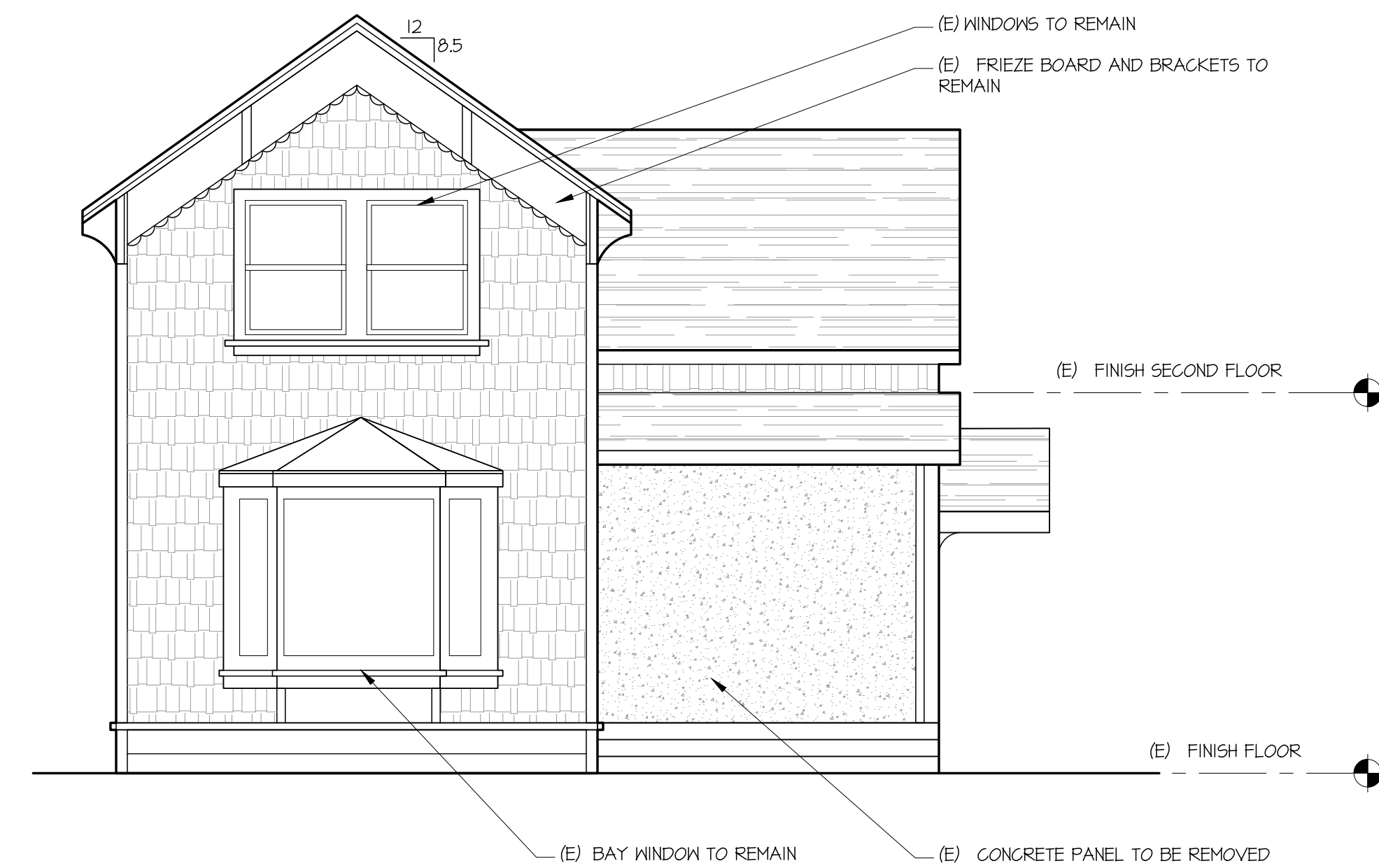

2 EXISTING SOUTH ELEVATION
1/4"=1'-0"

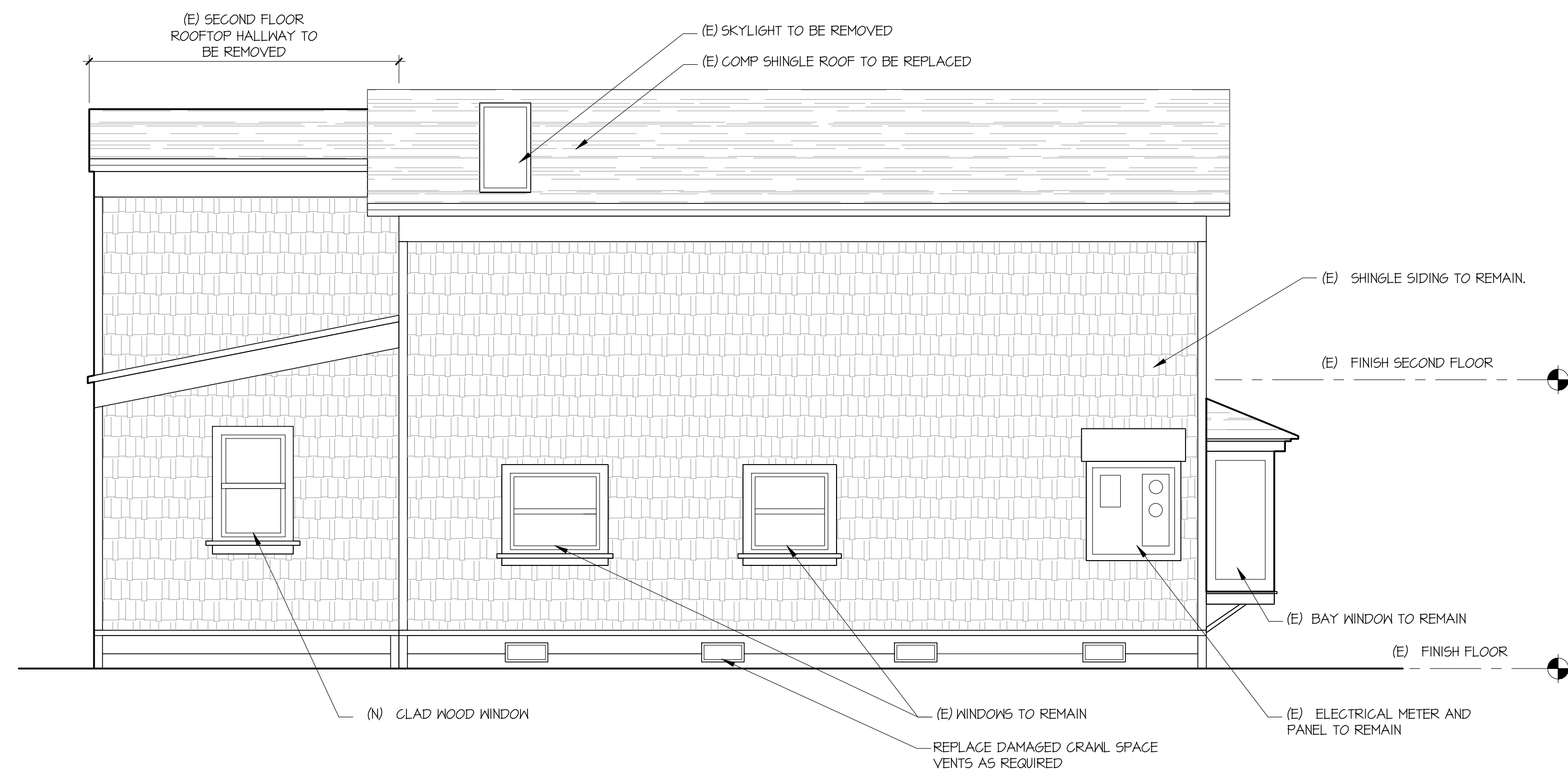

3 EXISTING WEST ELEVATION
1/4"=1'-0"

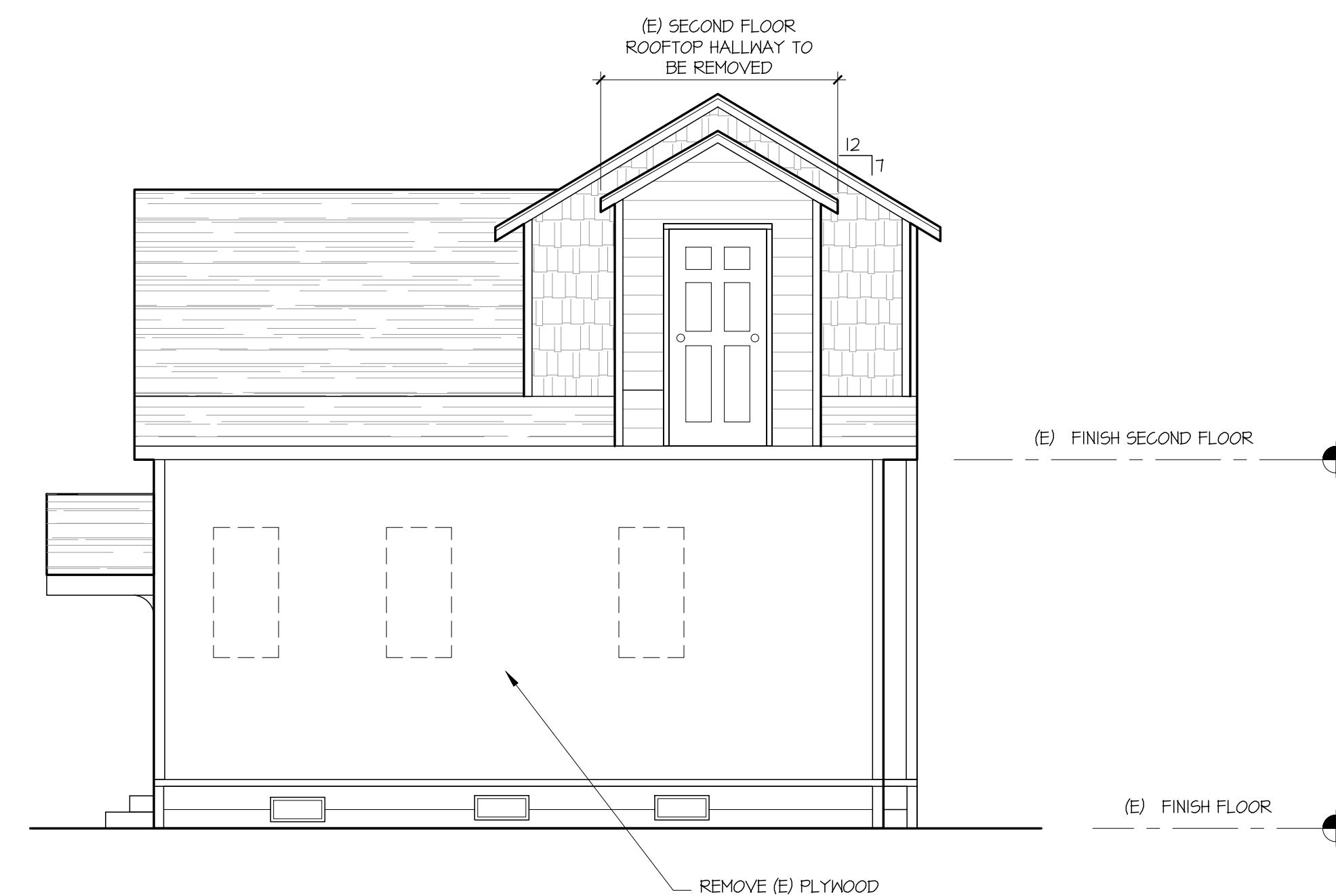

4 EXISTING NORTH ELEVATION
1/4"=1'-0"



Revisions	By

File

RPS DESIGN HEREBY REPRESENTS COMMON LAW COPYRIGHTS AND TRADEMARKS ARE THE PROPERTY OF RPS DESIGN. THESE SERIAL DESIGNS AND PLANS ARE NOT TO BE REPRODUCED, COPIED, OR TRANSMITTED IN ANY FORM OR BY ANY MEANS, WITHOUT THE EXPRESS WRITTEN PERMISSION OF RPS DESIGN. RPS DESIGN WITH DIMENSIONS SHALL HAVE PRECEDENCE OVER ALL OTHER DIMENSIONS AND CONDITIONS OF THE JOB AND THESE PLANS SHALL BE RETURNED UPON REQUEST.

REMODEL TO
349 COLLEGE AVE
SANTA ROSA, CA
APN: 180-750-048

PO BOX 111
LAGUNITAS, CALIFORNIA 94938
(415) 314-0525
rpsuttman@rpsdesign.net

RPS design

EXTERIOR ELEVATIONS

Job No:
Drawn:
Date: 7-20-22

Sheet
A2.0

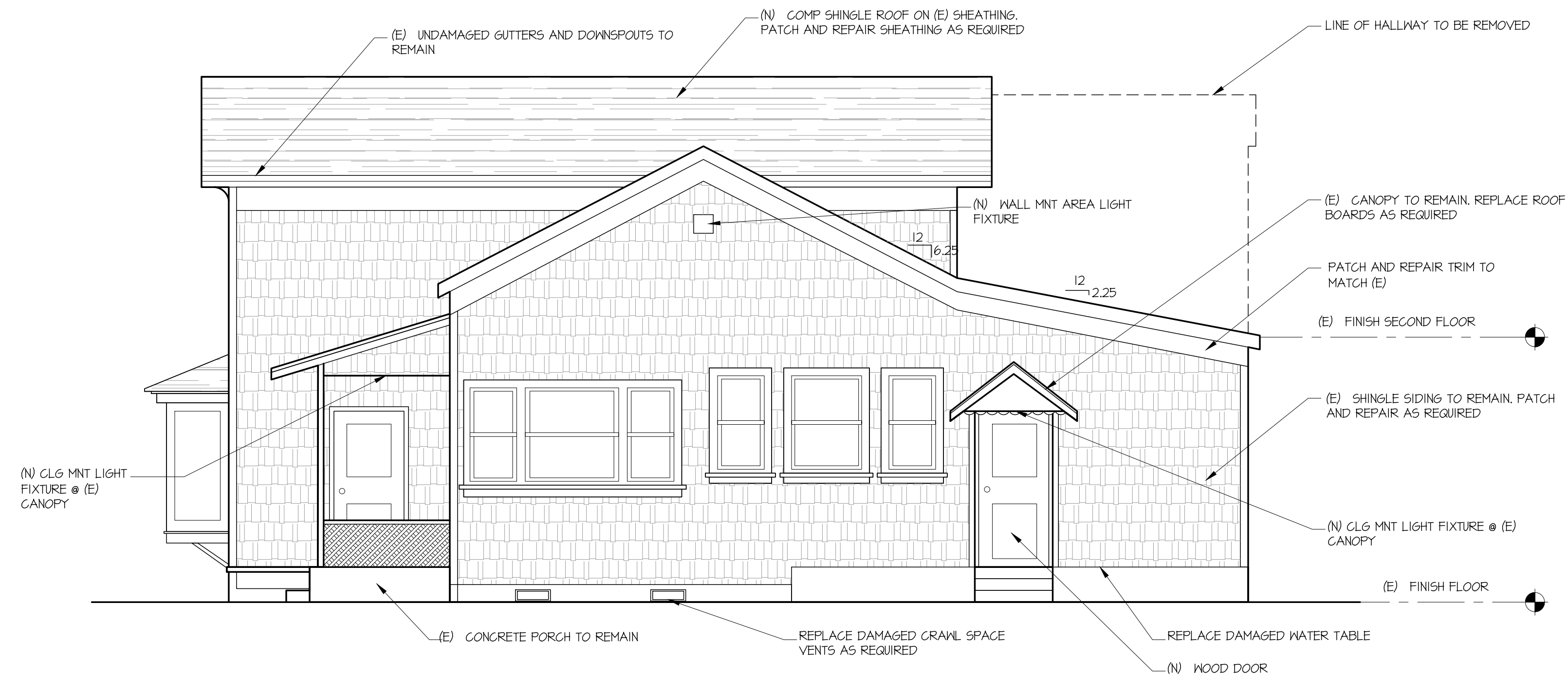

1 PROPOSED EAST ELEVATION
1/4"=1'-0"

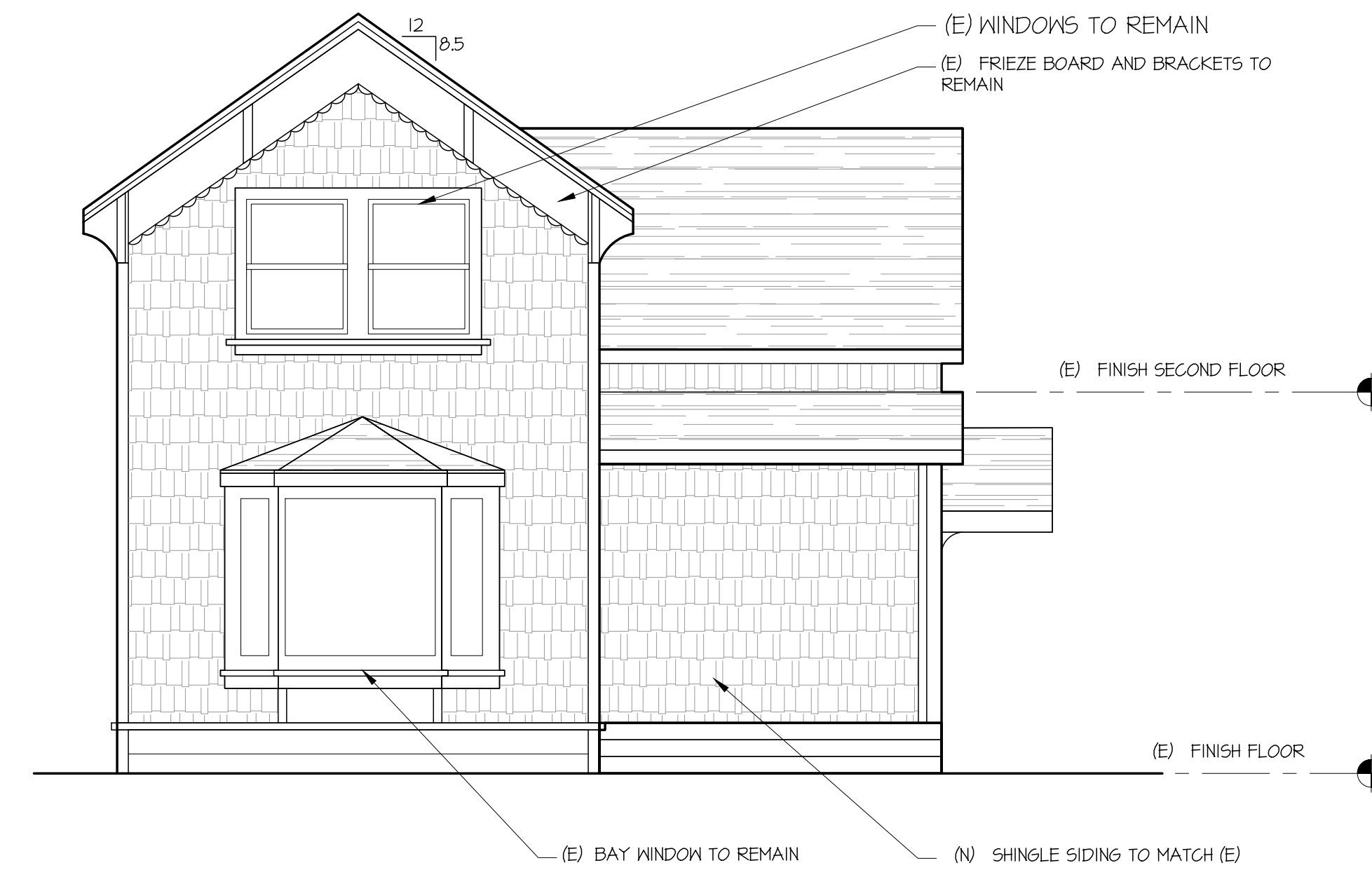

2 PROPOSED SOUTH ELEVATION
1/4"=1'-0"

ELEVATION NOTES:

- PATCH AND REPAIR SHINGLE SIDING AS REQUIRED. SHINGLES TO MATCH EXISTING SHINGLES COLOR, TEXTURE, SIZE AND EXPOSURE.
- REPAIR DAMAGE TO EXISTING WOOD TRIM AS REQUIRED. REPLACE WATER AND FIRE DAMAGED WOOD TRIM AS REQUIRED TO MATCH EXISTING.
- ANY WINDOW TO BE REPLACED AS DICTATED BY BUILDING OR ENERGY CODE SHALL RETAIN THE SAME CONFIGURATION AND DETAILS AS THE ORIGINAL WINDOWS.
- REPLACEMENT WINDOWS SHALL HAVE MOLDED EXTERIOR MUNTINS WHICH REFLECT THE ORIGINAL CONFIGURATION.
- REPLACEMENT WINDOWS SHALL NOT SIGNIFICANTLY ENLARGE OR REDUCE OPENING SIZE.
- REPLACEMENT DOORS SHALL RETAIN THE SAME DETAILS AND CONFIGURATION AS THE ORIGINALS.
- CLEAN EXISTING CEDAR SHINGLES TYP.

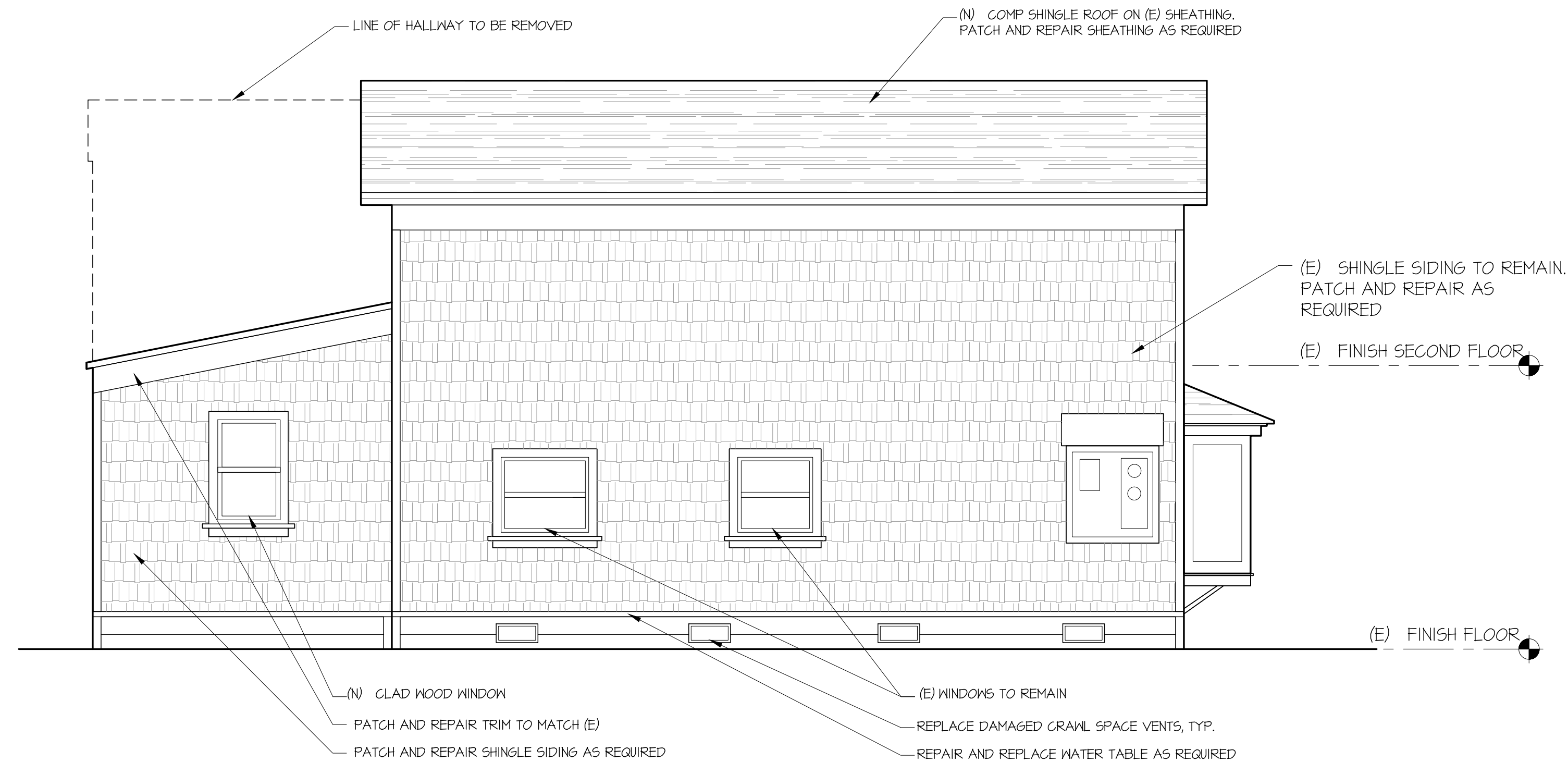

3 PROPOSED WEST ELEVATION
1/4"=1'-0"

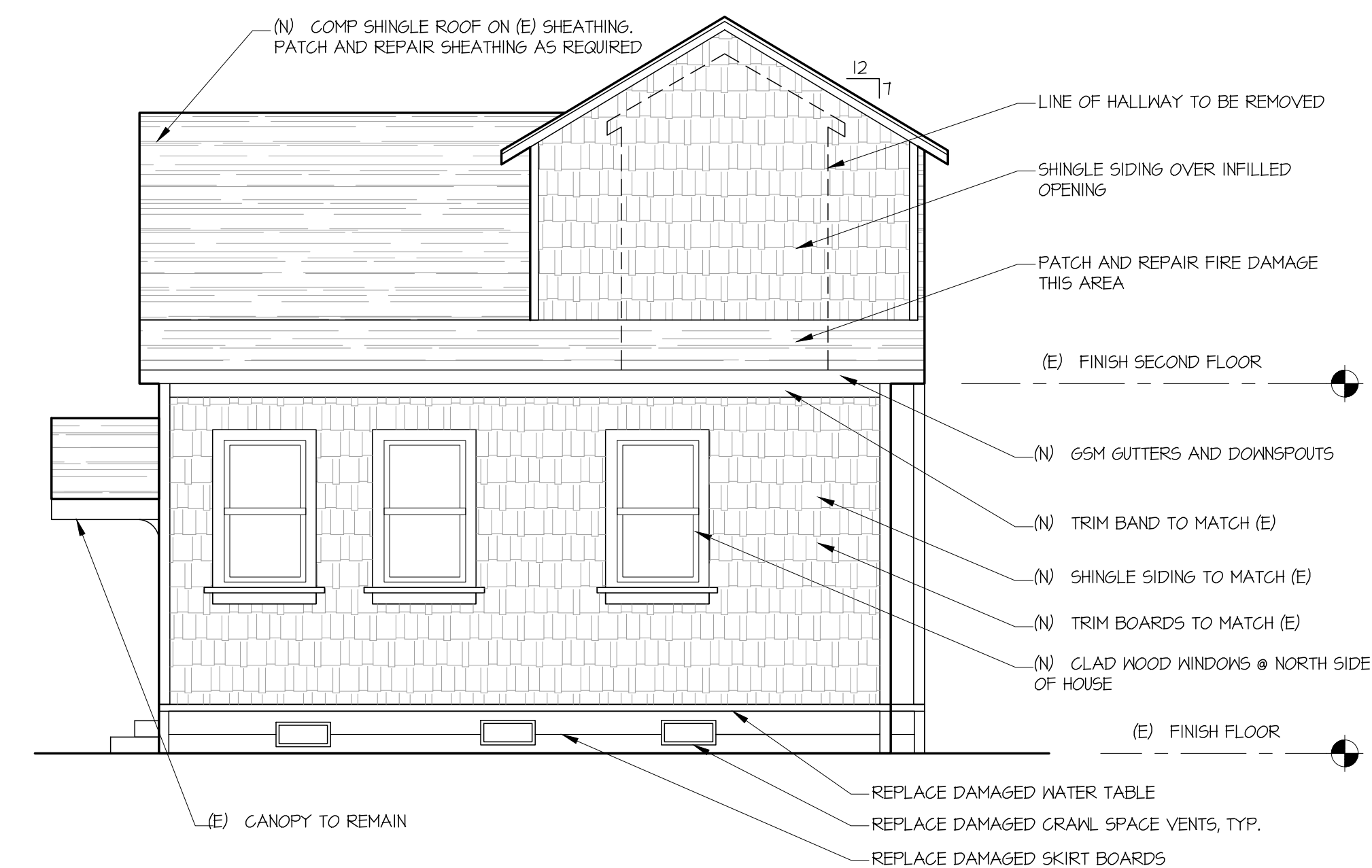

4 PROPOSED NORTH ELEVATION
1/4"=1'-0"

Revisions	By

File

RPS DESIGN HEREBY REPRESENTS COMMON LAW COPYRIGHTS IN THESE ARCHITECTURAL PLANS AND ANY OTHER DESIGN, TRADE DRESS, DESIGN AND PLANS ARE NOT TO BE REPRODUCED, COPIED, EITHER WHOLLY OR IN PART, WITHOUT THE WRITTEN CONSENT OF RPS DESIGN. RPS DESIGN SHALL HAVE PRECEDENCE OVER ANY OTHER DESIGN OR PLANS. THE CLIENT IS RESPONSIBLE FOR OBTAINING ALL NECESSARY PERMITS, CONDITIONS AND REGULATIONS APPLICABLE TO THESE PLANS. THESE PLANS SHALL BE RETURNED UPON REQUEST.

REMODEL TO
349 COLLEGE AVE
SANTA ROSA, CA
APN: 180-750-048

PO BOX 111
LAGUNITAS, CALIFORNIA 94938
(415) 314-0525
rpsuttmann@rpsdesign.net

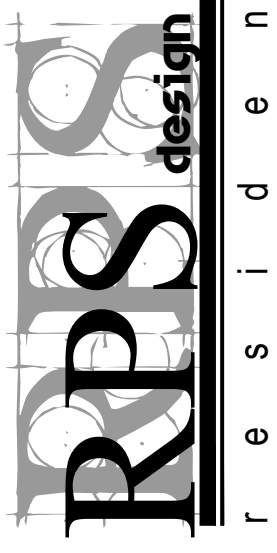

EXTERIOR ELEVATIONS

Job No:
Drawn:
Date: 7-20-22

Sheet
A2.1



SOUTH ELEVATION



SOUTH ELEVATION



WEST ELEVATION



EAST ELEVATION



NORTH ELEVATION

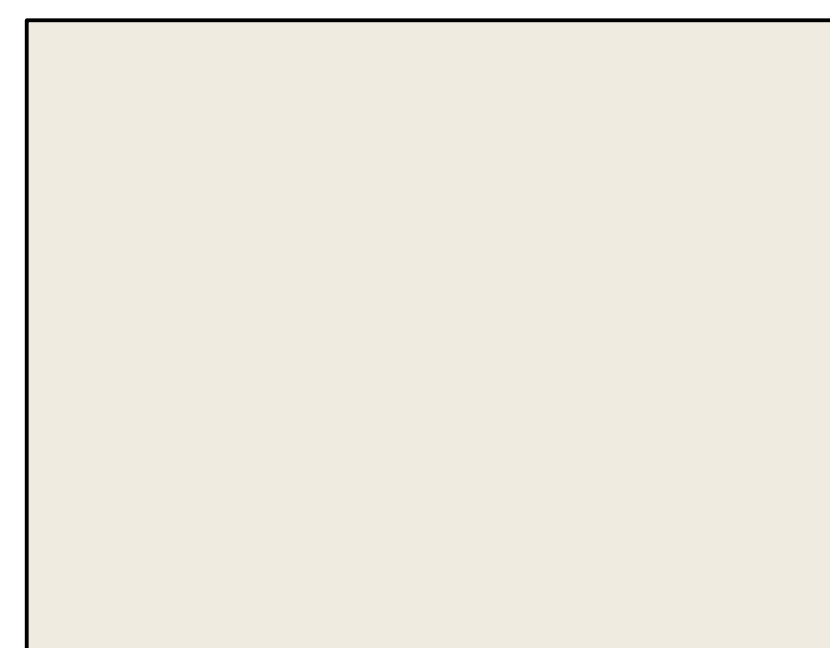

TRIM COLOR - SHERWIN WILLIAMS SHELL WHITE

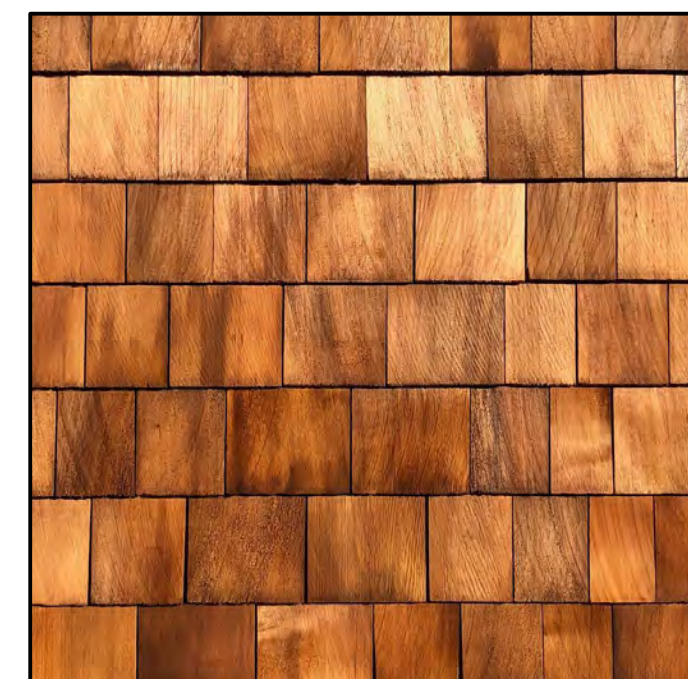

CEDAR SHINGLE SIDING



GRAY ASPHALT SHINGLE ROOF

Revisions	By

File

RPS DESIGN HEREBY REPRESENTS ITS COMMON LAW COPYRIGHTS IN THESE ARCHITECTURAL PLANS AND ANY OTHER DOCUMENTS, THESE ARCHITECTURAL PLANS ARE NOT TO BE REPRODUCED, COPIED, EITHER WHOLLY OR IN PART, WITHOUT THE WRITTEN PERMISSION OF RPS DESIGN. RPS DESIGN SHALL BE RESPONSIBLE FOR THE ACCURACY OF THE INFORMATION CONTAINED HEREIN AND SHALL NOT BE RESPONSIBLE FOR ANY ERRORS OR OMISSIONS. THESE PLANS SHALL BE RETURNED UPON REQUEST.

REMODEL TO
 349 COLLEGE AVE
 SANTA ROSA, CA APN: 180-750-048

PO BOX 111
 LAGUNITAS, CALIFORNIA 94938
 (415) 314-0525
 rpsuttman@rpsdesign.net

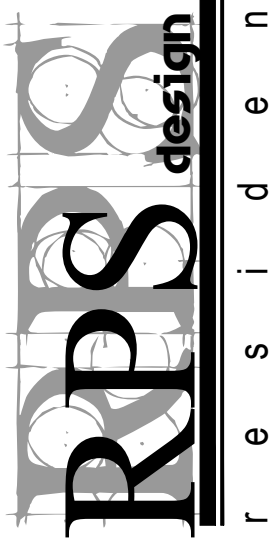

SITE PHOTOS /
 MATERIALS /
 COLORS

Job No:
 Drawn:
 Date: 6-3-22

Sheet

A3.0

TRENTON
EC18705
CEILING

PROJECT

DESCRIPTION
Cast cylindrical aluminum housing and ceiling mount. Finely textured achromatic powder-coat finish. Opal diffuser or transparent optical lens. Down light. Custom options available.



SPECIFICATION DETAILS
* For custom options, consult factory for details.

Fixture Dimensions	D5" x H2"
Light Source	LED
Wattage	15W
Total Lumens	1100lm
Delivered Lumens	BK-824lm, WH-846lm
Voltage	120V
Color Temperature	3000K
CRI (Ra)	>90
Optional Color Temps	2700K - 5000K Available. Minimum Order Quantities Apply
LED Rated Life	50,000 hours
Dimming	100% - 10% ELV Dimmer (Not Included)
Diffuser Details	Frosted Glass Diffuser
Location	Wet
Warranty	5 Years

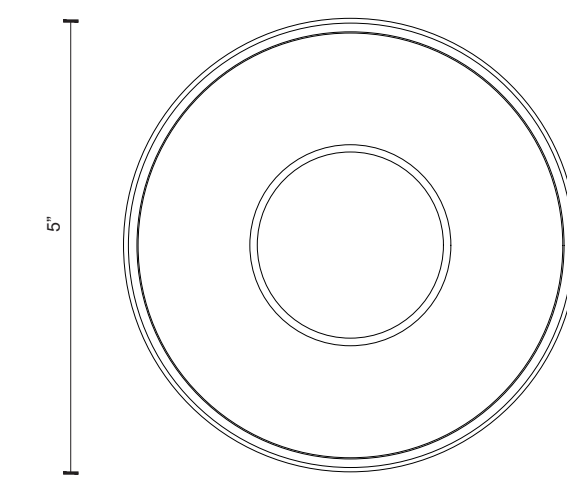
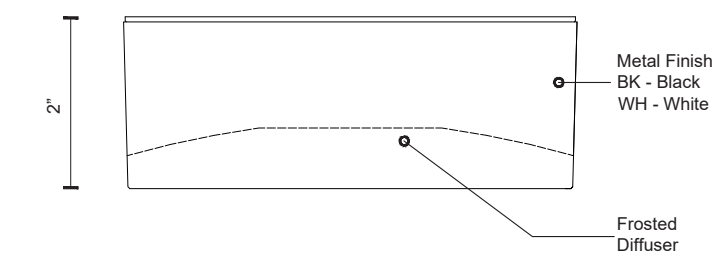

COMMENT

19054 28TH AVENUE
SURREY - BC V3Z 6A3
CANADA
WWW.KLIZCOLIGHTING.COM



PORCH CEILING MOUNTED FIXTURES



PROJECT NAME: _____ CATALOG NUMBER: _____
NOTES: _____ FIXTURE SCHEDULE: _____

Full Cutoff Wall Pack

The Full Cutoff Wall Pack is designed to cast the light down and reduce light spread. It has a tempered glass lens that will resist yellowing over time. It is wet location rated for mounting outside along the sides of buildings, schools, garages and other structures.



- Features:**
- Tempered glass lens, non-yellowing
 - 0-10V dimming standard
 - ETL, DLC Listed
 - IP65 Rated
 - 120-277V
 - CRI: >70
 - CCT: 4000K or 5000K
 - Life: 50000 Hours
 - Warranty: 5 Years
 - Lumens:
 - o 45W = 5500
 - o 60W = 6900
 - o 75W = 8800
 - o 90W = 11000
- Applications**
- Building façade
 - Carports
 - Loading areas
 - Driveways
 - Parking areas

WareLight Full Cutoff Wall Pack				
Model	Wattage	CCT	Voltage	Generation
WLFC	45W	4000K	MV (120-277V)	G2
	60W	5000K		
	75W			
	90W			

Dimensions
Length: 13" (330mm)
Width: 11.25" (280mm)
Height: 9.25" (230mm)

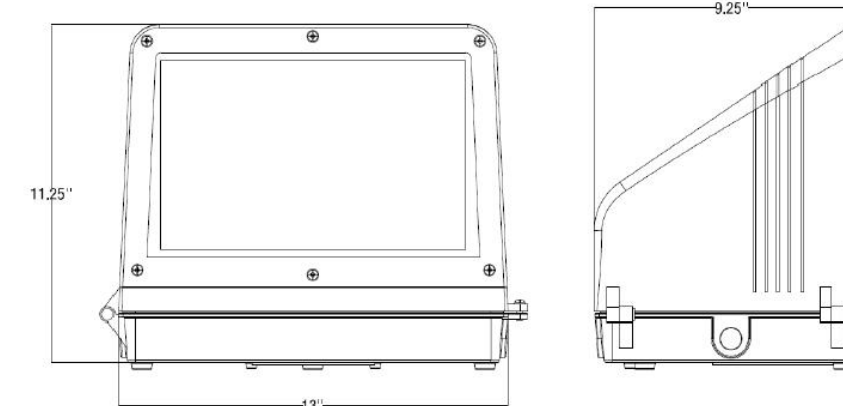

Warehouse-Lighting.com
2750 South 163rd St
New Berlin, WI 53151

Warehouse-Lighting.com
Phone: 888-454-4480
info@warehouse-lighting.com

EXTERIOR WALL MOUNTED AREA LIGHT FIXTURES

Revisions	By

File

RPS DESIGN HEREBY RESERVES ITS COMMON LAW COPYRIGHTS IN ALL ORIGINAL WORKS OF ART AND DESIGN. THESE ORIGINAL DESIGNS AND PLANS ARE NOT TO BE REPRODUCED, COPIED, EITHER WHOLLY OR IN PART, OR TRANSMITTED IN ANY FORM OR BY ANY MEANS, WITHOUT THE WRITTEN PERMISSION OF RPS DESIGN. RPS DESIGN SHALL HAVE PRIORITY AND RESPONSIBILITY FOR THE PROTECTION OF THESE ORIGINAL DESIGNS AND PLANS. RPS DESIGN SHALL BE RESPONSIBLE FOR THE PROTECTION OF THESE ORIGINAL DESIGNS AND PLANS. THESE PLANS SHALL BE RETURNED UPON REQUEST.

REMODEL TO
349 COLLEGE AVE
SANTA ROSA, CA
APN: 180-750-048

PO BOX 111
LAGUNITAS, CALIFORNIA 94938
(415) 314-0525
rpsdesign.net
rpsdesign.net

RPS design

LIGHTING CUT SHEETS

Job No:
Drawn:
Date: 7-20-22

Sheet
A4.0