

Regional Operations Update

Subregional Technical Advisory
Committee

November 7, 2024

Mike Prinz

Deputy Director

Regional Water Reuse Operations



Topics for Today

- Recycled Water Production and Storage
- Calpine Contract and Agricultural Irrigation Status
- On-call Construction Efforts
- Headworks Seismic HMGP Update
- Disinfection System Upgrade Status

Recycled Water Production

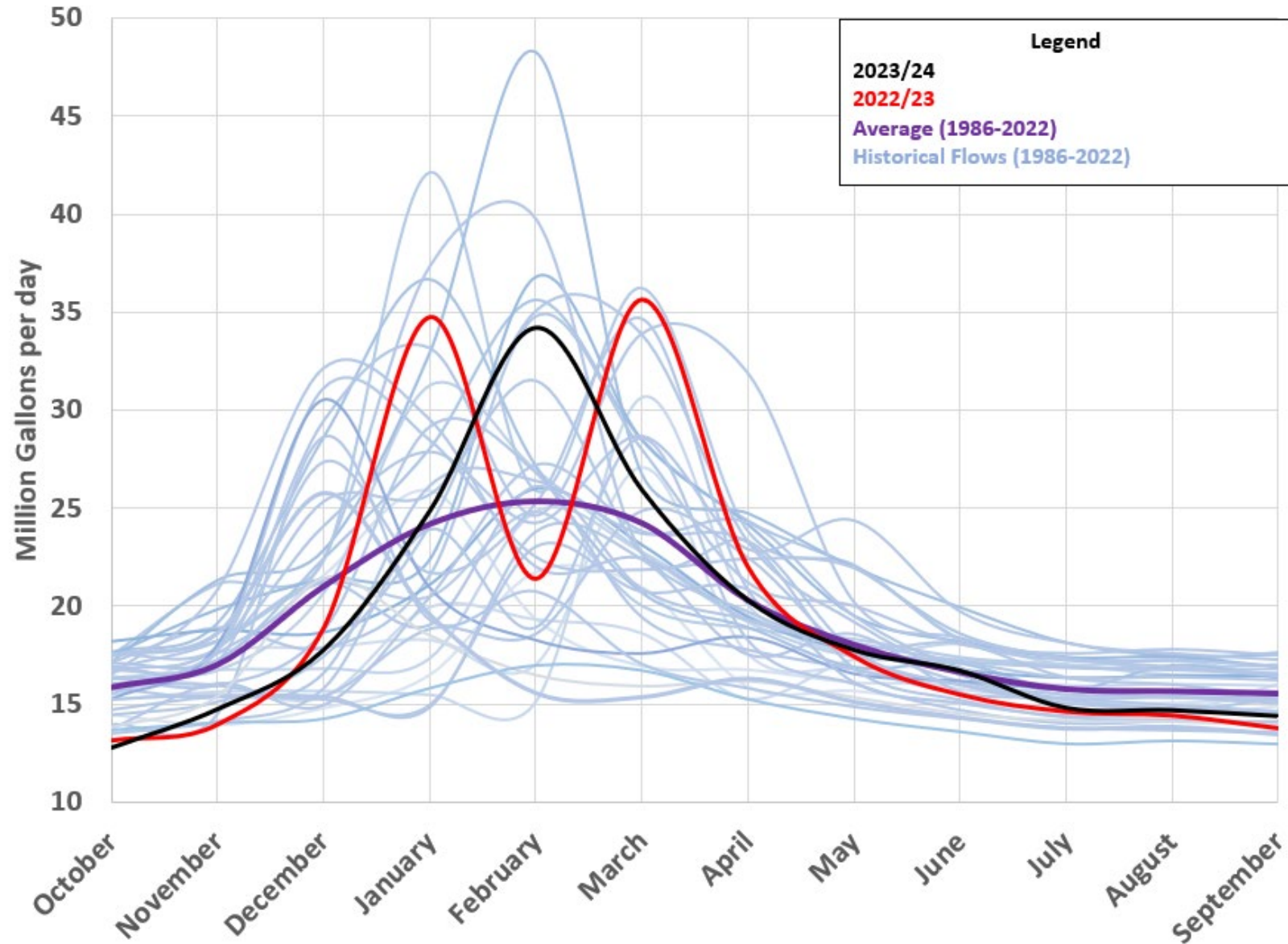

Current Recycled Water Storage

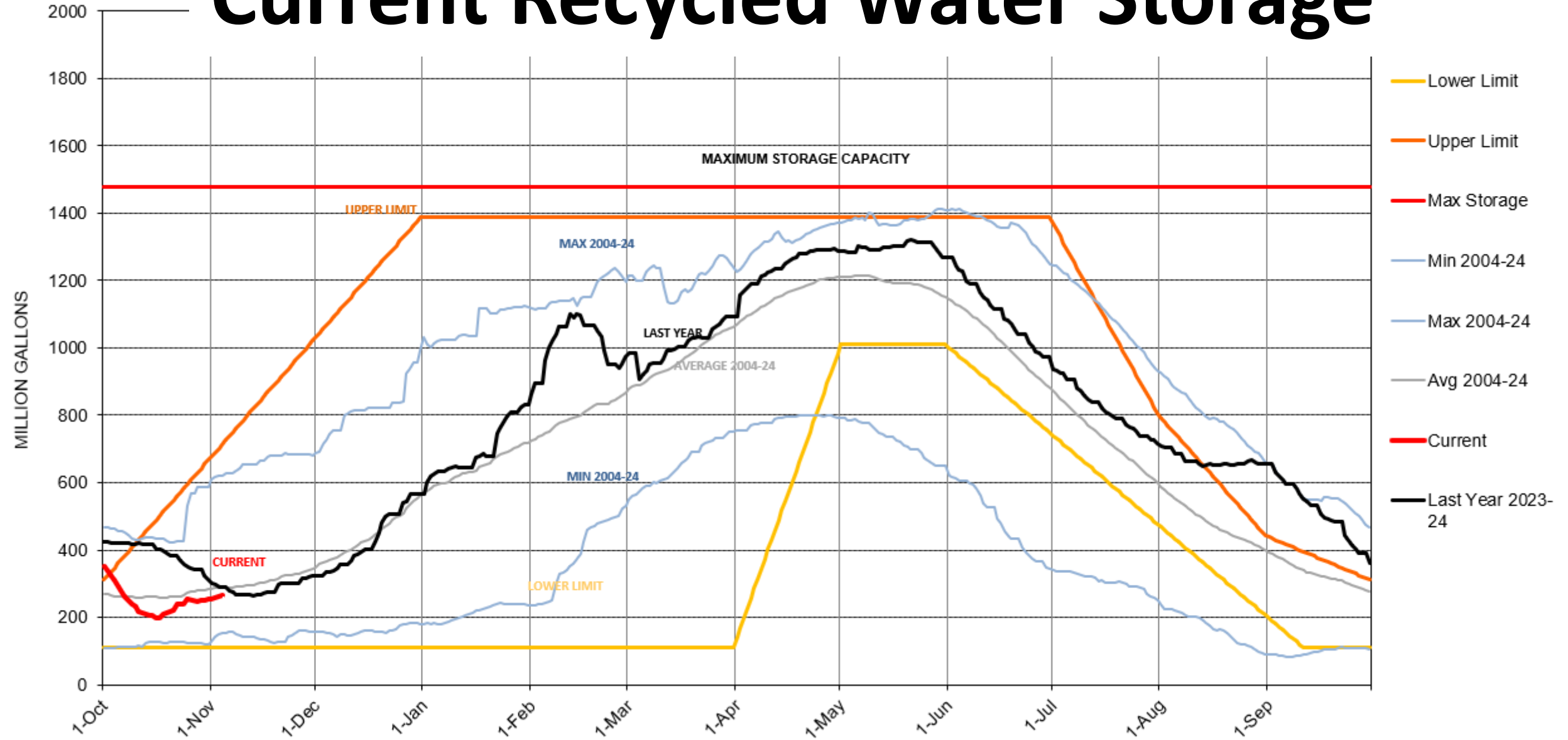

Calpine Delivery and Agricultural Irrigation Status

- Calpine Contract Fulfillment
 - 90% (minimum) by November 11
 - 115% possible by December 31
- 2024 Agricultural Allotment: 1.4 BG
 - 73% usage as of September 30 (end of season)
 - Irrigation allowed to October 25
 - 190 MG irrigated on City Farms – 3 cuttings

On-call Construction Efforts













2024-10-09 22:34:15



2024-10-08 20:10:14











Loss of LTP
Function
~~\$60/day~~
\$66/day

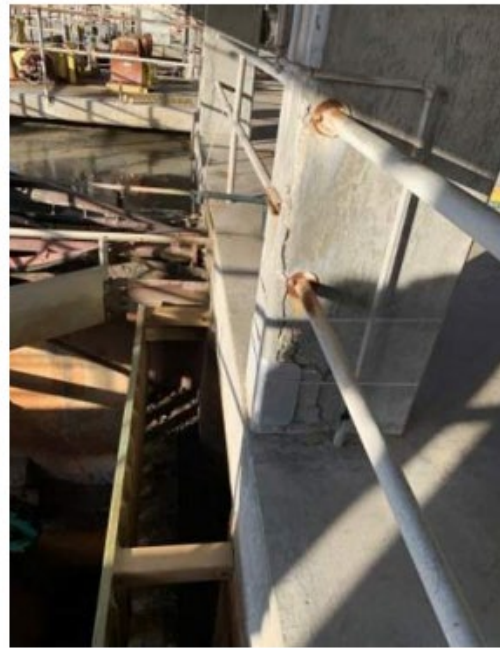

Column Spalling



FEMA

~~\$13.8M~~
\$15.2M
per day!

Hazard Mitigation
Grant Program
(HMGP)

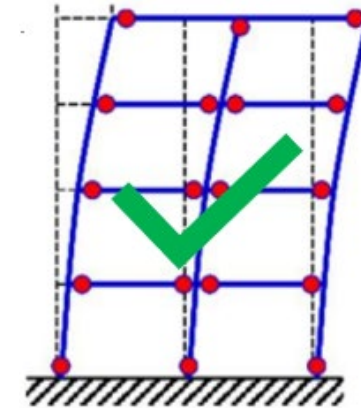

(a) Global failure mechanism

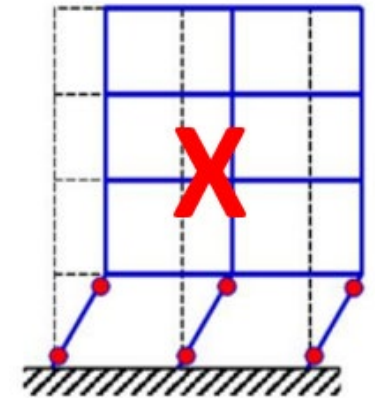

(b) Local failure mechanism

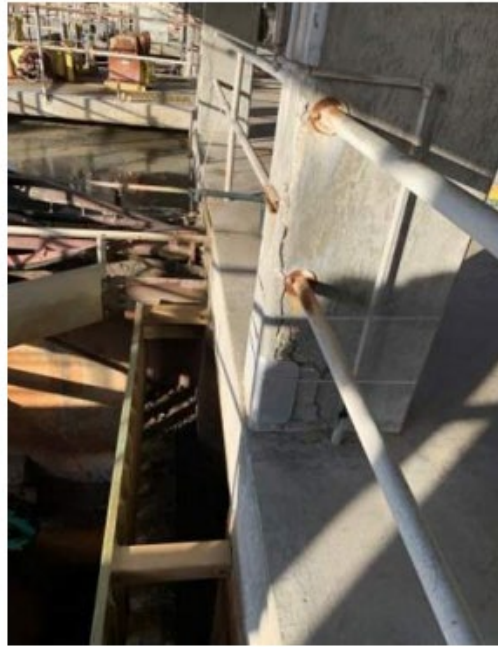

Column Spalling



FEMA

BCR of 34.1

Hazard Mitigation
Grant Program
(HMGP)

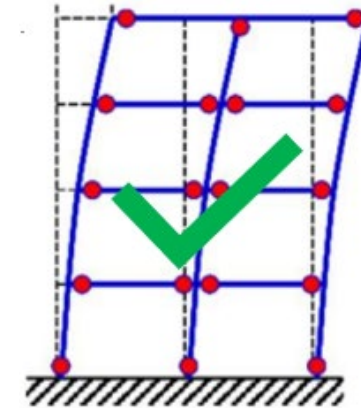

(a) Global failure mechanism

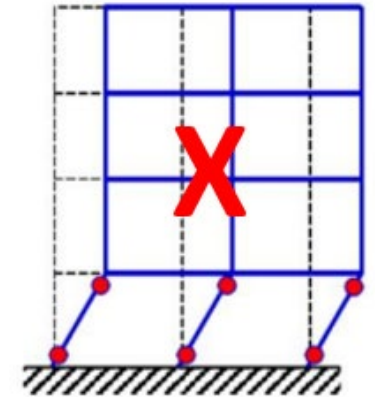

(b) Local failure mechanism



UV Construction Update

- Diversion Wet Well – done
- Bypass installed and active
 - Effluent Channel – south half
- Electrical Underground - done
- Electrical Load Center Building
- Influent Channel Done
- Treatment Channels Done
- Planning for Startup and Testing

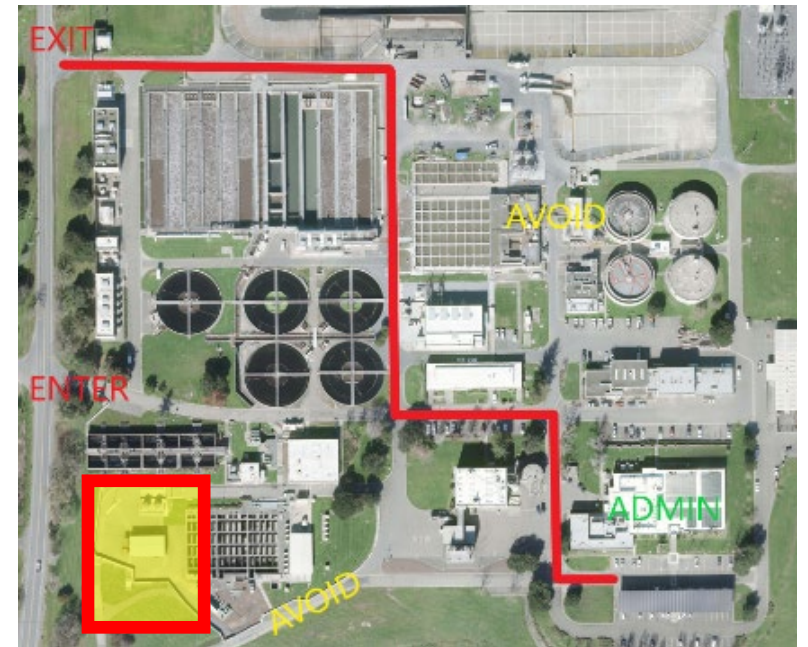

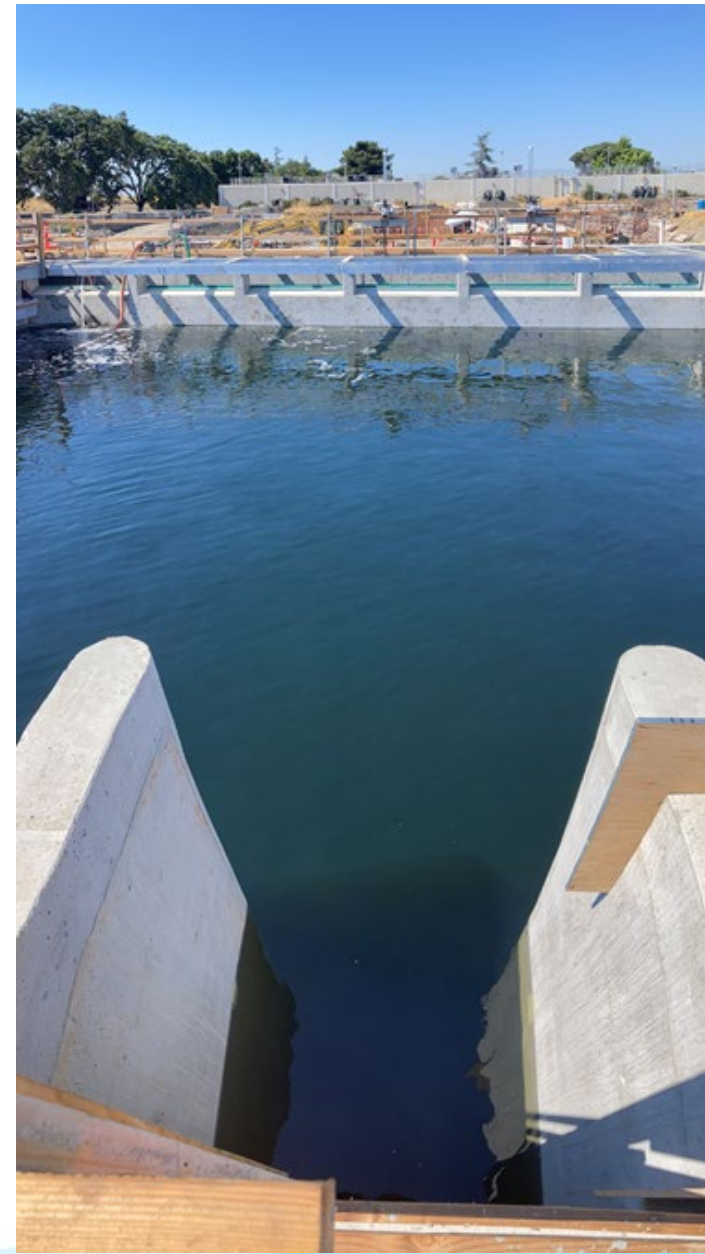

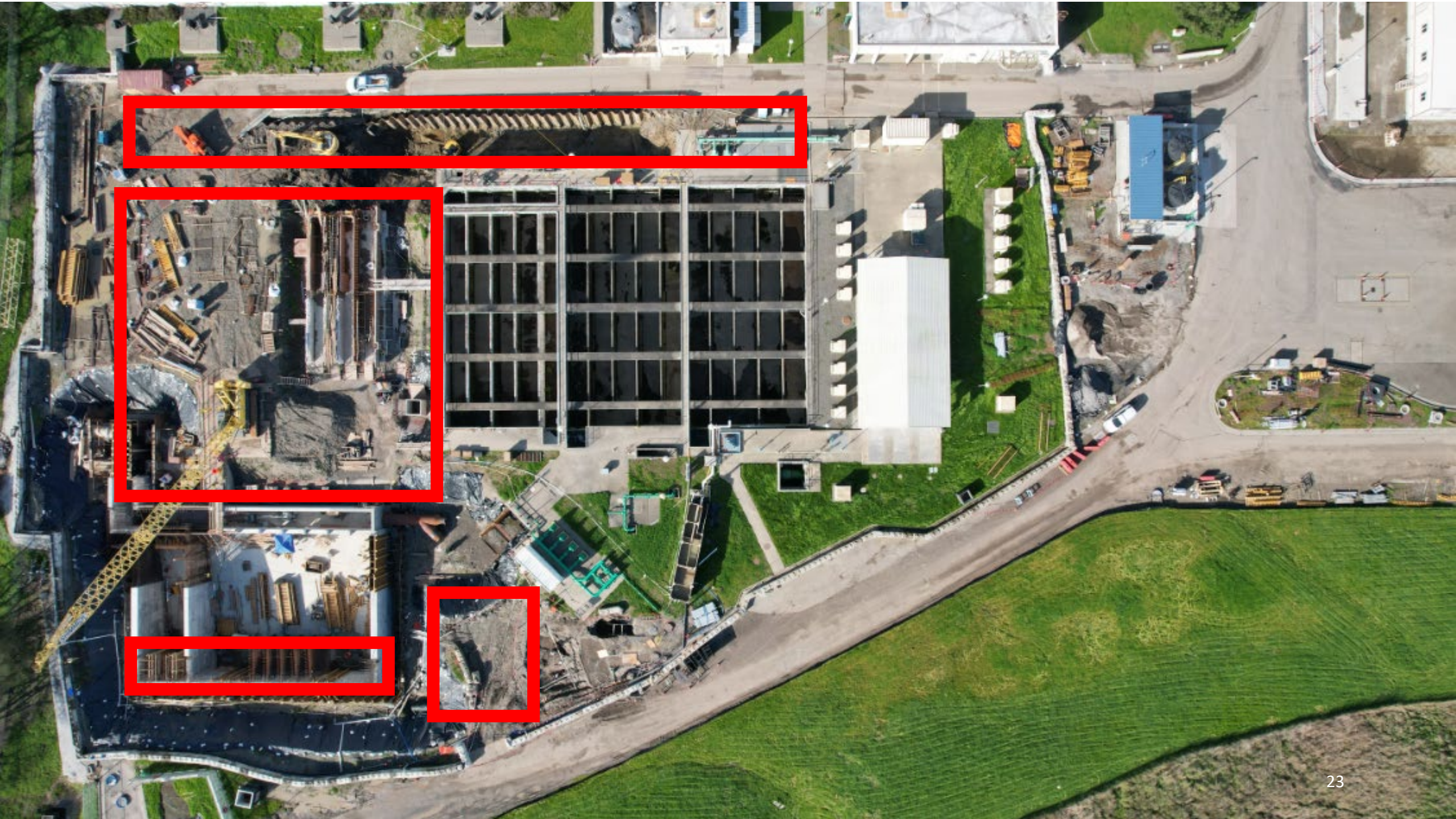





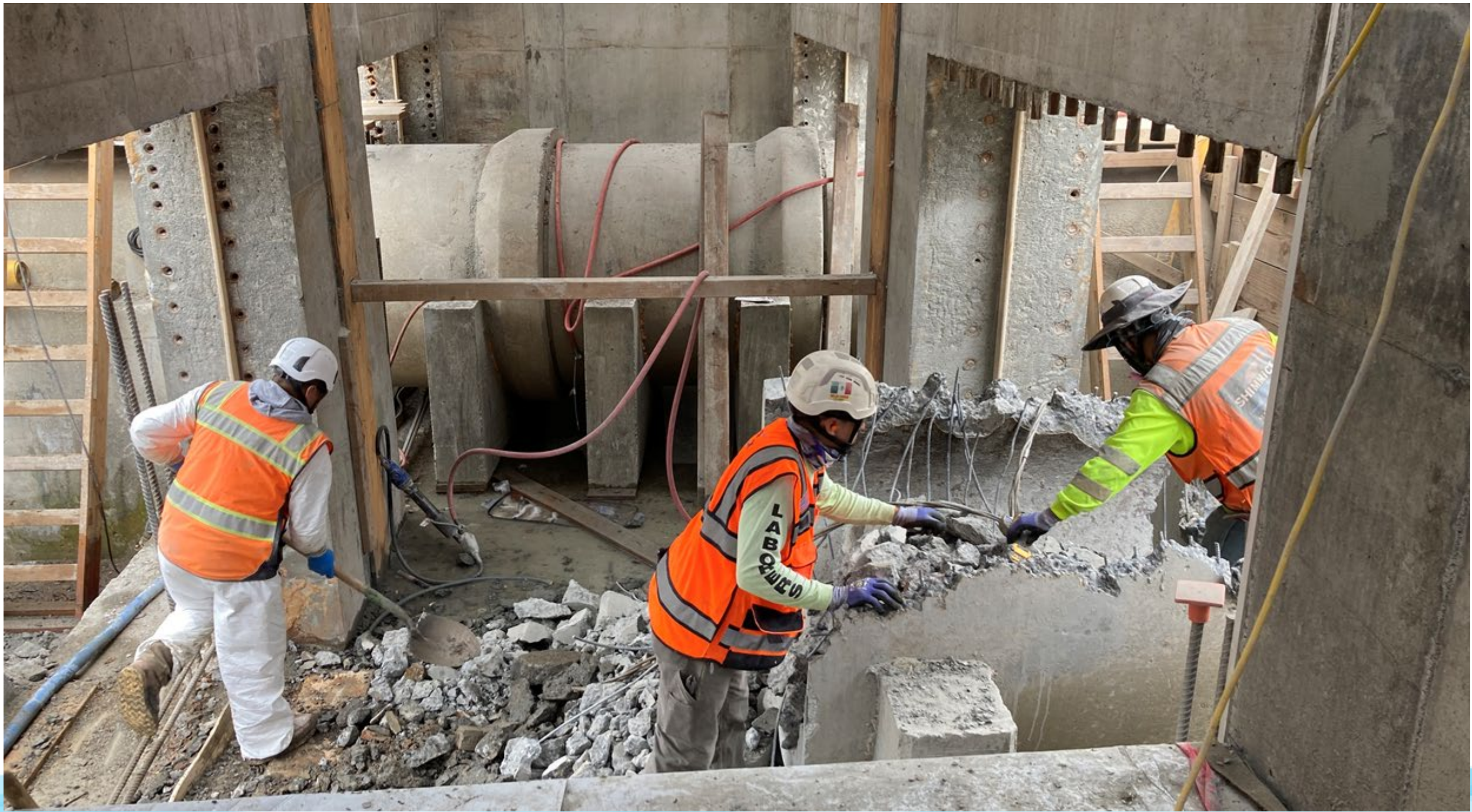









08/01/2024



08/16/2024



08/29/2024









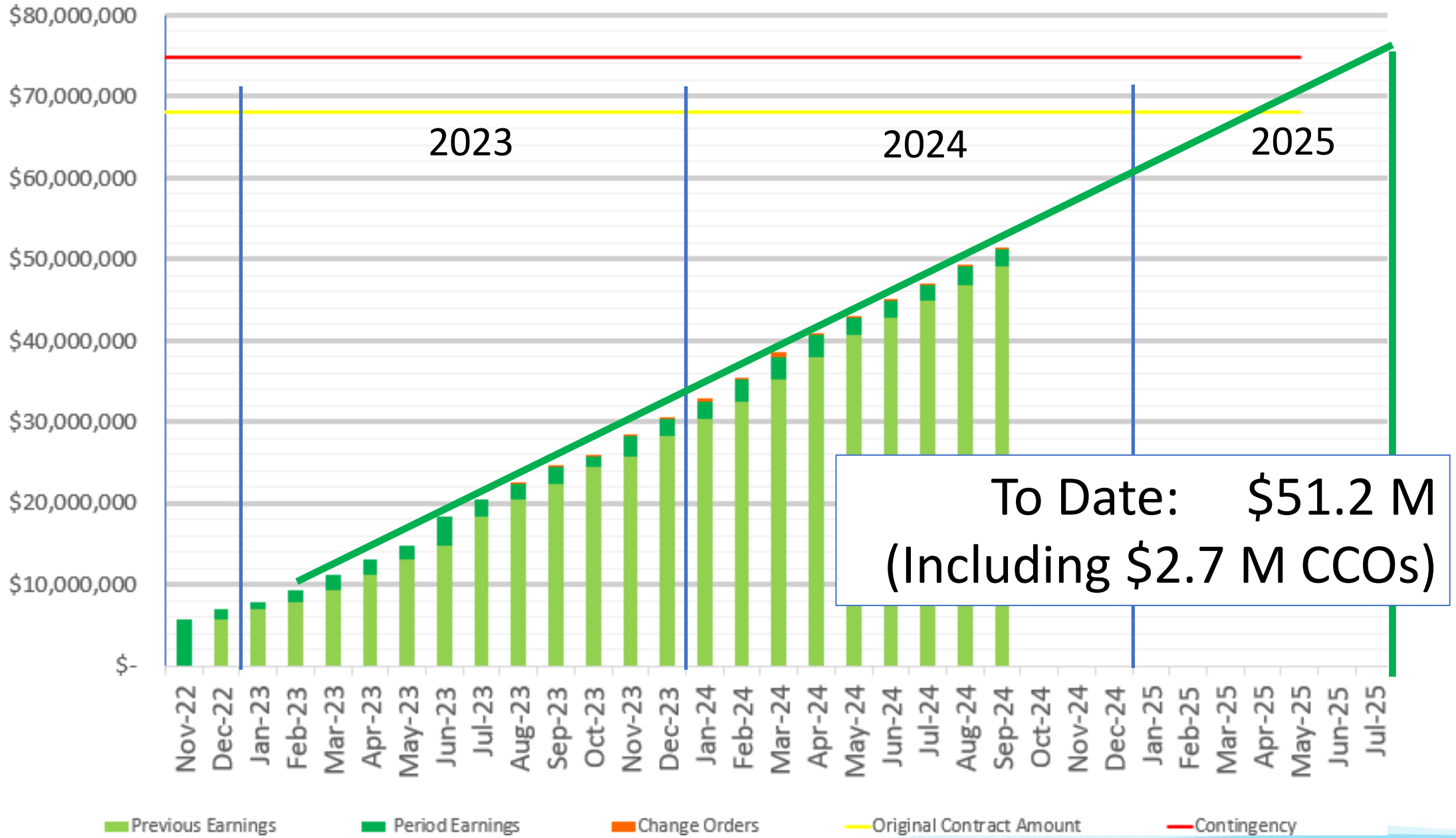

Cost/Schedule Summary

Days Remaining	242
Working Days Elapsed	77.5%
Contract Paid to date	53.4%
Contingency Used	39.6%
Notice To Proceed	6/20/2022
Final Completion	5/30/2025

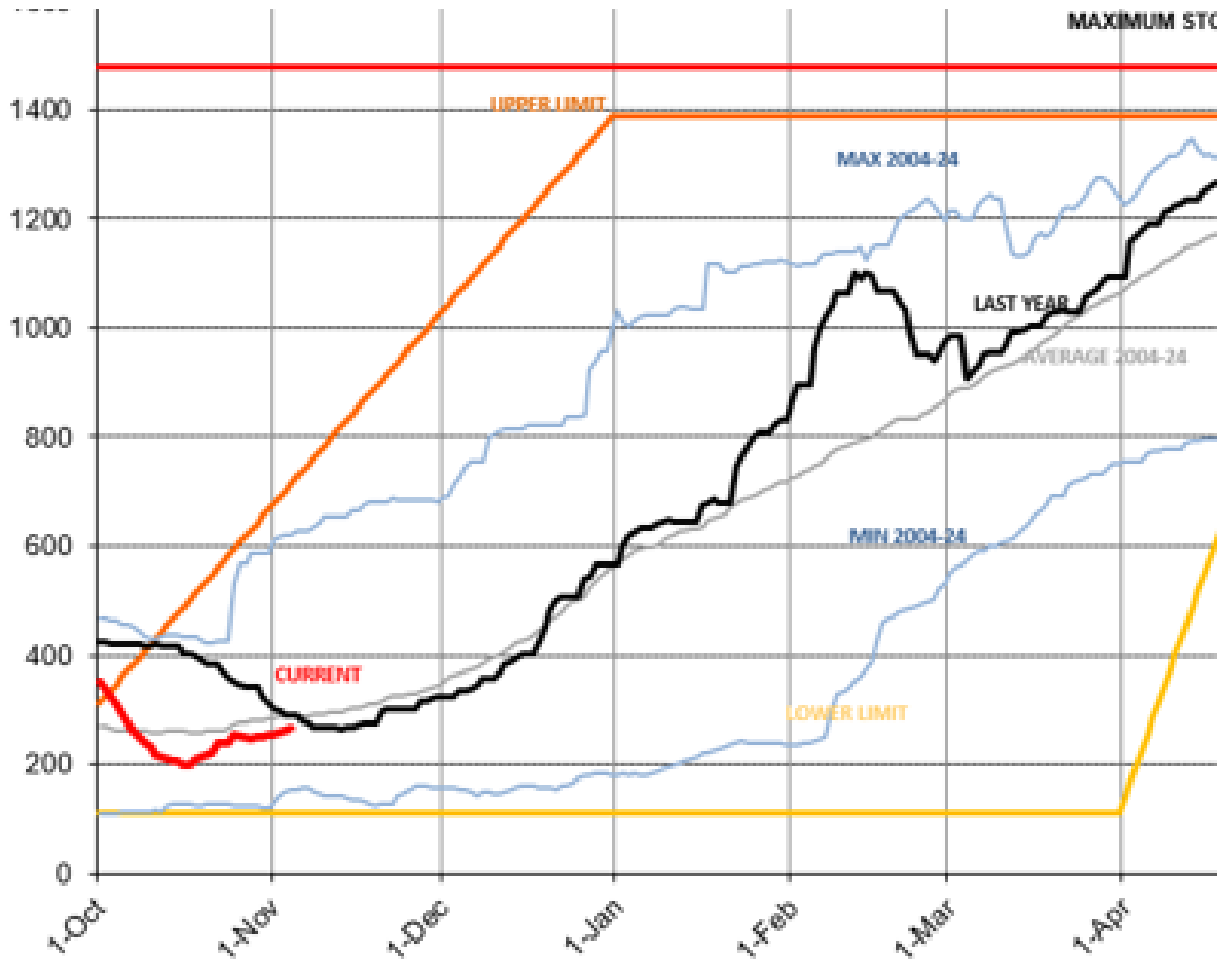

Questions?