

SECTION A
NO SCALE

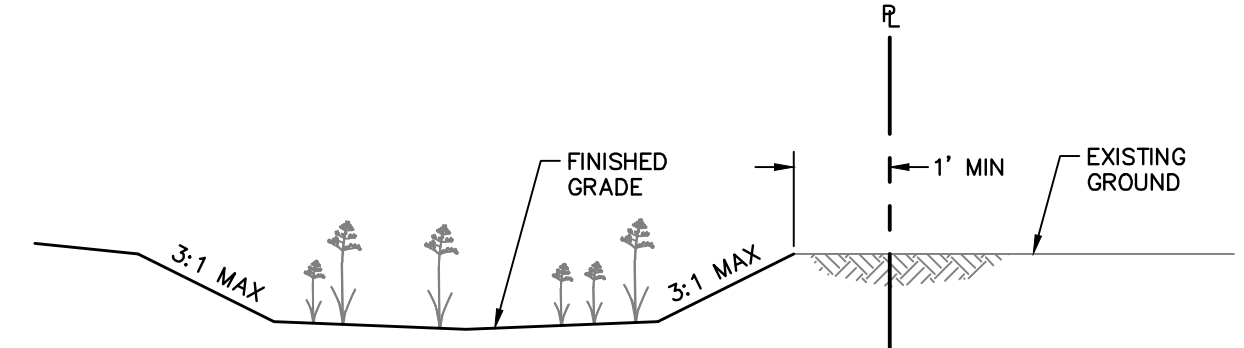

SECTION B
NO SCALE

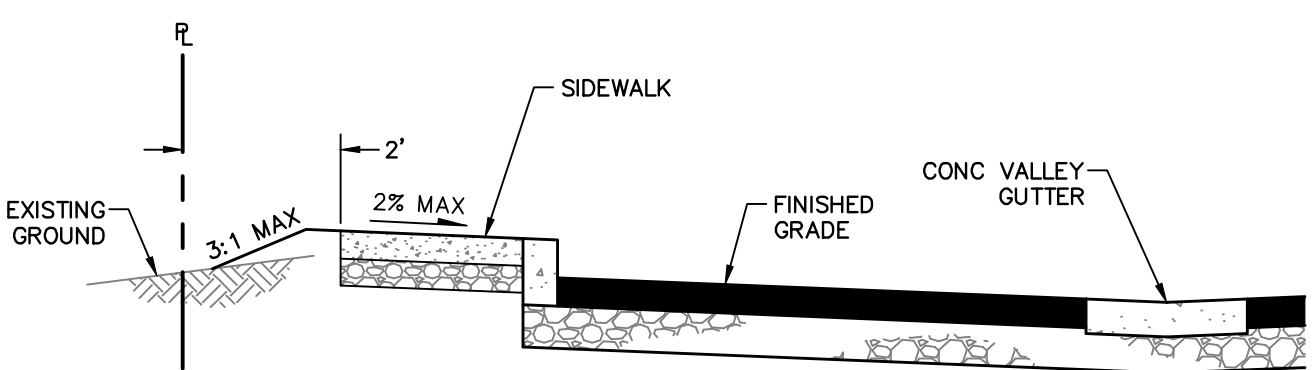

SECTION C
NO SCALE

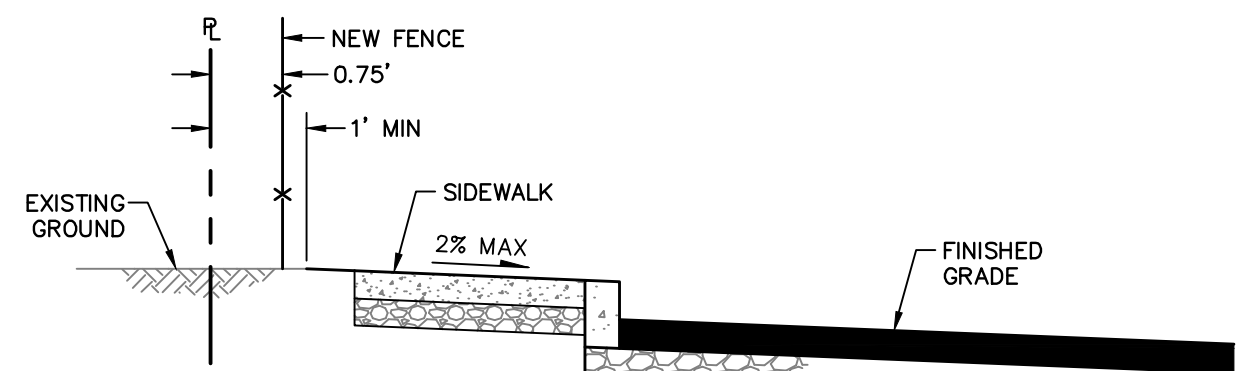

SECTION D
NO SCALE

NOTE: SEE SHEET 3 FOR TYPICAL STREET SECTIONS.

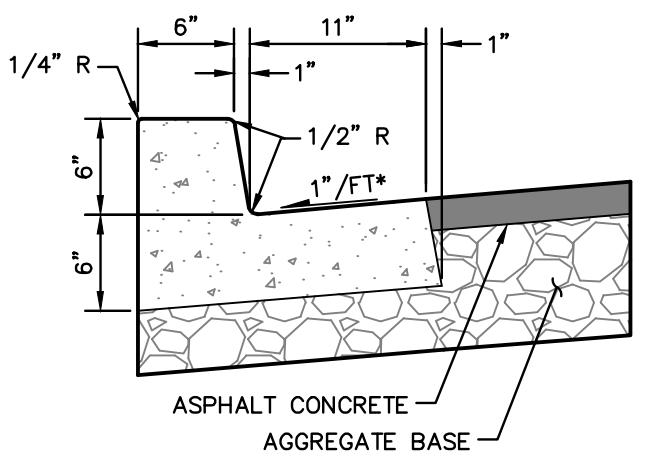

CURB DETAIL
NO SCALE

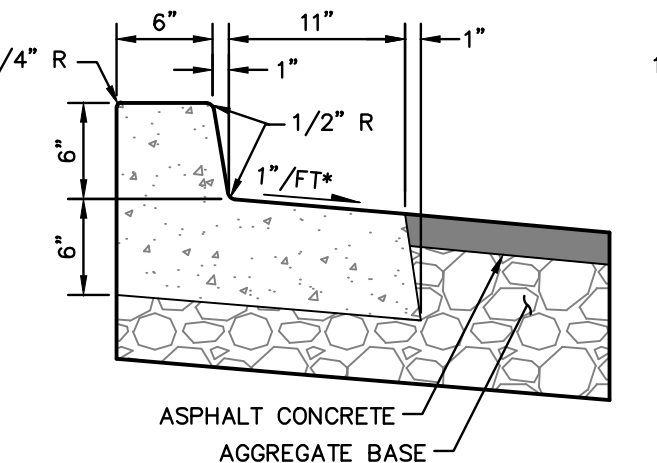

CURB DETAIL
NO SCALE

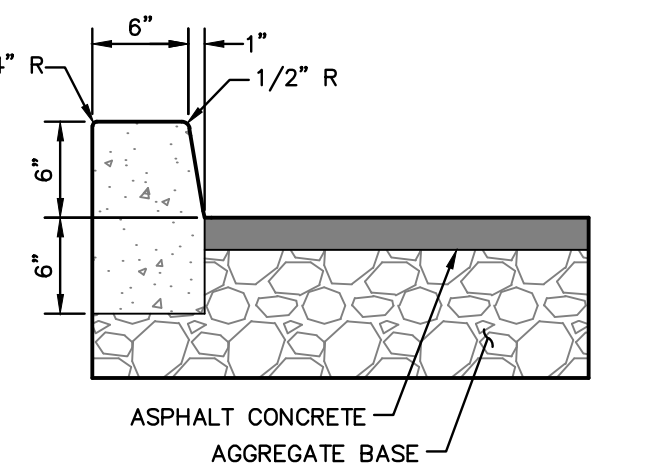

CURB DETAIL
NO SCALE

* GUTTER PAN SLOPE NOT TO EXCEED 2% IN ACCESSIBLE AREAS WHERE CURB AND GUTTER ARE PERPENDICULAR TO A CONCRETE SURFACE, GUTTER SLOPE SHALL CONFORM TO ADJACENT CONCRETE SLOPE.

REFER TO THE LANDSCAPE ARCHITECTS DRAWINGS FOR PLANTING.

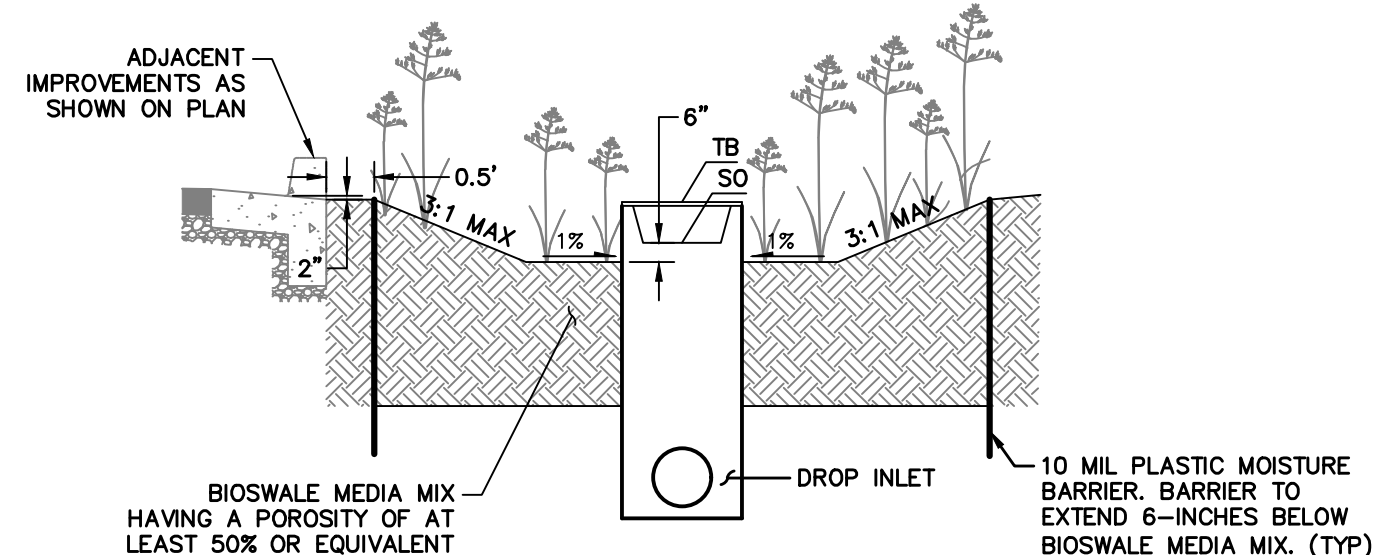

VOLUME CAPTURE FACILITY
NO SCALE

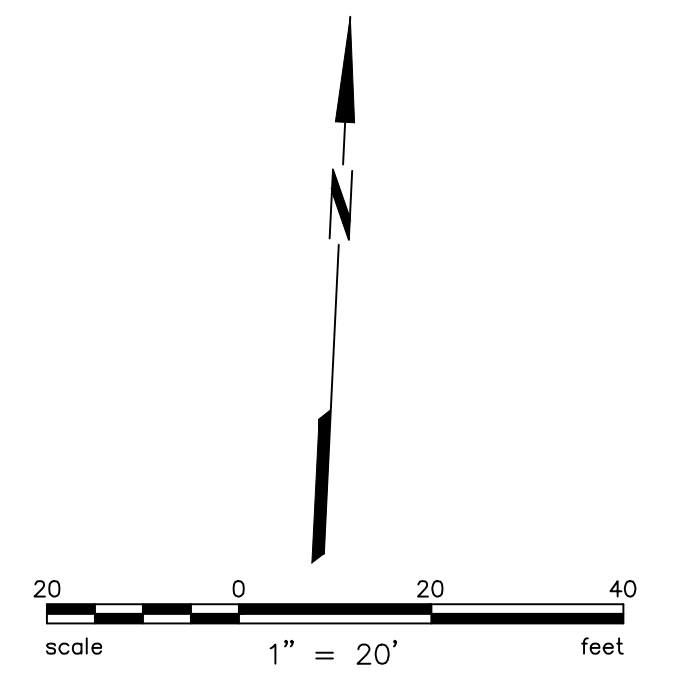

TENTATIVE MAP FOR HEARN VETERANS VILLAGE GRADING SHEET

4 MULTIFAMILY RESIDENTIAL LOTS

BEING A RE-SUBDIVISION OF LOT 1, AND PORTIONS OF LOTS 2 & 3 AS SHOWN ON THE FINAL MAP OF VOLKERTS HOMESITES, FILED IN BOOK 57 OF MAPS AT PAGES 25 & 26, SONOMA COUNTY RECORDS, ALSO BEING THE LANDS OF COMMUNITY HOUSING SONOMA COUNTY, A CALIFORNIA NONPROFIT PUBLIC BENEFIT CORPORATION, AS DESCRIBED IN DOCUMENT NO. 2008-013240 & 2009-069547, SONOMA COUNTY RECORDS.

2149 WEST HEARN AVENUE
CITY OF SANTA ROSA, CALIFORNIA
APN 134-011-012 AND 013
CONTAINING 3.05 ACRES
MAY 2021

PREPARED BY
BKF
200 4th STREET
SUITE 300
SANTA ROSA, CA 95401
(707) 583-8500
www.bkf.com

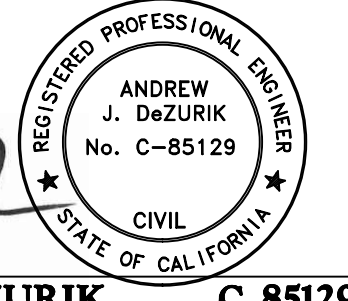

05/04/2021
ANDREW J. DEZURIK
C 85129

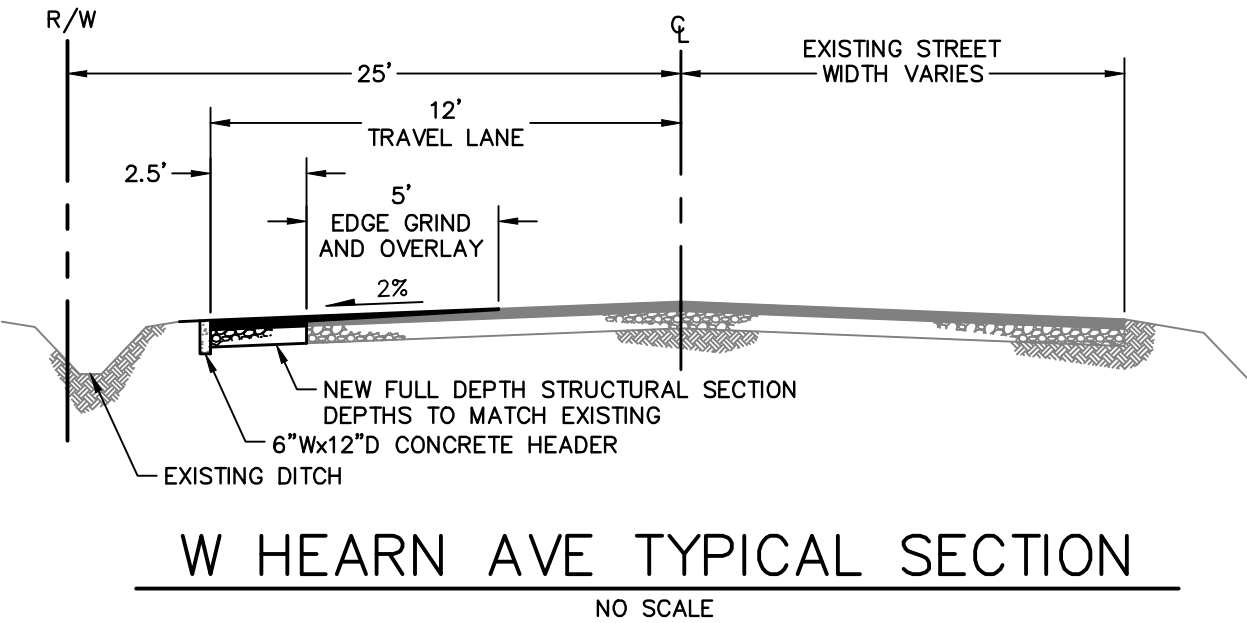
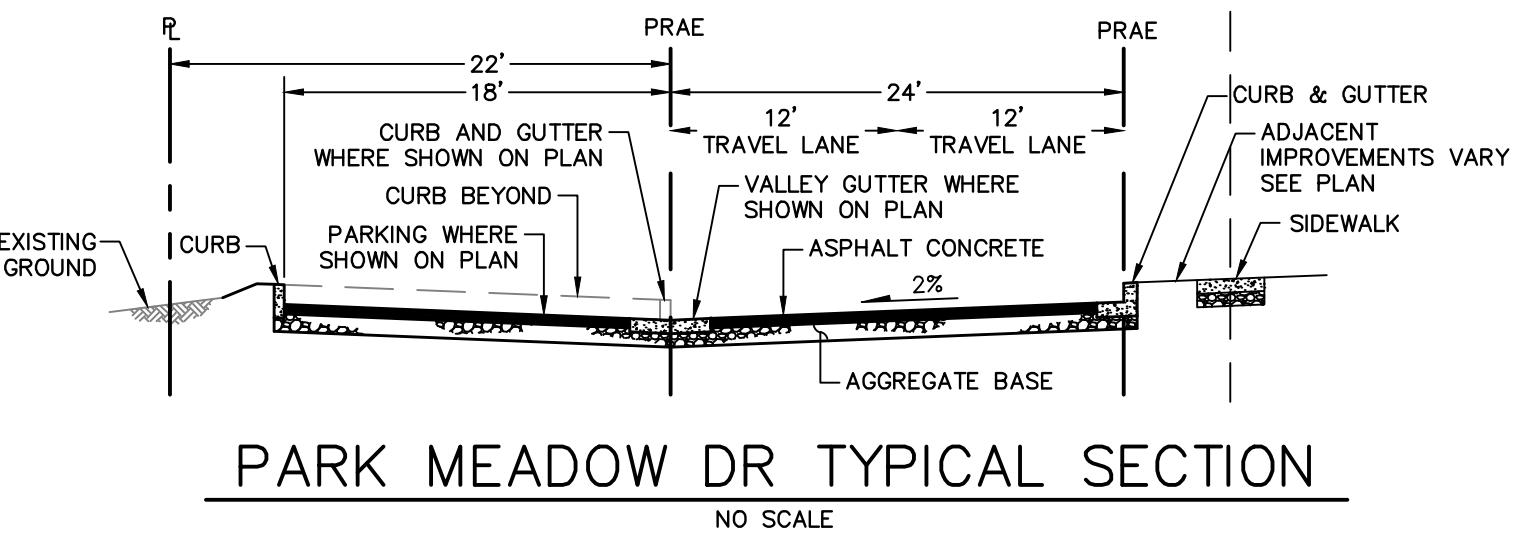
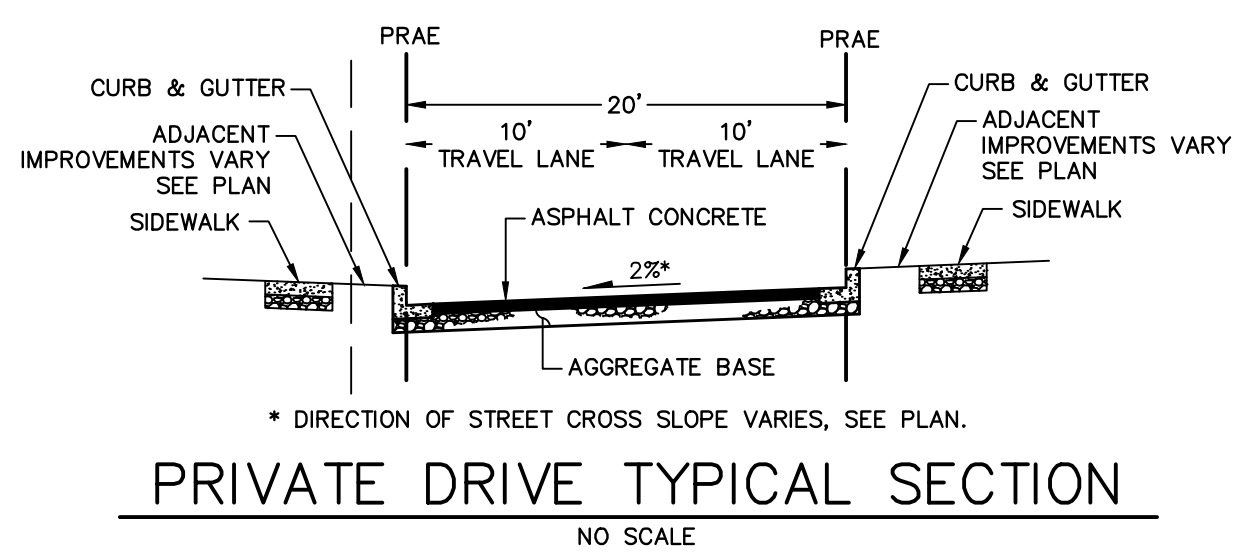
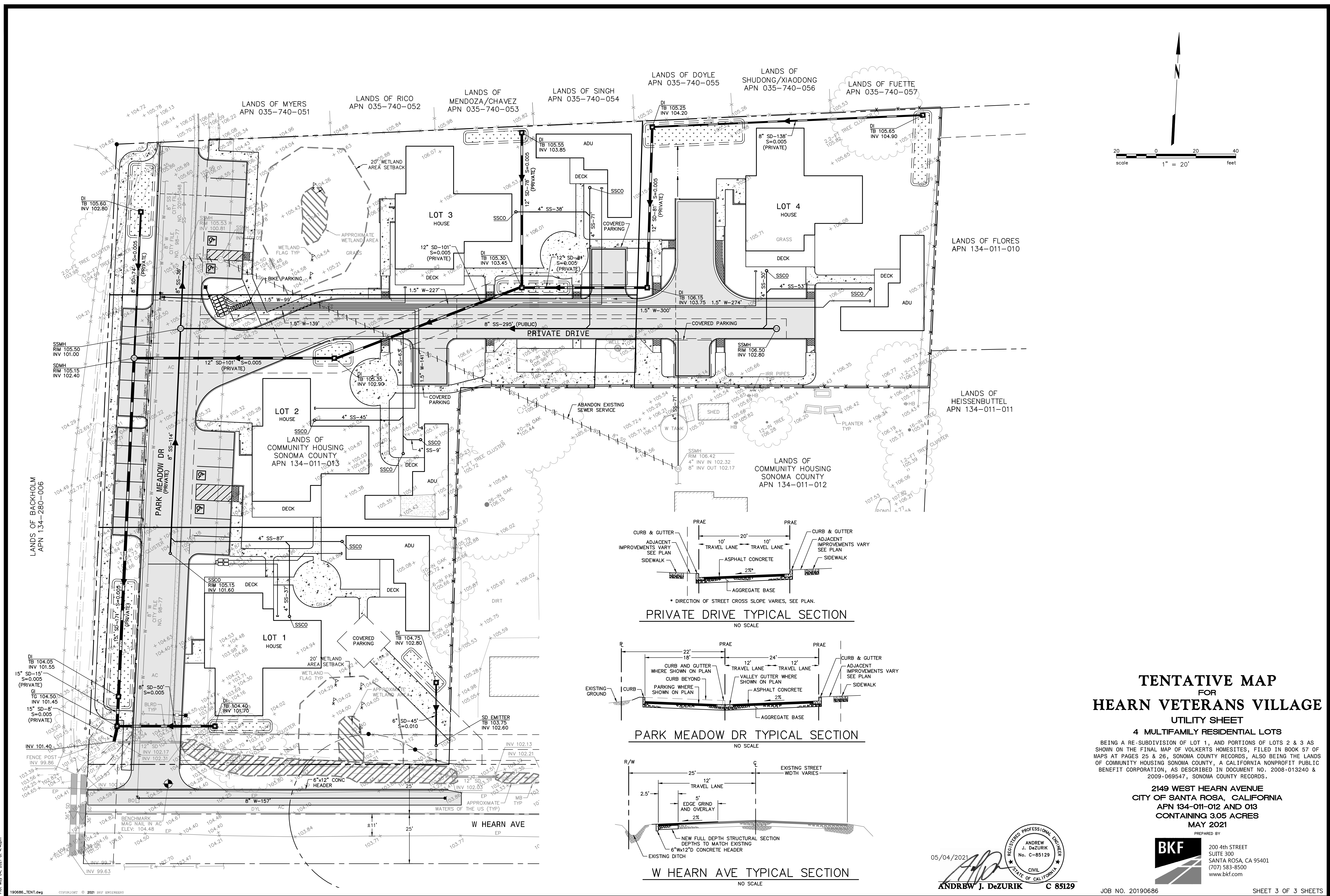
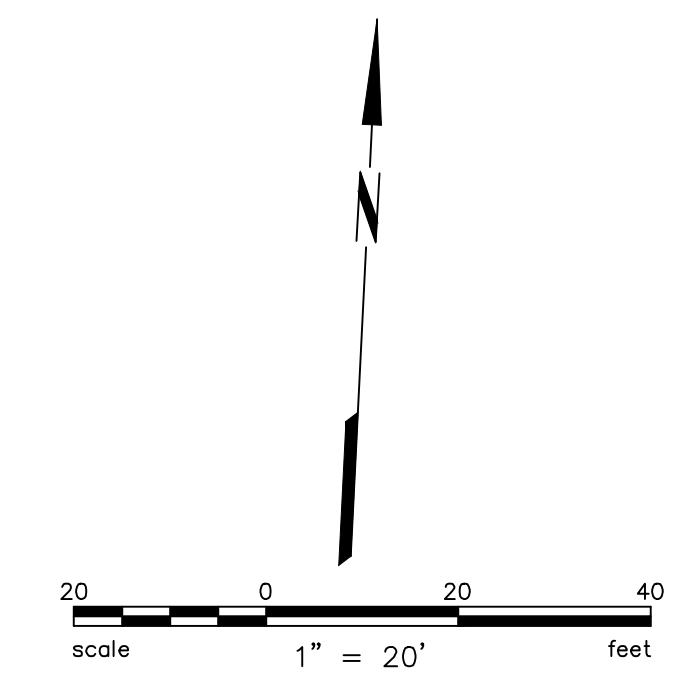

**TENTATIVE MAP
FOR
HEARN VETERANS VILLAGE
UTILITY SHEET**

4 MULTIFAMILY RESIDENTIAL LOTS

BEING A RE-SUBDIVISION OF LOT 1, AND PORTIONS OF LOTS 2 & 3 AS SHOWN ON THE FINAL MAP OF VOLKERT'S HOMESITES, FILED IN BOOK 57 OF MAPS AT PAGES 25 & 26, SONOMA COUNTY RECORDS, ALSO BEING THE LANDS OF COMMUNITY HOUSING SONOMA COUNTY, A CALIFORNIA NONPROFIT PUBLIC BENEFIT CORPORATION, AS DESCRIBED IN DOCUMENT NO. 2008-013240 & 2009-069547, SONOMA COUNTY RECORDS.

**2149 WEST HEARN AVENUE
CITY OF SANTA ROSA, CALIFORNIA
APN 134-011-012 AND 013
CONTAINING 3.05 ACRES
MAY 2021**

PREPARED BY
BKF
200 4th STREET
SUITE 300
SANTA ROSA, CA 95401
(707) 583-8500
www.bkf.com

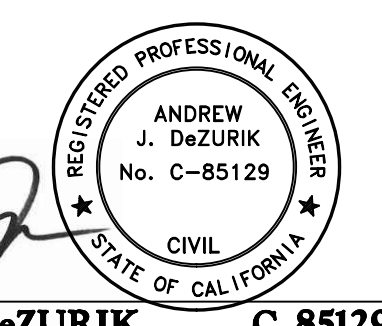

05/04/2021
ANDREW J. DEZURIK C 85129