

# IMPROVEMENT PLANS O'ROURKE TESLA PARKING LOT

SANTA ROSA  
SONOMA COUNTY - CALIFORNIA

AUGUST 2023

City of Santa Rosa  
Planning & Economic  
Development Department  
October 06, 2023  
Received

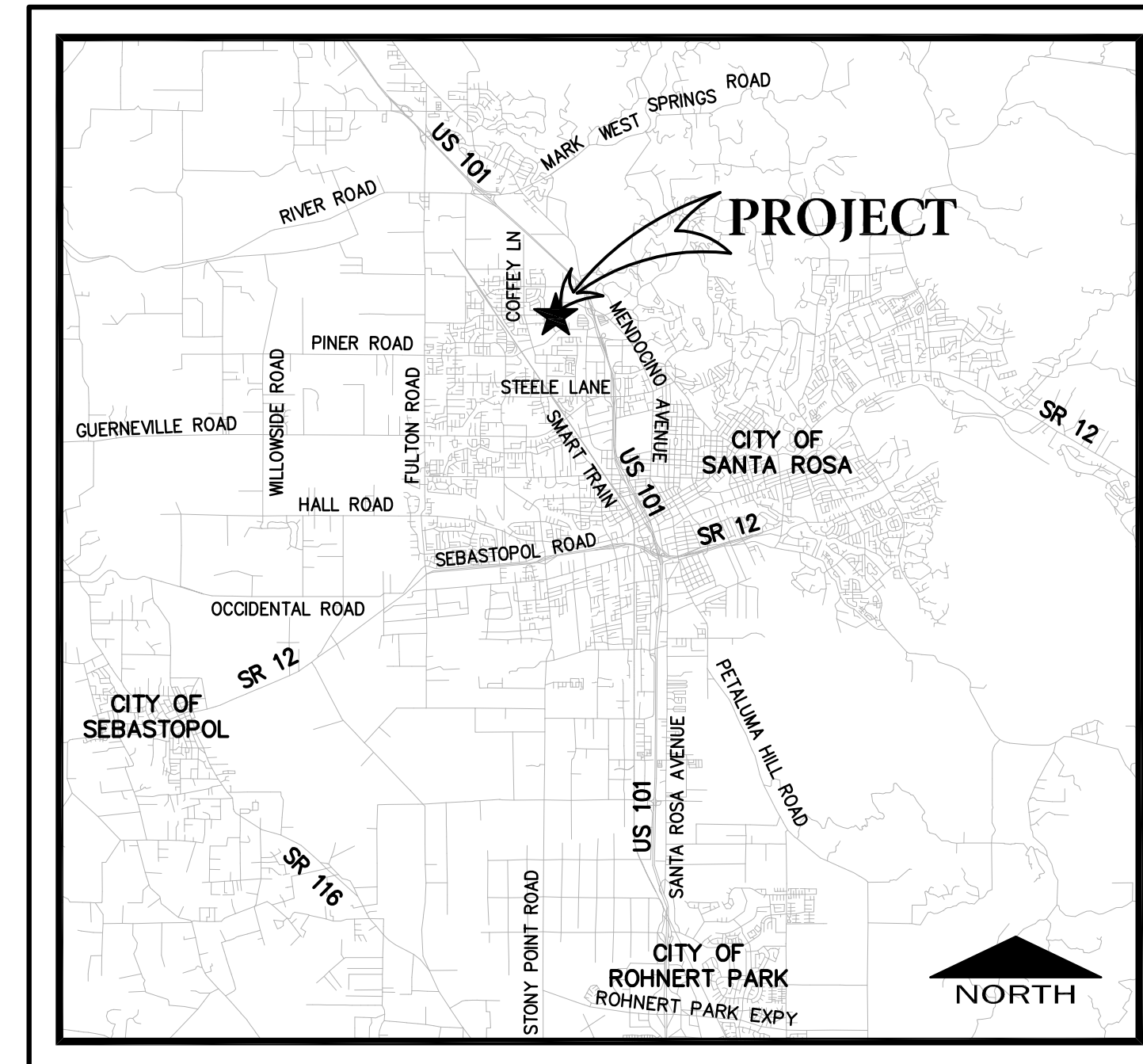

**VICINITY MAP**  
NOT TO SCALE

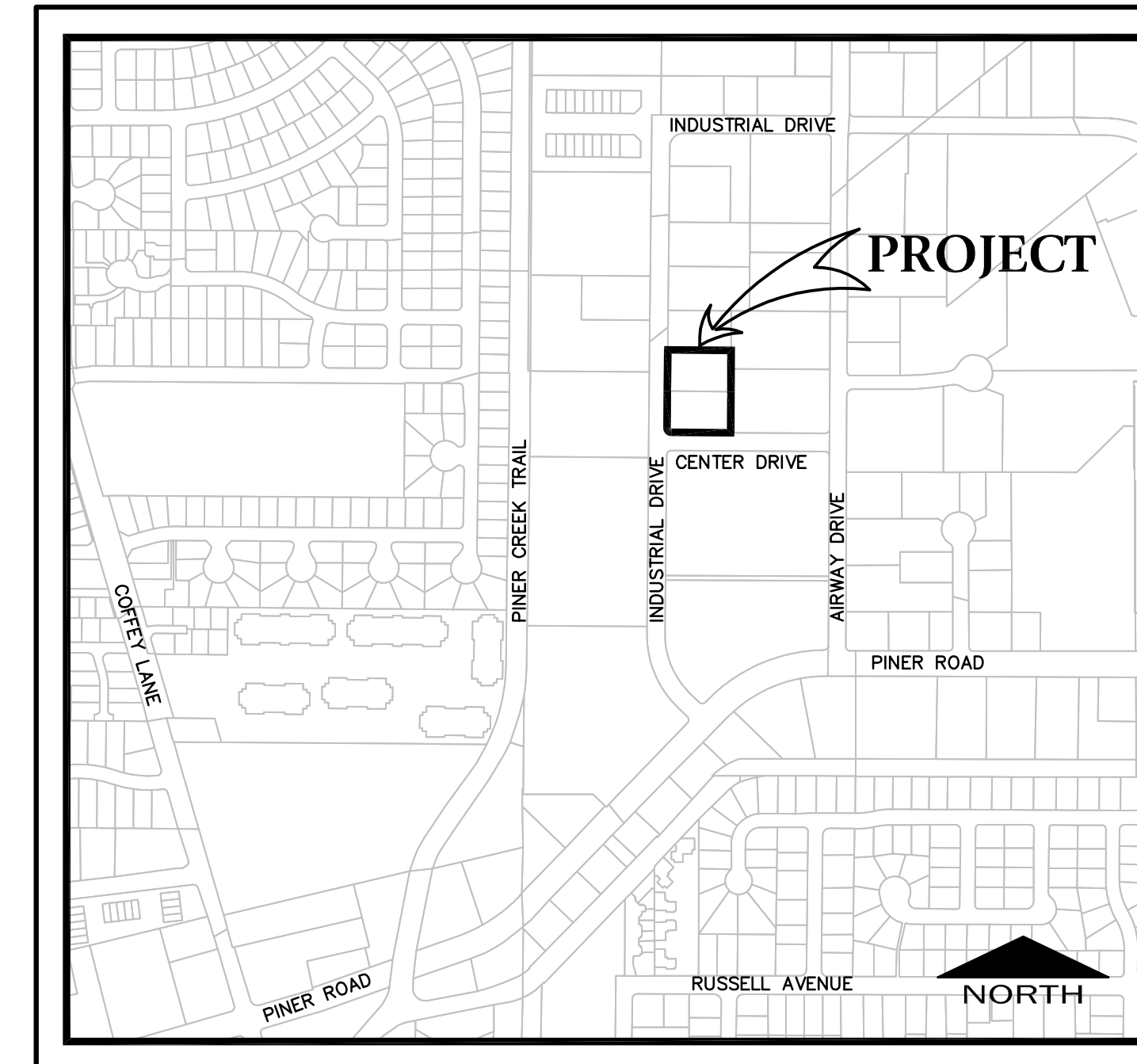

**LOCATION MAP**  
NOT TO SCALE



**CALIFORNIA STATE MAP**  
NOT TO SCALE

**Brelje & Race**  
CONSULTING ENGINEERS  
875 MARKET STREET, SUITE 3300, SANTA ROSA, CA 95403 | 707.576.1322  
www.brelje.com

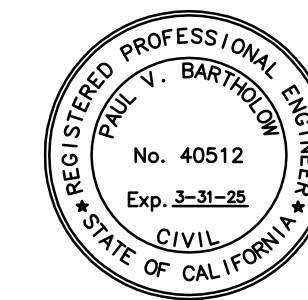

08-102-23 Hilltop\4566.dwg\4566\_02\4566\_02 COVER.dwg TAB: C1-COVER

ABBREVIATIONS

Table of abbreviations with columns for symbol, description, and unit. Includes terms like AB, ASB, AD, ADP, AGS, etc.

LEGEND

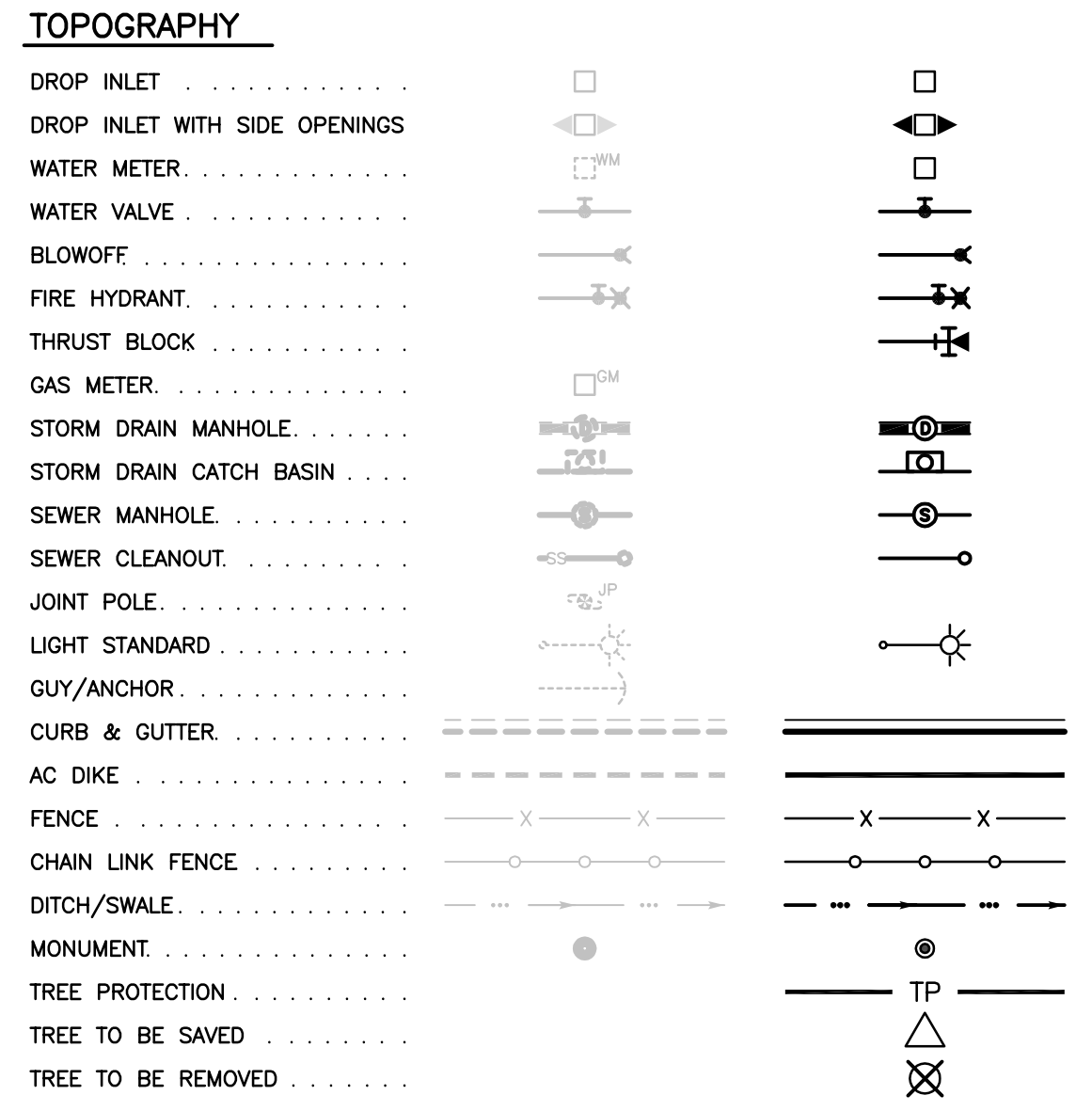
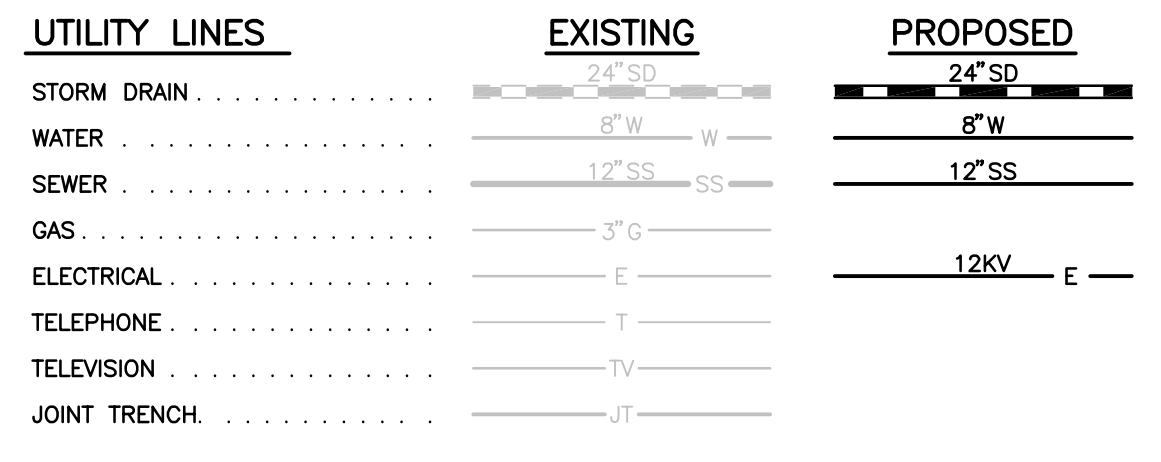
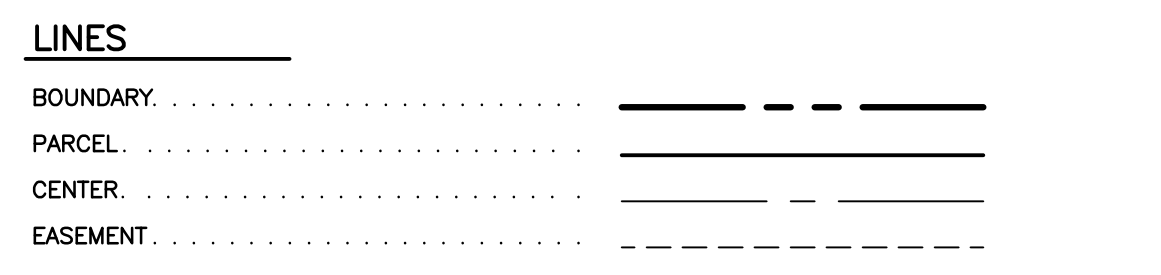

GENERAL UTILITY NOTES

- 1. THE USE OF CONTROLLED DENSITY BACKFILL (CDF) WITH ANY PUBLIC SEWER OR WATER TRENCH IS NOT ALLOWED UNLESS SPECIFICALLY APPROVED BY THE DIRECTOR OF PUBLIC WORKS.
2. THERE SHALL BE NO UNMETERED CONNECTIONS TO THE CITY OF SANTA ROSA WATER SYSTEM...

GENERAL NOTES

- 1. CONTRACTOR SHALL OBTAIN AND PAY FOR ALL CONSTRUCTION PERMITS REQUIRED BY THE CITY OF SANTA ROSA (SUCH AS ENCROACHMENT, GRADING, BUILDING, DEMOLITION ETC.) PRIOR TO COMMENCEMENT OF WORK.
2. AN ENCROACHMENT PERMIT MUST BE OBTAINED FROM THE DEPARTMENT OF PUBLIC WORKS PRIOR TO BEGINNING ANY WORK WITHIN THE PUBLIC RIGHT-OF-WAY...

GRADING NOTES

- 1. NO GRADING, CLEARING OR GRUBBING SHALL BE PERFORMED PRIOR TO ISSUANCE OF A GRADING PERMIT BY THE CITY OF SANTA ROSA.
2. DUST CONTROL SHALL BE PROVIDED BY CONTRACTOR DURING ALL PHASES OF CONSTRUCTION.
3. GRADING SHALL OCCUR ONLY BETWEEN APRIL 15 AND OCTOBER 15 UNLESS OTHERWISE APPROVED BY THE CITY ENGINEER...

EROSION AND SEDIMENT CONTROL NOTES

- 1. EROSION AND SEDIMENT CONTROL SHOWN ON PLANS ASSUMES STREET, CURB, GUTTER AND STORM DRAINS ARE COMPLETED PRIOR TO CONSTRUCTION.
2. EROSION AND SEDIMENT CONTROL MEASURES SHALL BE USED TO ENSURE THAT WATER ENTERING THE STORM DRAIN SYSTEM FROM THE CONSTRUCTION SITE IS OF EQUIVALENT QUALITY AND CHARACTER AS THE WATER ABOVE THE SITE.
3. EROSION AND SEDIMENT CONTROL MEASURES SHALL BE PLACED IN FRONT OF INCOMPLETE STORM DRAIN SYSTEMS...

Breje & Race CONSULTING ENGINEERS
475 Aviation Boulevard, Suite 120
Santa Rosa, CA 95403
t: 707-576-1322
f: 707-576-0469
www.brce.com

PROFESSIONAL ENGINEER
No. 40512
Exp. 2-28-28
STATE OF CALIFORNIA

O'ROURKE TESLA PARKING LOT
3300 & 3304 INDUSTRIAL DRIVE
SANTA ROSA, CALIFORNIA

PRELIMINARY FOR STUDY PURPOSES ONLY DATE AUGUST 2023

Table with columns: NO., DATE, DESCRIPTION. Lists revisions and dates.

Table with columns: PROJECT, DATE, DRAWN BY, CHECKED BY, SYK, PRB.

ABBREVIATIONS, LEGEND & NOTES

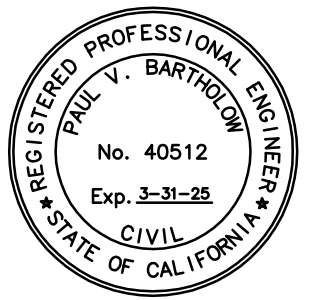

**O'ROURKE TESLA  
PARKING LOT**

3300 & 3304  
INDUSTRIAL DRIVE  
SANTA ROSA, CALIFORNIA

**PRELIMINARY**  
FOR STUDY PURPOSES ONLY  
DATE: AUGUST 2023

REVISIONS		
NO.	DATE	DESCRIPTION

ON A FULL-SCALE DRAWING, LENGTH OF BAR BELOW IS 1-INCH. IF BAR MEASURES LESS THAN 1-INCH, THIS SHEET WAS PLOTTED AT A REDUCED SCALE, WHICH MAY REQUIRE ADJUSTMENT OF SCALE(S) SHOWN ON DRAWING.

PROJECT 4566.02	DATE AUGUST 2023
DRAWN BY SYK	CHECKED BY PRB

**GRADING  
PLAN**

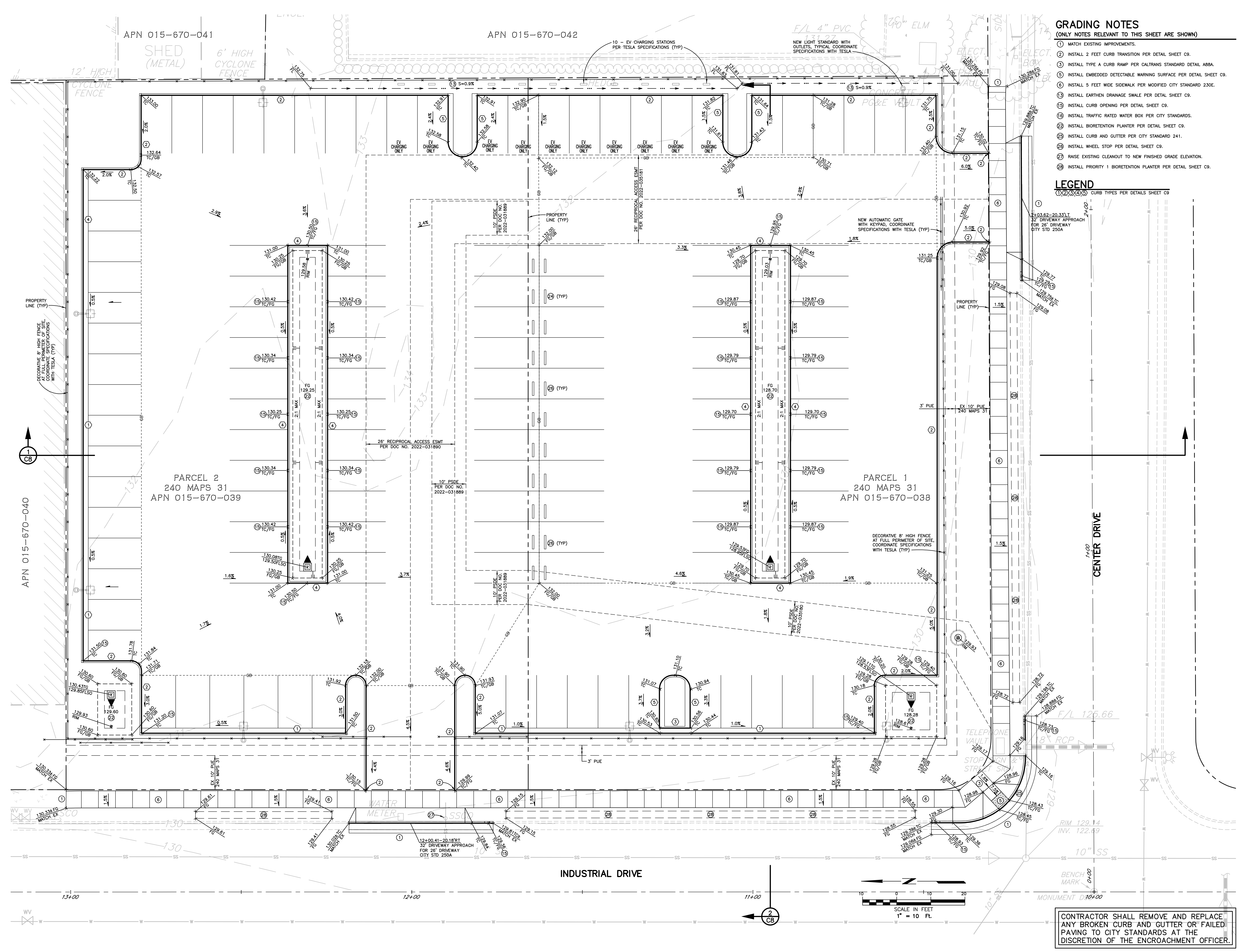

- GRADING NOTES**  
(ONLY NOTES RELEVANT TO THIS SHEET ARE SHOWN)
- MATCH EXISTING IMPROVEMENTS.
  - INSTALL 2 FEET CURB TRANSITION PER DETAIL SHEET C9.
  - INSTALL TYPE A CURB RAMP PER CALTRANS STANDARD DETAIL AB8A.
  - INSTALL EMBEDDED DETECTABLE WARNING SURFACE PER DETAIL SHEET C9.
  - INSTALL 5 FEET WIDE SIDEWALK PER MODIFIED CITY STANDARD 230E.
  - INSTALL EARTHEN DRAINAGE SWALE PER DETAIL SHEET C9.
  - INSTALL CURB OPENING PER DETAIL SHEET C9.
  - INSTALL TRAFFIC RATED WATER BOX PER CITY STANDARDS.
  - INSTALL BIORETENTION PLANTER PER DETAIL SHEET C9.
  - INSTALL CURB AND GUTTER PER CITY STANDARD 241.
  - INSTALL WHEEL STOP PER DETAIL SHEET C9.
  - RAISE EXISTING CLEANOUT TO NEW FINISHED GRADE ELEVATION.
  - INSTALL PRIORITY 1 BIORETENTION PLANTER PER DETAIL SHEET C9.

- LEGEND**  
① ② ③ ④ ⑤ CURB TYPES PER DETAILS SHEET C9

CONTRACTOR SHALL REMOVE AND REPLACE ANY BROKEN CURB AND GUTTER OR FAILED PAVING TO CITY STANDARDS AT THE DISCRETION OF THE ENCROACHMENT OFFICER.

10-06-23 ferrel A:566.dwg 4566 02 4566.02 PLAN.dwg TAB: C3-GRAD

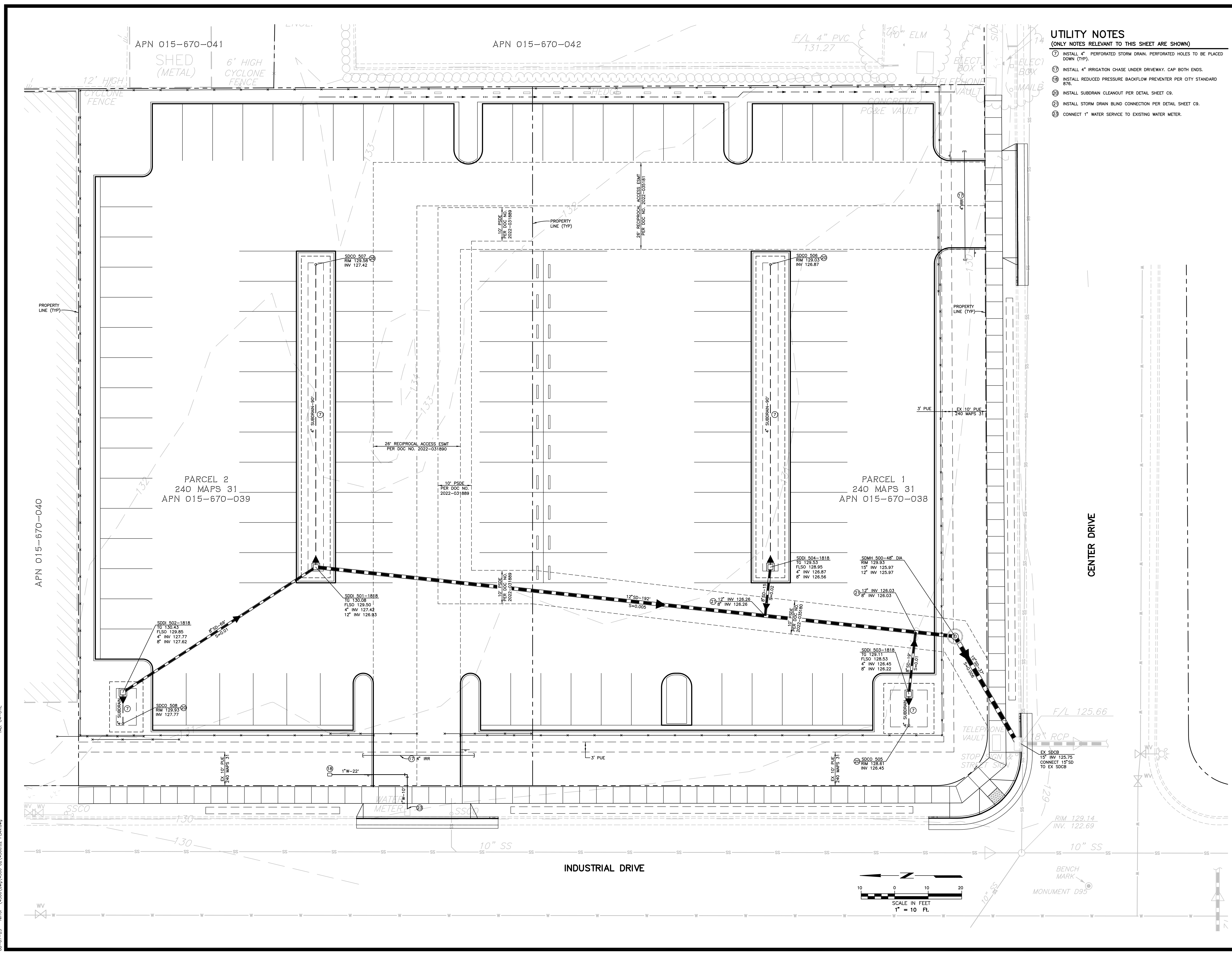

**UTILITY NOTES**  
(ONLY NOTES RELEVANT TO THIS SHEET ARE SHOWN)

- ⑦ INSTALL 4" PERFORATED STORM DRAIN. PERFORATED HOLES TO BE PLACED DOWN (TYP).
- ⑧ INSTALL 4" IRRIGATION CHASE UNDER DRIVEWAY. CAP BOTH ENDS.
- ⑨ INSTALL REDUCED PRESSURE BACKFLOW PREVENTER PER CITY STANDARD 876.
- ⑩ INSTALL SUBDRAIN CLEANOUT PER DETAIL SHEET C9.
- ⑪ INSTALL STORM DRAIN BLIND CONNECTION PER DETAIL SHEET C9.
- ⑫ CONNECT 1" WATER SERVICE TO EXISTING WATER METER.

**Breje & Race**  
CONSULTING ENGINEERS  
475 Aviation Boulevard, Suite 120  
Santa Rosa, CA 95403  
v: 707-576-1322  
f: 707-576-0469  
www.brce.com



**O'ROURKE TESLA  
PARKING LOT**  
3300 & 3304  
INDUSTRIAL DRIVE  
SANTA ROSA, CALIFORNIA

**PRELIMINARY**  
FOR STUDY PURPOSES ONLY  
DATE: AUGUST 2023

REVISIONS		
NO.	DATE	DESCRIPTION

ON A FULL-SCALE DRAWING, LENGTH OF BAR BELOW IS 1-INCH. IF BAR MEASURES LESS THAN 1-INCH, THIS SHEET WAS PLOTTED AT A REDUCED SCALE, WHICH MAY REQUIRE ADJUSTMENT OF SCALE(S) SHOWN ON DRAWING.

PROJECT 4566.02	DATE AUGUST 2023
DRAWN BY SYK	CHECKED BY PRB

**UTILITY  
PLAN**

SHEET NO.  
**C4** OF **9**

08-07-23 ferrel\_A4566.dwg\4566\_02\4566.02\_PLAN.dwg TAB: C4-UTIL

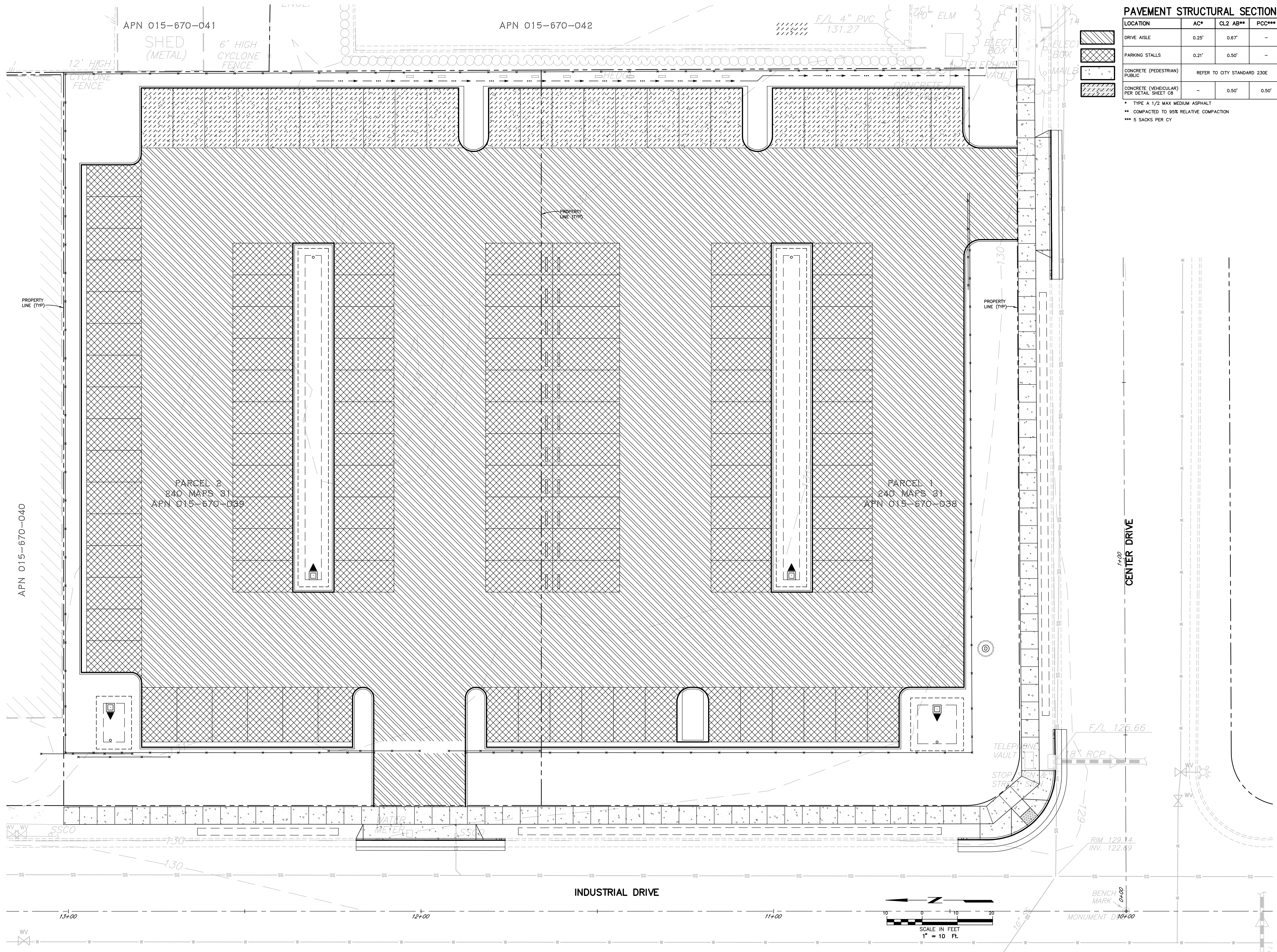

**PAVEMENT STRUCTURAL SECTION**

LOCATION	AC*	CL2 AB**	PCC***
DRIVE AISLE	0.25'	0.67'	-
PARKING STALLS	0.21'	0.50'	-
CONCRETE (PEDESTRIAN) PUBLIC	REFER TO CITY STANDARD 230E		
CONCRETE (VEHICULAR) PER DETAIL SHEET CB	-	0.50'	0.50'

\* TYPE A 1/2 MAX MEDIUM ASPHALT  
 \*\* COMPACTED TO 95% RELATIVE COMPACTION  
 \*\*\* 5 SACKS PER CY

**Breje & Race**  
 CONSULTING ENGINEERS  
 475 Aviation Boulevard, Suite 120  
 Santa Rosa, CA 95403  
 v: 707-576-1322  
 f: 707-576-0469  
 www.brce.com



**O'ROURKE TESLA PARKING LOT**  
 3300 & 3304 INDUSTRIAL DRIVE  
 SANTA ROSA, CALIFORNIA

**PRELIMINARY**  
 FOR STUDY PURPOSES ONLY  
 DATE AUGUST 2023

REVISIONS		
NO.	DATE	DESCRIPTION

ON A FULL-SCALE DRAWING, LENGTH OF BAR BELOW IS 1-INCH. IF BAR MEASURES LESS THAN 1-INCH, THIS SHEET WAS PLOTTED AT A REDUCED SCALE, WHICH MAY REQUIRE ADJUSTMENT OF SCALE(S) SHOWN ON DRAWING.

PROJECT 4566.02	DATE AUGUST 2023
DRAWN BY SYK	CHECKED BY PRB

**PAVEMENT STRUCTURAL SECTION PLAN**

08-07-23 ferrel\_4566.dwg 4566 02\_4566.02 PLAN.dwg TAB: C5-PAVE

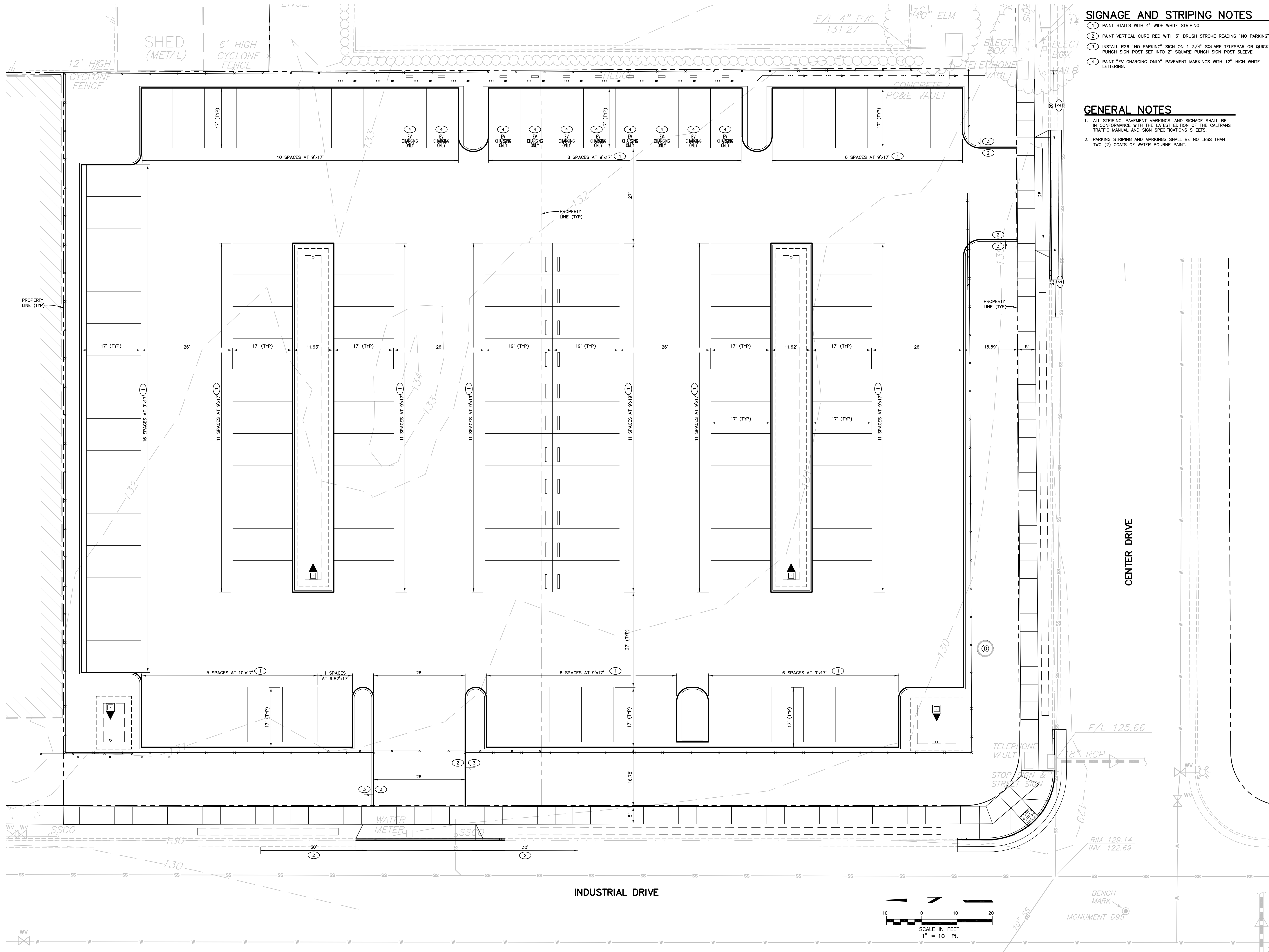

**SIGNAGE AND STRIPING NOTES**

- 1 PAINT STALLS WITH 4" WIDE WHITE STRIPING.
- 2 PAINT VERTICAL CURB RED WITH 3" BRUSH STROKE READING "NO PARKING".
- 3 INSTALL R26 "NO PARKING" SIGN ON 1 3/4" SQUARE TELESPEAR OR QUICK PUNCH SIGN POST SET INTO 2" SQUARE PUNCH SIGN POST SLEEVE.
- 4 PAINT "EV CHARGING ONLY" PAVEMENT MARKINGS WITH 12" HIGH WHITE LETTERING.

**GENERAL NOTES**

- 1. ALL STRIPING, PAVEMENT MARKINGS, AND SIGNAGE SHALL BE IN CONFORMANCE WITH THE LATEST EDITION OF THE CALTRANS TRAFFIC MANUAL AND SIGN SPECIFICATIONS SHEETS.
- 2. PARKING STRIPING AND MARKINGS SHALL BE NO LESS THAN TWO (2) COATS OF WATER BOURNE PAINT.

**Brelje & Race**  
 CONSULTING ENGINEERS  
 475 Aviation Boulevard, Suite 120  
 Santa Rosa, CA 95403  
 v: 707-576-1322  
 f: 707-576-0469  
 www.brce.com



**O'ROURKE TESLA  
 PARKING LOT**  
 3300 & 3304  
 INDUSTRIAL DRIVE  
 SANTA ROSA, CALIFORNIA

**PRELIMINARY**  
 FOR STUDY PURPOSES ONLY  
 DATE AUGUST 2023

REVISIONS		
NO.	DATE	DESCRIPTION

ON A FULL-SCALE DRAWING, LENGTH OF BAR BELOW IS 1-INCH. IF BAR MEASURES LESS THAN 1-INCH, THIS SHEET WAS PLOTTED AT A REDUCED SCALE, WHICH MAY REQUIRE ADJUSTMENT OF SCALE(S) SHOWN ON DRAWING.

PROJECT 4566.02	DATE AUGUST 2023
DRAWN BY SYK	CHECKED BY PRB

**SIGNAGE &  
 STRIPING  
 PLAN**

SHEET NO.  
**C6** OF **9**

08-07-23 ferrol\_4566.dwg 4566 02\_4566.02 PLAN.dwg TAB: C6-SIGNAGE

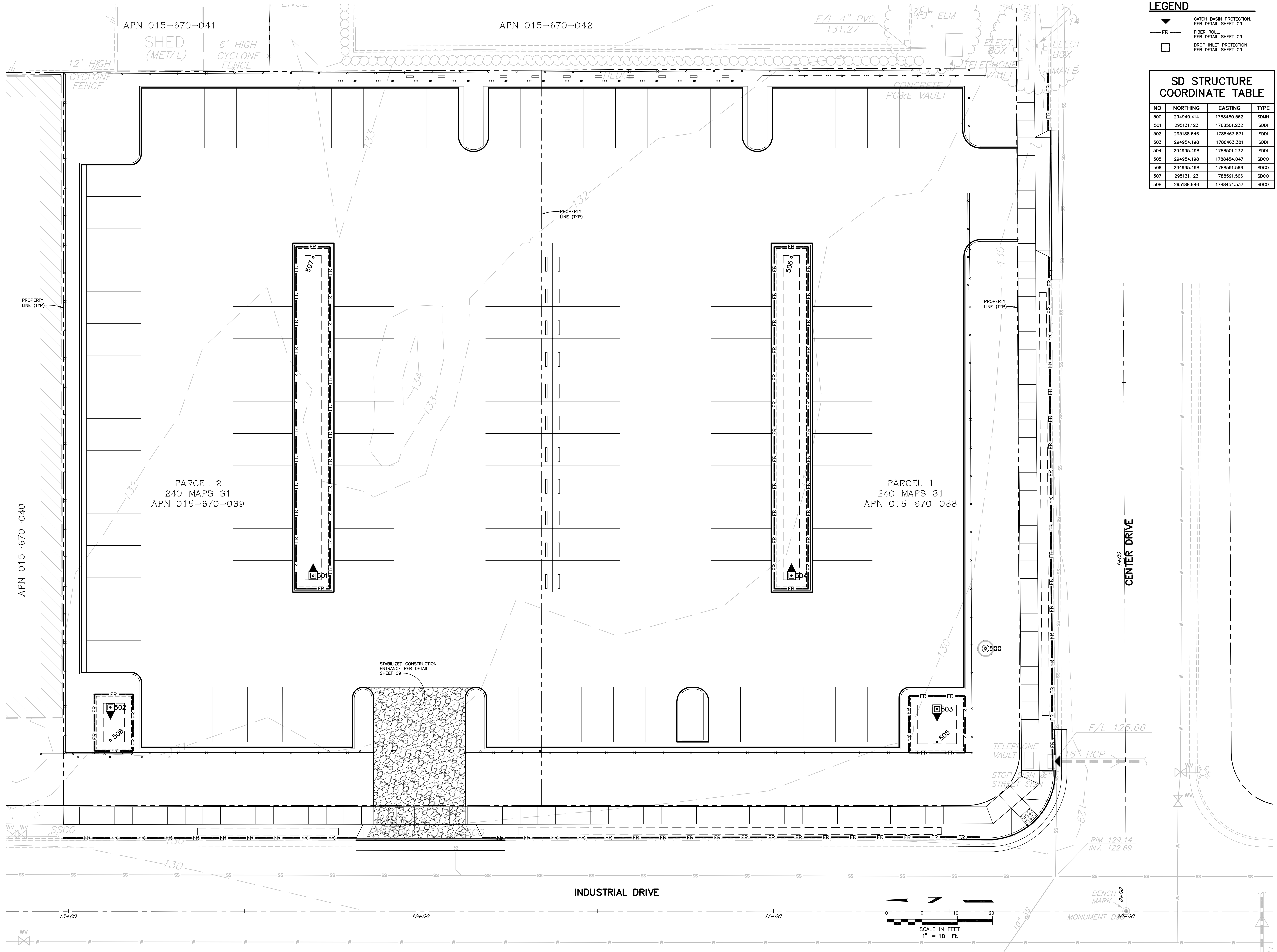

**LEGEND**

- ▼ CATCH BASIN PROTECTION, PER DETAIL SHEET C9
- FR — FIBER ROLL, PER DETAIL SHEET C9
- DROP INLET PROTECTION, PER DETAIL SHEET C9

**SD STRUCTURE COORDINATE TABLE**

NO	NORTHING	EASTING	TYPE
500	294940.414	1788480.562	SDMH
501	295131.123	1788501.232	SDDI
502	295188.646	1788463.871	SDDI
503	294954.198	1788463.381	SDDI
504	294954.198	1788501.232	SDDI
505	294954.198	1788454.047	SDCO
506	294995.498	1788591.566	SDCO
507	295131.123	1788591.566	SDCO
508	295188.646	1788454.537	SDCO

**Brelje & Race**  
CONSULTING ENGINEERS  
475 Aviation Boulevard, Suite 120  
Santa Rosa, CA 95403  
v: 707-576-1322  
f: 707-576-0469  
www.brce.com

**O'ROURKE TESLA PARKING LOT**  
3300 & 3304 INDUSTRIAL DRIVE  
SANTA ROSA, CALIFORNIA

**PRELIMINARY**  
FOR STUDY PURPOSES ONLY  
DATE AUGUST 2023

**REVISIONS**

NO.	DATE	DESCRIPTION

ON A FULL-SCALE DRAWING, LENGTH OF BAR BELOW IS 1-INCH. IF BAR MEASURES LESS THAN 1-INCH, THIS SHEET WAS PLOTTED AT A REDUCED SCALE, WHICH MAY REQUIRE ADJUSTMENT OF SCALE(S) SHOWN ON DRAWING.

PROJECT 4566.02	DATE AUGUST 2023
DRAWN BY SYK	CHECKED BY PRB

**LAYOUT & EROSION CONTROL PLAN**

08-07-23 ferrel\_A4566.dwg 4566 02\_A4566.02\_PLAN.dwg TAB: C7-EC

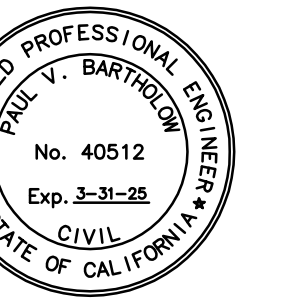

**O'ROURKE TESLA  
 PARKING LOT**  
 3300 & 3304  
 INDUSTRIAL DRIVE  
 SANTA ROSA, CALIFORNIA

**PRELIMINARY**  
 FOR STUDY PURPOSES ONLY  
 DATE AUGUST 2023

REVISIONS		
NO.	DATE	DESCRIPTION

ON A FULL-SCALE DRAWING, LENGTH OF BAR BELOW IS 1-INCH. IF BAR MEASURES LESS THAN 1-INCH, THIS SHEET WAS PLOTTED AT A REDUCED SCALE, WHICH MAY REQUIRE ADJUSTMENT OF SCALE(S) SHOWN ON DRAWING.

PROJECT 4566.02	DATE AUGUST 2023
DRAWN BY SYK	CHECKED BY PRB

**SITE  
 SECTIONS**

SHEET NO.  
**C8 OF 9**

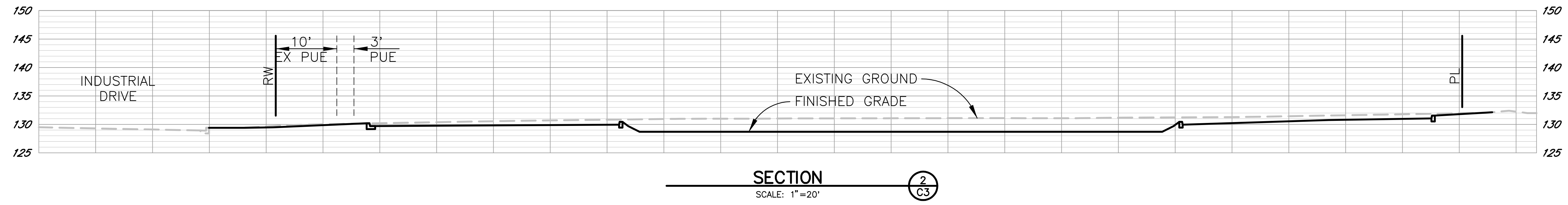
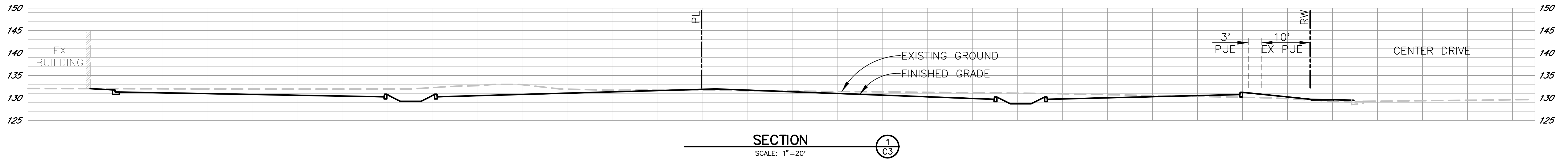

08-07-23 Hilltoph V:\4566.dwg\4566\_02\4566.02\_SECTION.dwg



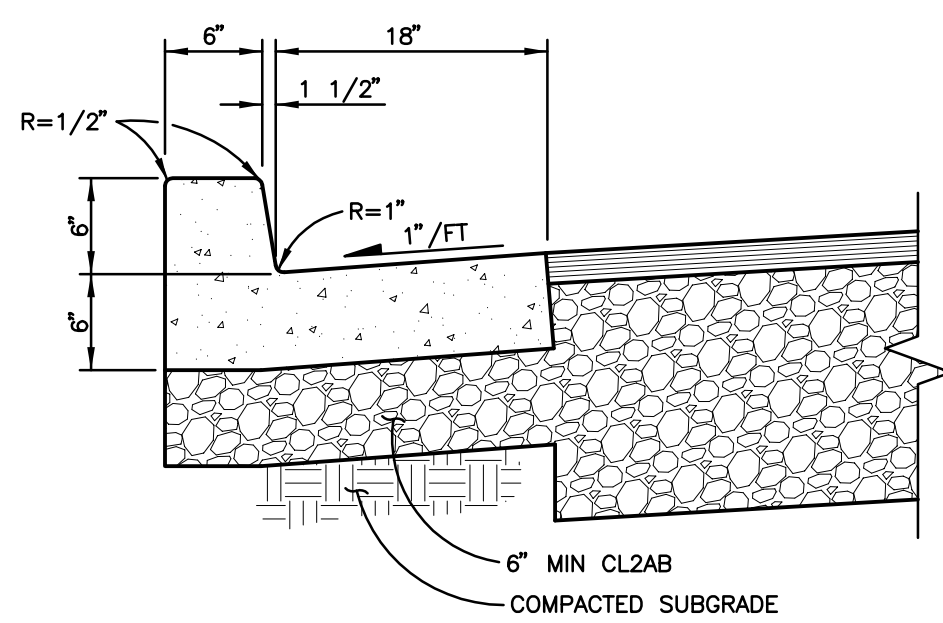

**TYPE 1**  
**CURB AND GUTTER**  
NOT TO SCALE

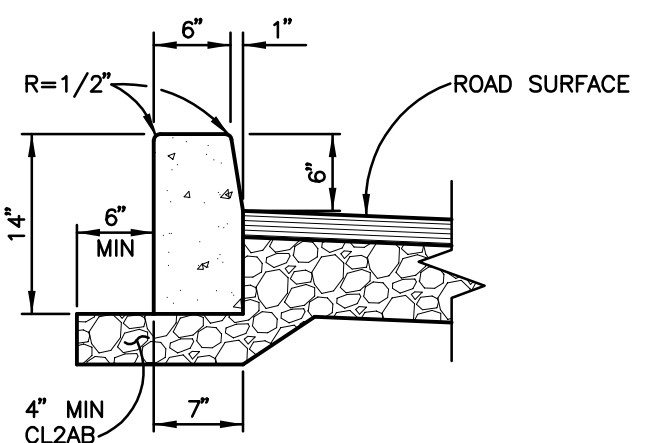

**TYPE 2**  
**STANDARD VERTICAL CURB**  
NOT TO SCALE

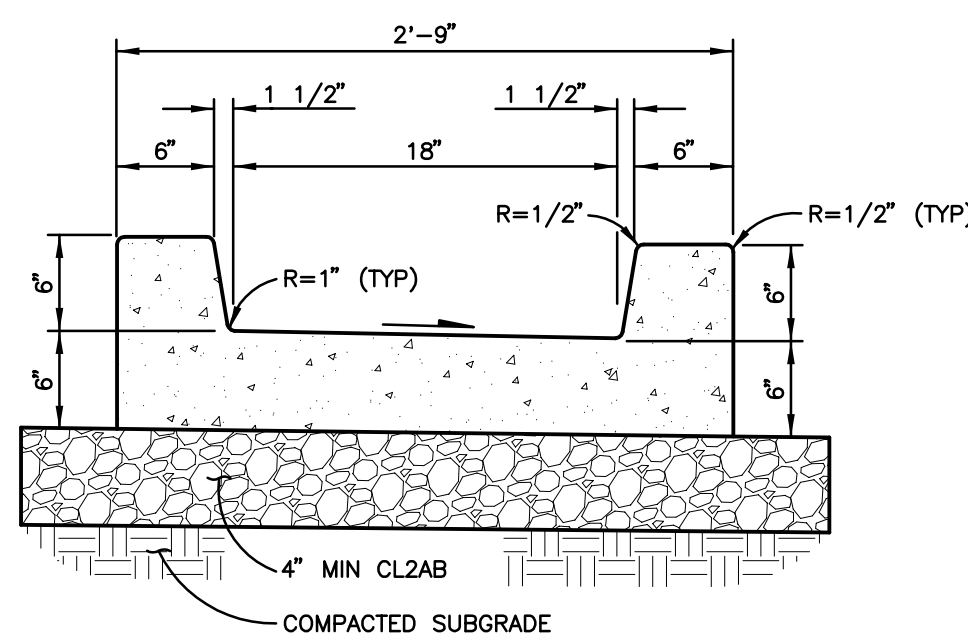

**TYPE 3**  
**CURB AND GUTTER**  
NOT TO SCALE

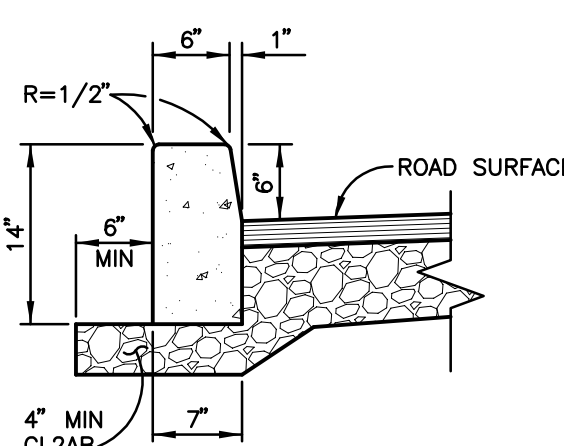

**TYPE 4**  
**STANDARD VERTICAL CURB**  
NOT TO SCALE

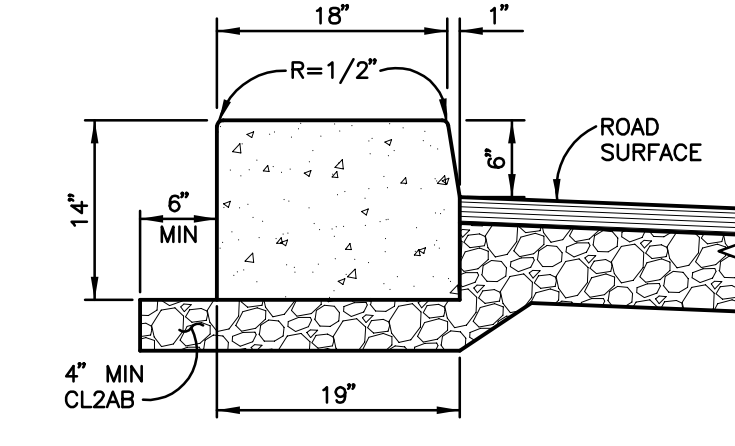

**TYPE 5**  
**STANDARD VERTICAL CURB**  
NOT TO SCALE

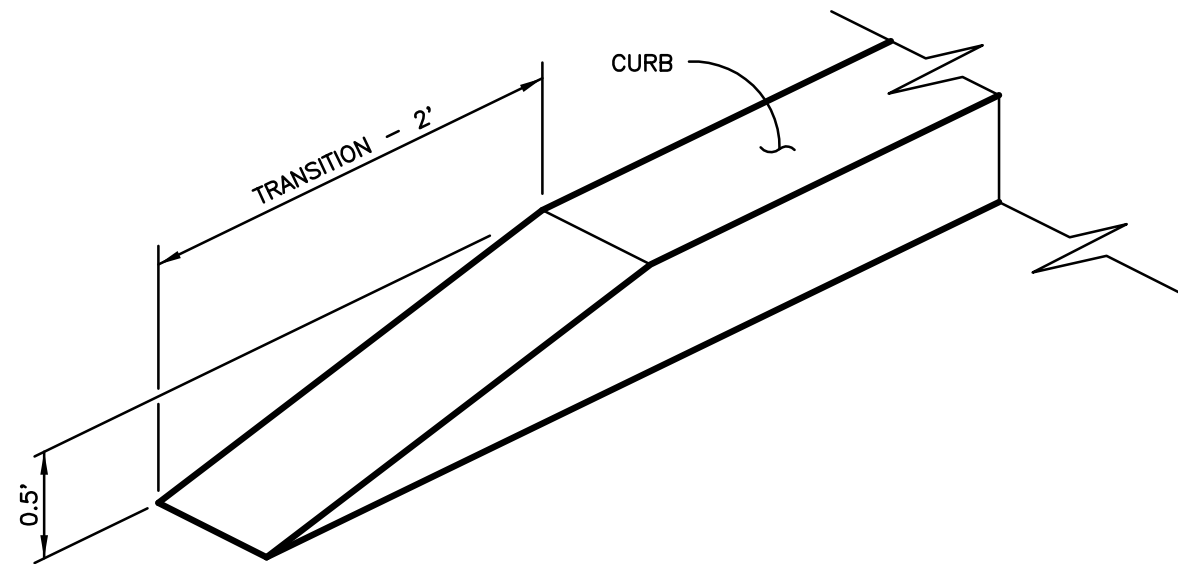

**CURB TRANSITION**  
NOT TO SCALE

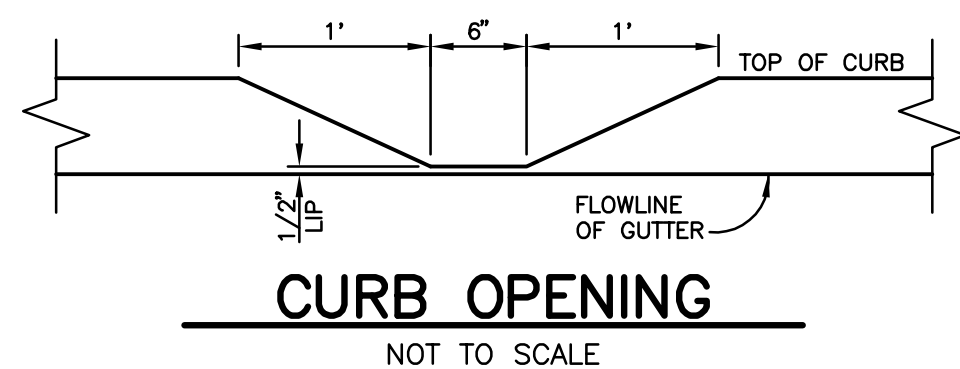

**CURB OPENING**  
NOT TO SCALE

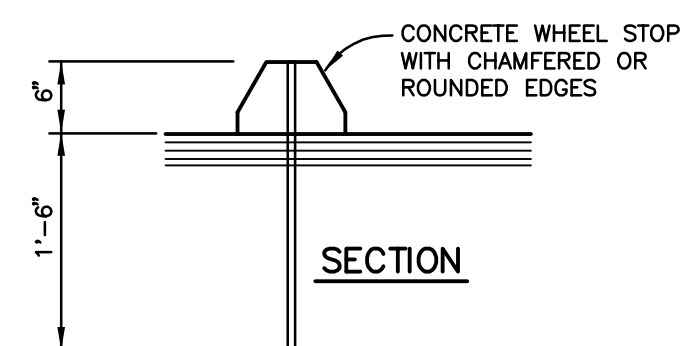

**WHEEL STOP**  
NOT TO SCALE

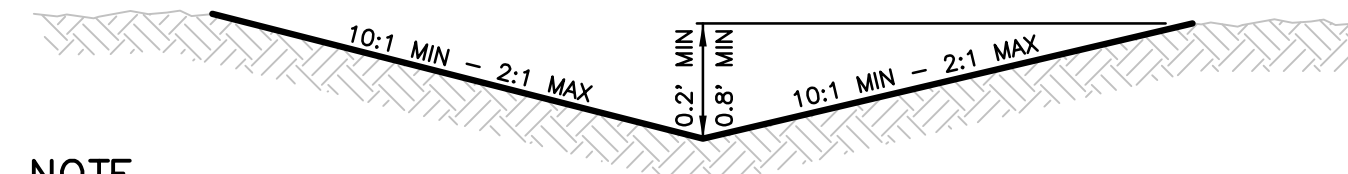

**EARTHEN DRAINAGE SWALE**  
NOT TO SCALE

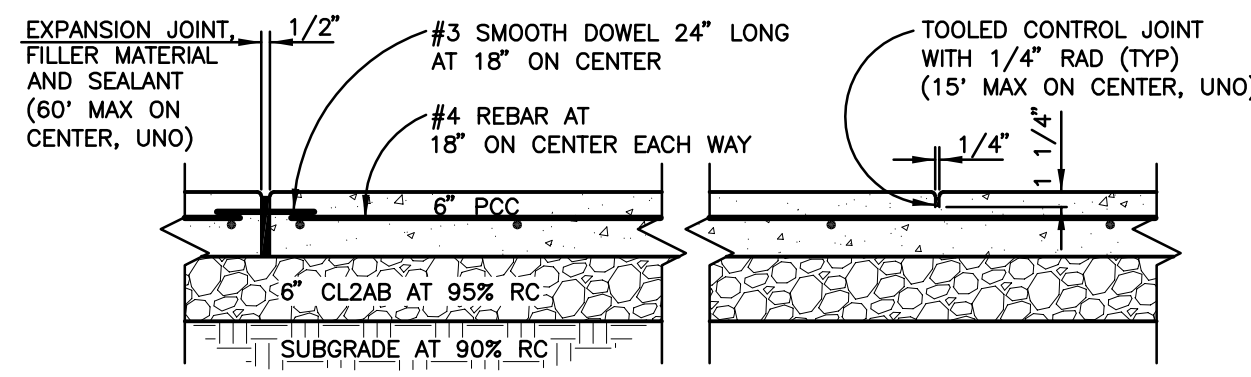

**PCC WALK SECTION AND JOINT (VEHICULAR)**  
NOT TO SCALE

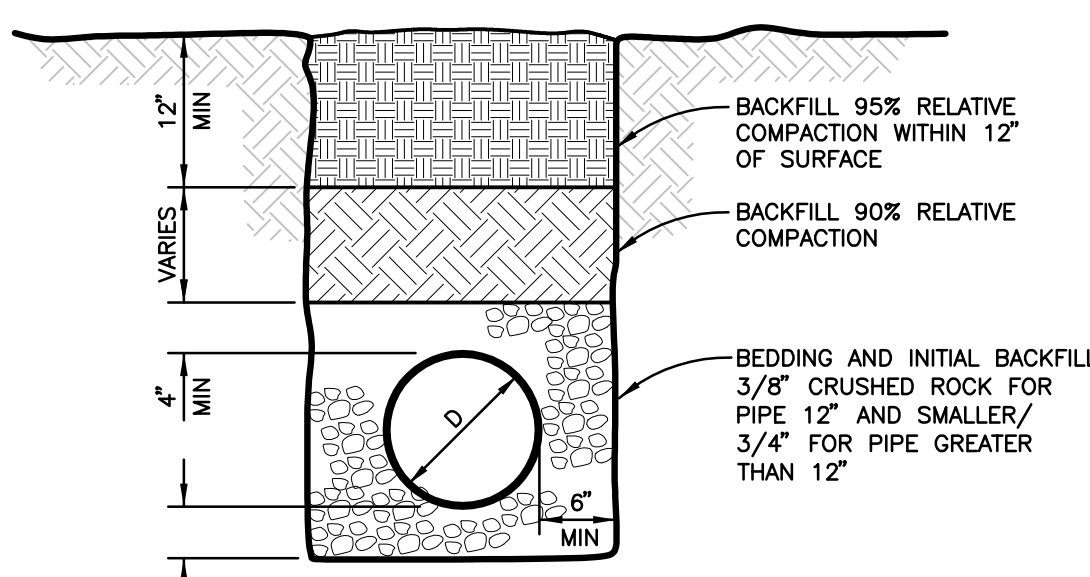

**STANDARD TRENCH**  
NOT TO SCALE

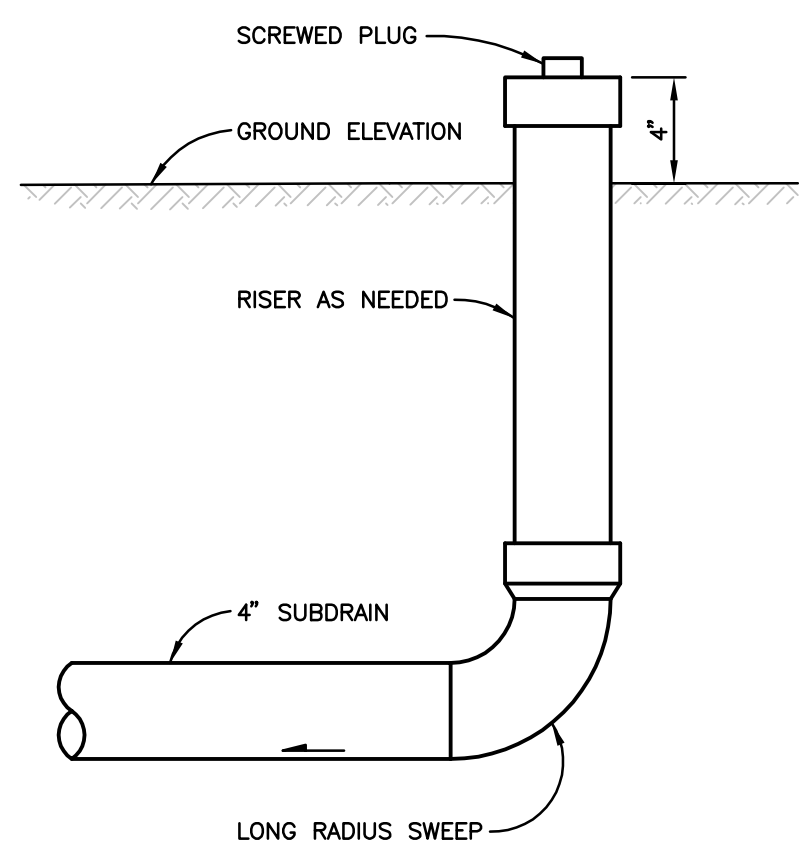

**SUBDRAIN CLEANOUT**  
NOT TO SCALE

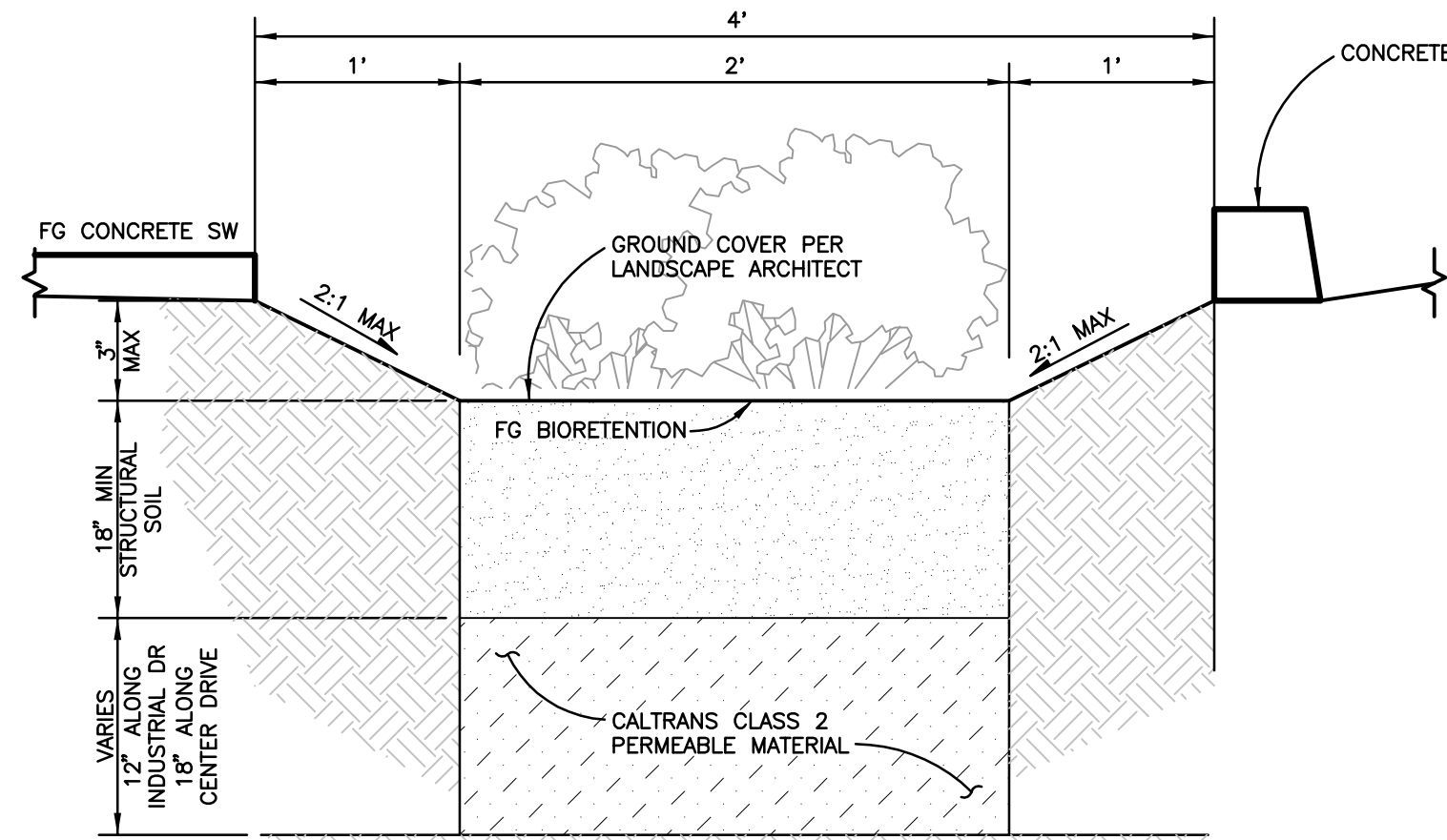

**BIORETENTION PLANTER - PRIORITY 1**  
NOT TO SCALE

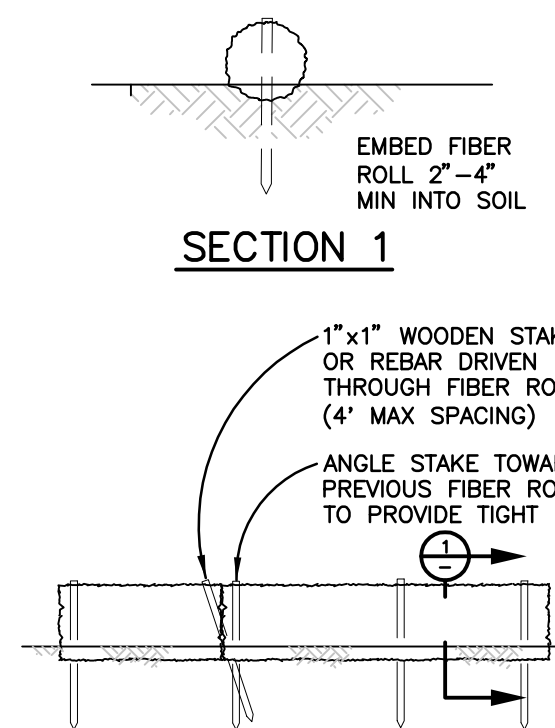

**FIBER ROLL**  
NOT TO SCALE

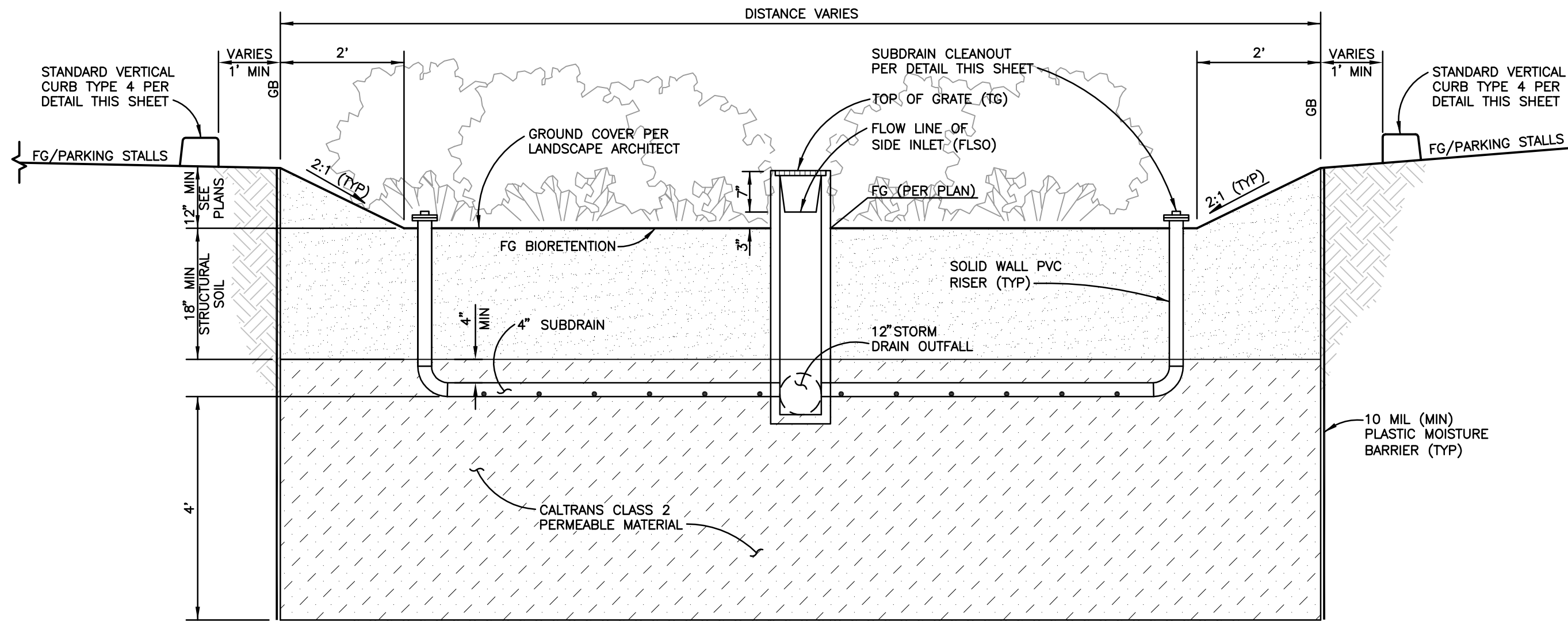

**BIORETENTION PLANTER**  
NOT TO SCALE

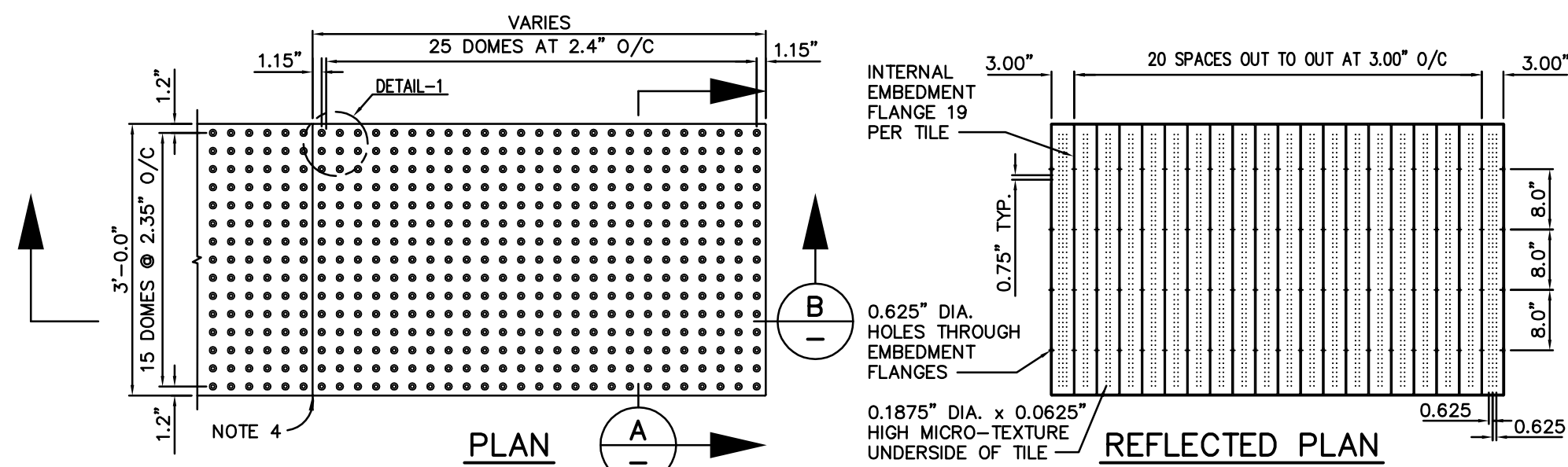

**EMBEDDED DETECTABLE WARNING SURFACE**  
NOT TO SCALE

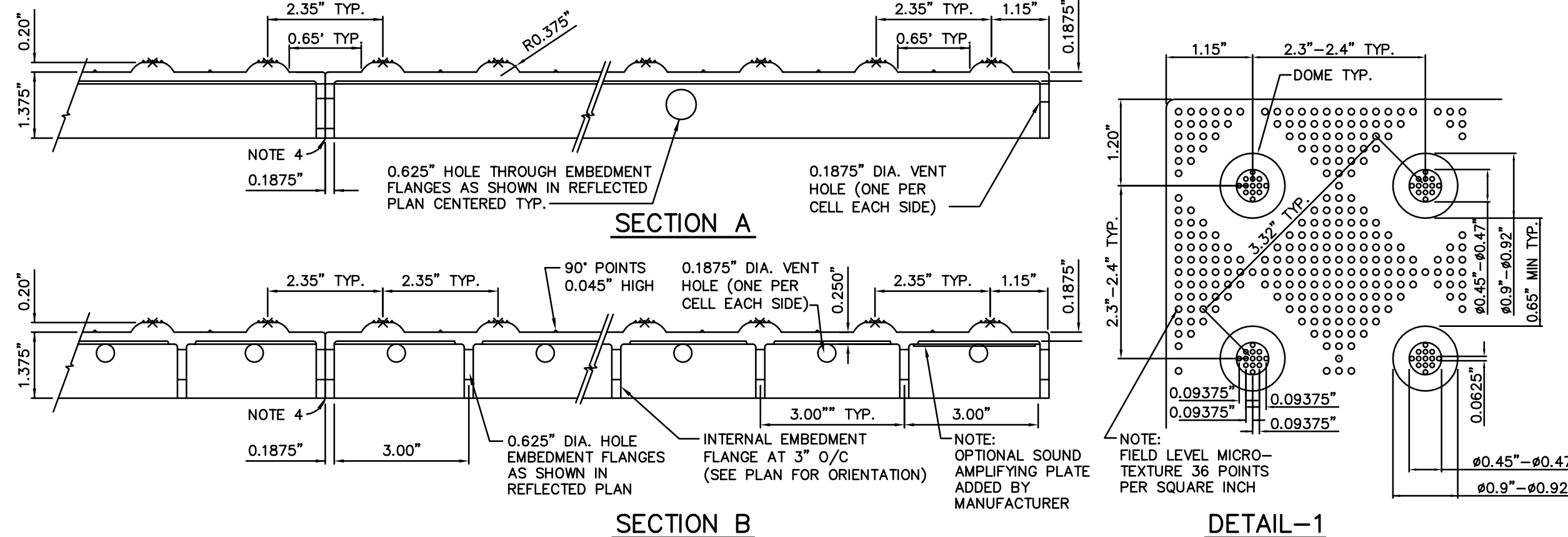

**NOTES**  
1. DETAIL FOR 36"x60" SHOWN. DETAIL FOR OTHER SIZE TILES SIMILAR.  
2. TILE COLOR TO BE YELLOW.  
3. TILES TO BE PLACED FULL WIDTH OF RAMP, EXCLUDING FLARES, AND A MINIMUM LENGTH OF 3FT IN THE DIRECTION OF TRAVEL.  
4. WHEN PLACING SEPARATE TILES TOGETHER, ADJACENT TILES SHALL MAINTAIN TRUNCATED DOMES CENTER-TO-CENTER AND BASE-TO-BASE SPACING BETWEEN THE SQUARE GRIDS, AS WELL AS LINEAL ALIGNMENT.

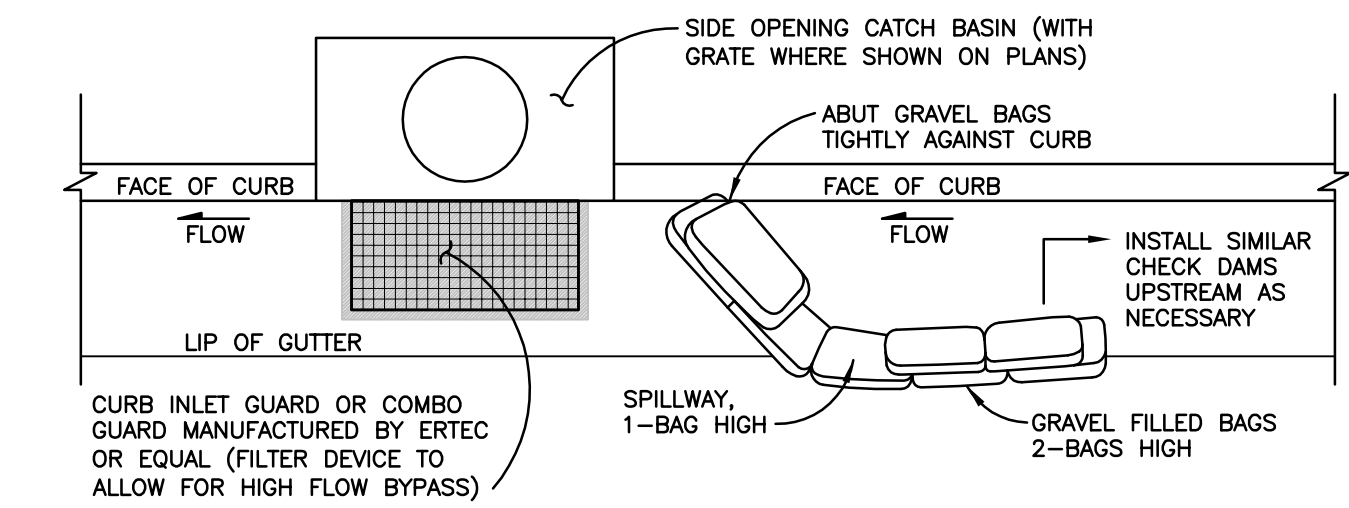

**CATCH BASIN PROTECTION - ON GRADE**  
NOT TO SCALE

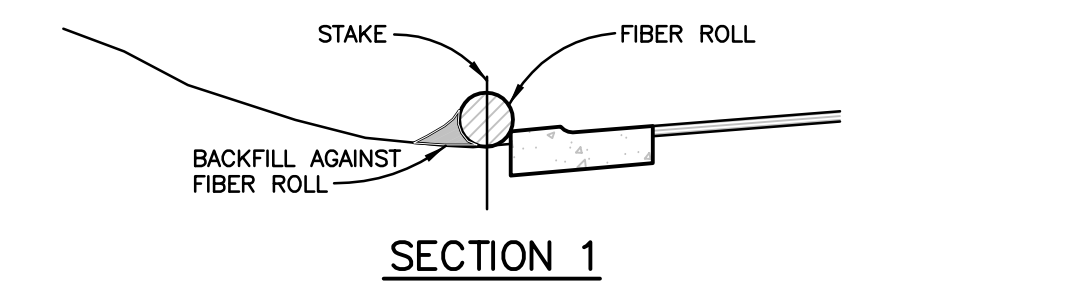

**FIBER ROLL AT DRIVEWAY CUT**  
(TYPICAL ALL DRIVEWAYS)  
NOT TO SCALE

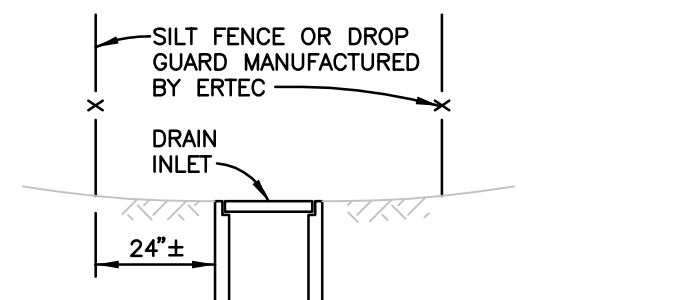

**DROP INLET PROTECTION-TYPE 1**  
NOT TO SCALE

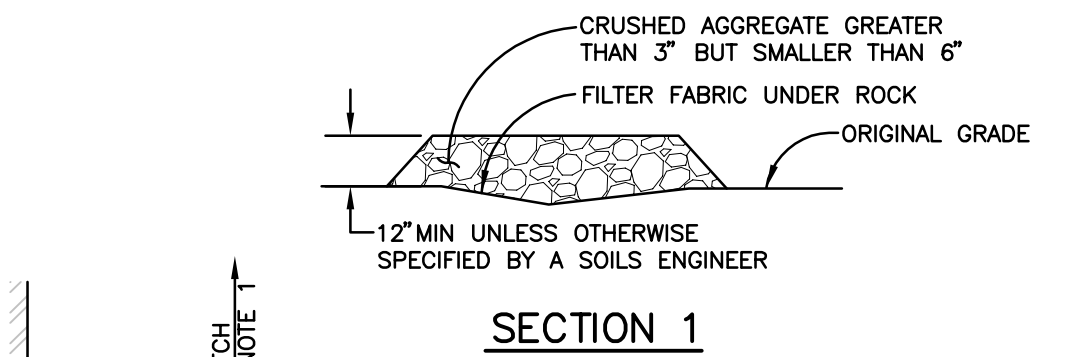

**NOTES**  
1. CONSTRUCT SEDIMENT BARRIER AND CHANNELIZE RUNOFF TO SEDIMENT TRAPPING DEVICE.  
2. THE ENTRANCE SHALL BE MAINTAINED IN A CONDITION THAT WILL PREVENT TRACKING OR FLOWING OF SEDIMENT ONTO PUBLIC RIGHTS-OF-WAY. THIS MAY REQUIRE TOP DRESSING, REPAIR AND/OR CLEANOUT OF ANY MEASURES USED TO TRAP SEDIMENT.  
3. WHEN NECESSARY, WHEELS SHALL BE CLEANED PRIOR TO ENTRANCE ONTO PUBLIC RIGHT-OF-WAY.  
4. WHEN WASHING IS REQUIRED, IT SHALL BE DONE ON AN AREA STABILIZED WITH CRUSHED STONE AND/OR CORRUGATED STEEL PANELS THAT DRAINS INTO AN APPROVED SEDIMENT TRAP OF SEDIMENT BASIN.

**STABILIZED CONSTRUCTION ENTRANCE**  
NOT TO SCALE

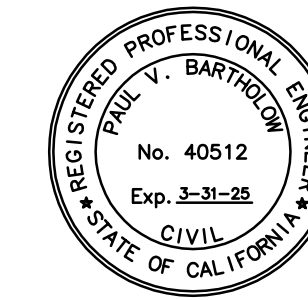

REVISIONS		
NO.	DATE	DESCRIPTION

ON A FULL-SCALE DRAWING, LENGTH OF BAR BELOW IS 1-INCH. IF BAR MEASURES LESS THAN 1-INCH, THIS SHEET WAS PLOTTED AT A REDUCED SCALE, WHICH MAY REQUIRE ADJUSTMENT OF SCALE(S) SHOWN ON DRAWING.

PROJECT	DATE
4566.02	AUGUST 2023
DRAWN BY	CHECKED BY
SYK	PRB