

T:\2018 PROJECTS\18066_Village\Adobe-Design\Tentative Map\Exhibits\18066-Roseland Spec Spine Exhibit_20181206.dwg, Tim Gleason, 12/6/2018 4:42:28 PM

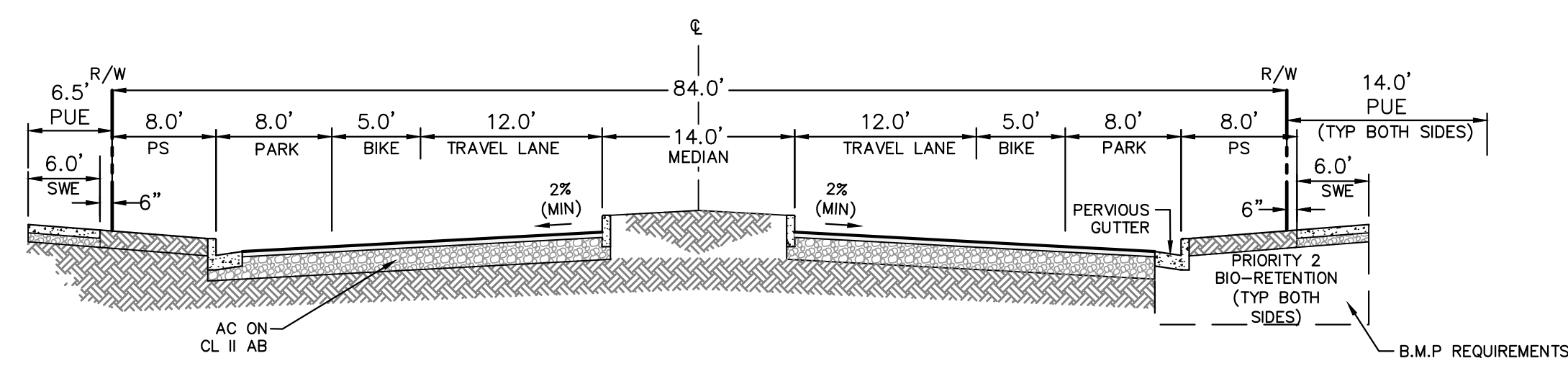

MAJOR STREET SECTION
3 LANE ROAD WITH MEDIAN (PUBLIC)
PER CITY OF SANTA ROSA STD 200J - MAJOR STREET

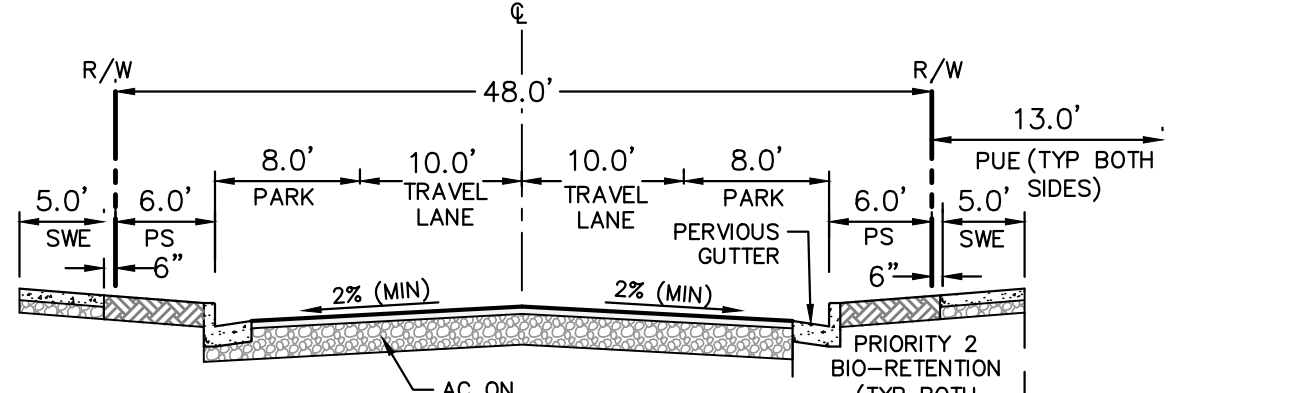

MINOR STREET SECTION
Street A (PUBLIC)
PER CITY OF SANTA ROSA STD 200E - MINOR STREET

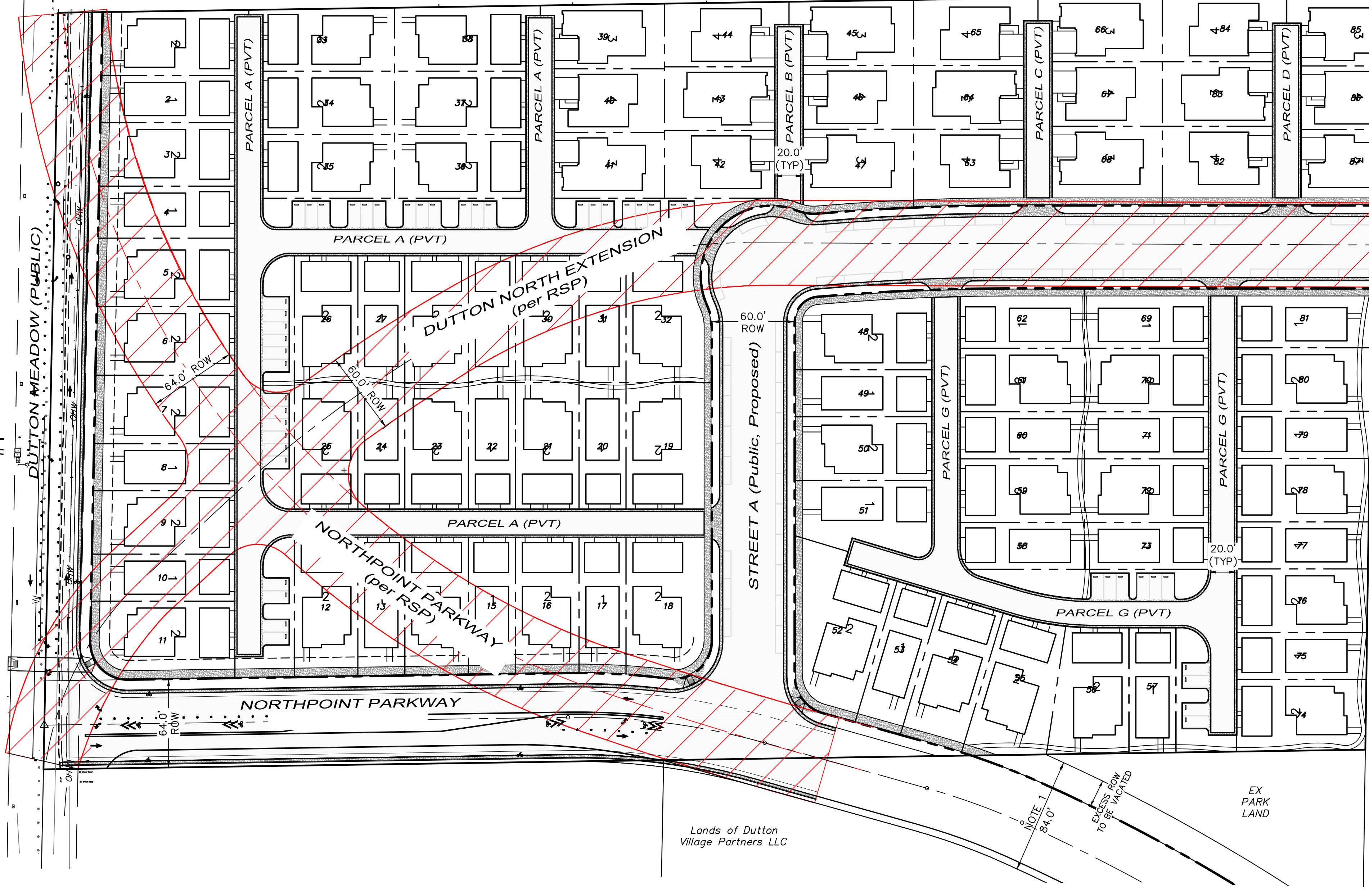
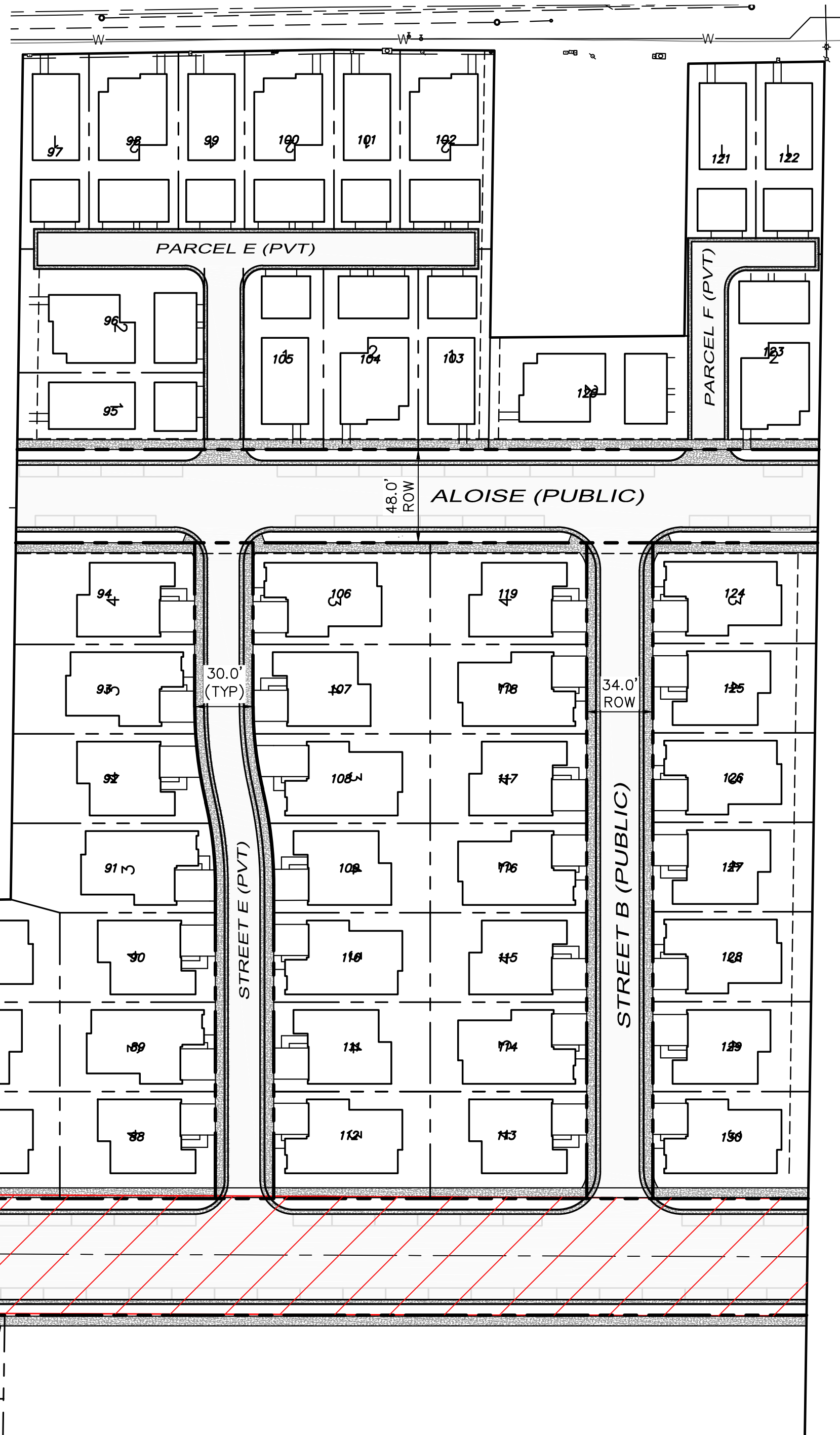

NOTES:

- ALL R.O.W.'S PER THE ROSELAND SPECIFIC PLAN
- 26± UNITS WOULD BE AFFECTED BY R.S.P.

 DUTTON MEADOWS & NORTHPOINT PARKWAY PER R.S.P.

KEY NOTES:

1. EXISTING NORTHPOINT PARKWAY RIGHT-OF-WAY (DEDICATED BY CATALINA TOWNHOMES)

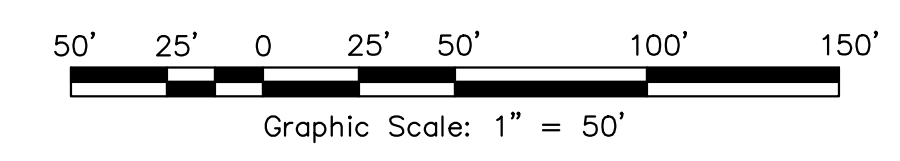

Lands of Dutton Village Partners LLC

NOTE 1
84'-0"
EXCESS ROW TO BE VACATED

EX PARK LAND

Dutton Meadows Subdivision
Northpoint Parkway Interchange Exhibit

HEARN AVENUE LLC & DM ASSOCIATES LLC
2650, 2666, 2684 Dutton Meadow & 1112, 1200 Hearn Ave, Santa Rosa, CA
APN 043-071-007, 022, 023

December 06, 2018

adobe associates, inc.
civil engineering | land surveying | wastewater

1220 N. Dutton Ave., Santa Rosa, CA 95401
P: (707) 541-2300 F: (707) 541-2301
Website: www.adobecinc.com

*A Service You Can Count On!