

ROSELAND SCHOOL

LOT 15
PG 125.59

LOT 16

LOT 17

PRIVATE ROAD F

EG/FG 125.5 CONFORM

5.0'

5.5' SWE

PVT. 8" SD

125.21 FG

16.0'

89'

124.2 FG

8" SD

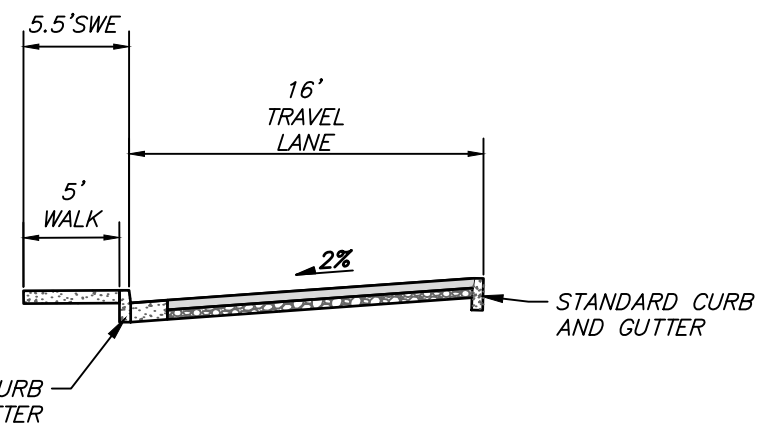
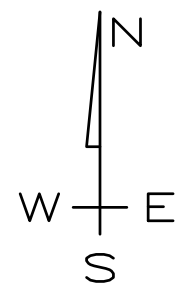

PRIVATE ROAD F ACCESS

SCALE 1"=10'

TYPICAL SECTION
PRIVATE ROAD F

MUNSELLE CIVIL ENGINEERING
 ♦ CIVIL ENGINEERING ♦ SURVEYING ♦
 ♦ PLANNING ♦ CONST. MANAGEMENT ♦
 513 CENTER STREET
 HEALDSBURG, CA 95448
 (707) 395-0968



MUNSELLE
 CIVIL ENGINEERING
 CIVIL ENGINEERING LAND PLANNING

SCHOOL ACCESS EXHIBIT
SHELLINGER BURBANK
 125-331-003, 125-361-006, 125-361-007, 125-361-003
 1400, 1690, 1720, 1780 BURBANK AVE.
 SANTA ROSA, CA

DATE:
12-24-19

JOB NO.
169-17

SHEET 1 OF 1

D:\DROPOX\MCE_JOBS\2017\169-17 WORDEN SUBDIVISION-SHELLINGER\DWGS\169-17 TM.DWG 12/24/2019 9:26 AM TY