

NOT FOR CONSTRUCTION



**LEGEND**

<span style="display:inline-block; width:15px; height:10px; background-color:orange;"></span>	NEW IMPERVIOUS AREAS
<span style="display:inline-block; width:15px; height:10px; background-color:blue;"></span>	REPAVED IMPERVIOUS AREAS
<span style="display:inline-block; width:15px; height:10px; background-color:green;"></span>	NEW PERVIOUS AREAS
<span style="display:inline-block; width:15px; border-bottom:1px dashed black;"></span>	LIMITS OF WORK

AREAS	
PRE-DEVELOPMENT PERVIOUS AREA	7,374 S.F.
POST-DEVELOPMENT PERVIOUS AREA	7,912 S.F.
NEW PERVIOUS AREA	538 S.F.
NEW IMPERVIOUS AREA	5,284 S.F.
REPAVED IMPERVIOUS AREA	3,555 S.F.
<b>TOTAL DISTURBED AREA</b>	<b>9,337 S.F.</b>
<b>TOTAL SITE AREA</b>	<b>23,139 S.F.</b>

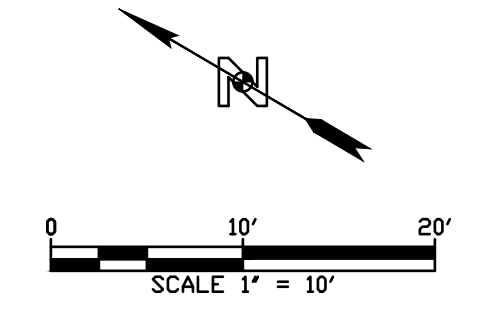

NO.	DATE	REVISION DESCRIPTION	BY	DATE

**DIGALERT**  
  
 DIAL TOLL FREE  
**811**  
 AT LEAST TWO DAYS  
 BEFORE YOU DIG  
 UNDERGROUND SERVICE ALERT OF SOUTHERN CALIFORNIA

**NOTICE TO CONTRACTOR:**

- THE LOCATIONS OF EXISTING UTILITY INSTALLATIONS AS SHOWN ON THIS PLAN ARE APPROXIMATE. THERE MAY BE OTHER UNDERGROUND UTILITY INSTALLATIONS WITHIN THE PROJECT AREA THAT ARE NOT SHOWN.
- N CONSULTING ASSUMES NO RESPONSIBILITY FOR DAMAGES, LIABILITY OR COSTS RESULTING FROM CHANGES OR ALTERATIONS MADE TO THIS PLAN WITHOUT THE EXPRESSED WRITTEN CONSENT OF N CONSULTING.

**SURVEYOR'S BENCHMARK**  
 THE BEARINGS AND DISTANCES ARE BASED ON THE CALIFORNIA COORDINATE SYSTEM OF 1983 (CCS83) ZONE II, RELATIVE TO THE NORTH AMERICAN DATUM OF 1983 (2017 20 EPOCH) AND WERE DETERMINED BY STATIC GPS TIES TO TWO CONTINUOUS GPS STATIONS (CGPS) REFERRED TO AS 1907 AND 1922. BEARINGS BETWEEN BOTH STATIONS BEING NORTH 45.4629° WEST BASED ON POSITIONS PUBLISHED IN THE CALIFORNIA SPATIAL REFERENCE CENTER.  
 ALL DISTANCES ARE GROUND, UNLESS OTHERWISE NOTED. TO OBTAIN GRID, MULTIPLE GROUND DISTANCE BY A COMBINED FACTOR OF 0.99974832.  
**BASIS OF BEARINGS**  
 BENCHMARK: C.I.B.E. ELEVATION: 159.909  
 DESCRIPTION: THIRD ST. AND 9" 31.2" BRASS DISK MARKED "CITY OF SANTA ROSA IN WELL MONUMENT, 30 FT. WID. CL. INTERSECTION. (COORDINATE MONUMENT G-516) 7/64

**N CONSULTING ENGINEERS**  
  
 17780 Fitch  
 Irvine, CA 92614  
 PHONE: 949.396.1161  
 www.nconsulteng.com  
 DEREK H. KARIMOTO DATE

ISSUE: GRADING 1ST SUBMITTAL  
 PROJECT ADDRESS: 1071 SANTA ROSA PLAZA, SANTA ROSA, CA 95401  
 CLIENT: SIMON PROPERTY GROUP, 225 WEST WASHINGTON ST, INDIANAPOLIS, IL 46204-3438

SITE: SANTA ROSA PLAZA			
TITLE: SITE AREAS			
DRAWN: D.M.	SCALE AT D: 1" = 10'	DATE: 2/7/2024	PROJECT NO: 22-007
CHECKED: F.L.	REV: ---	COUNT: 1 OF 1 SHEETS	SHEET: EXH103